

LECTURE NOTES

ON

**ENGINEERING MECHANICS
ACADEMIC YEAR 2021-22**

I B.Tech.–II SEMESTER (R20)

T KUMAR RAJU, Assistant Professor



DEPARTMENT OF HUMANITIES AND BASIC SCIENCES

**V S M COLLEGE OF ENGINEERING
RAMACHANDRAPURAM
E.G DISTRICT
533255**



JAWAHARLAL NEHRU TECHNOLOGICAL UNIVERSITY KAKINADA
KAKINADA – 533 003, Andhra Pradesh, India

DEPARTMENT OF MECHANICAL ENGINEERING

I Year - II Semester		L	T	P	C
		3	0	0	3
ENGINEERING MECHANICS					

Objectives: The students completing this course are expected to understand the concepts of forces and its resolution in different planes, resultant of force system, Forces acting on a body, their free body diagrams using graphical methods. They are required to understand the concepts of centre of gravity and moments of inertia and their application, Analysis of frames and trusses, different types of motion, friction and application of work - energy method.

UNIT – I

Objectives: The students are to be exposed to the concepts of force and friction, direction and its application.

Introduction to Engg. Mechanics – Basic Concepts.

Systems of Forces: Coplanar Concurrent Forces – Components in Space – Resultant – Moment of Force and its Application – Couples and Resultant of Force Systems.

Friction: Introduction, limiting friction and impending motion, coulomb's laws of dry friction, coefficient of friction, cone of friction

UNIT II

Objectives: The students are to be exposed to application of free body diagrams. Solution to problems using graphical methods and law of triangle of forces.

Equilibrium of Systems of Forces: Free Body Diagrams, Lami's Theorem, Equations of Equilibrium of Coplanar Systems, Graphical method for the equilibrium, Triangle law of forces, converse of the law of polygon of forces condition of equilibrium, Equations of Equilibrium for Spatial System of forces, Numerical examples on spatial system of forces using vector approach, Analysis of plane trusses.

UNIT – III

Objectives : The students are to be exposed to concepts of centre of gravity. The students are to be exposed to concepts of moment of inertia and polar moment of inertia including transfer methods and their applications.

Centroid: Centroids of simple figures (from basic principles) – Centroids of Composite Figures

Centre of Gravity: Centre of gravity of simple body (from basic principles), centre of gravity of composite bodies, Pappus theorems.

Area moments of Inertia: Definition – Polar Moment of Inertia, Transfer Theorem, Moments of Inertia of Composite Figures, Products of Inertia, Transfer Formula for Product of Inertia. **Mass Moment of Inertia:** Moment of Inertia of Masses, Transfer Formula for Mass Moments of Inertia, mass moment of inertia of composite bodies.

UNIT – IV

Objectives: The students are to be exposed to motion in straight line and in curvilinear paths, its velocity and acceleration computation and methods of representing plane motion.

Rectilinear and Curvilinear motion of a particle: Kinematics and Kinetics- Work Energy method and applications to particle motion- Impulse momentum method.



JAWAHARLAL NEHRU TECHNOLOGICAL UNIVERSITY KAKINADA
KAKINADA – 533 003, Andhra Pradesh, India

DEPARTMENT OF MECHANICAL ENGINEERING

UNIT – V

Objectives: The students are to be exposed to rigid motion kinematics and kinetics

Rigid body Motion: Kinematics and kinetics of translation, Rotation about fixed axis and plane motion, Work Energy method and Impulse momentum method.

TEXT BOOK:

1. Engg. Mechanics - S.Timoshenko & D.H.Young., 4th Edn - , Mc Graw Hill publications.

Course outcomes:

1. The student should be able to draw free body diagrams for FBDs for particles and rigid bodies in plane and space and problems to solve the unknown forces, orientations and geometric parameters.
2. He should be able to determine centroid for lines, areas and center of gravity for volumes and their composites.
3. He should be able to determine area and mass moment of inertia for composite sections
4. He should be able to analyze motion of particles and rigid bodies and apply the principles of motion, work energy and impulse – momentum.

VSM COLLEGE OF ENGINEERING
RAMACHANDRAPURUM-533255
DEPARTMENT OF ELECTRICAL AND ELECTRONICS ENGINEERING

Course Title	Year-Sem	Branch	Contact Periods/Week	Sections
ENGINEERING MECHANICS	2-1	MECHANICAL ENGINEERING / CIVIL ENGINEERING	6	-

COURSE OUTCOMES: Students are able to

1. The students are to be exposed to the concepts of force and friction, direction and its application.
2. The students are to be exposed to application of free body diagrams. Solution to problems using graphical methods and law of triangle of forces
3. The students are to be exposed to concepts of center of gravity. The students are to be exposed to concepts of moment of inertia and polar moment of inertia including transfer methods and their applications.
4. The students are to be exposed to motion in straight line and in curvilinear paths, its velocity and acceleration computation and methods of representing plane motion.
5. The students are to be exposed to rigid motion kinematics and kinetics.

Unit/item No.	Outcomes	Topic	Number of periods	Total periods	Book Reference	Delivery Method	
1	C01 To learn the principles of statics, able to find resultant & resolution of system of forces and resultant force.	UNIT – I Introduction to Engineering Mechanics – Basic Concepts			15	T1,T2, R20,R16	Chalk & Talk, Board
		1.1	Systems of Forces, Coplanar Concurrent Forces	2			
		1.2	Components in Space – Resultant	2			
		1.3	Moment of Force and its Application	2			
		1.4	Couples and Resultant of Force Systems	2			
		1.5	Friction: Introduction, limiting friction and impending motion	2			
		1.6	coulomb's laws of dry friction	2			
		1.7	coefficient of friction, cone of friction	2			
		1.8	Problems on above topics	1			
		UNIT- II Equilibrium of Systems of Forces			14		Chalk & Talk, Board
	C02 Explore the	2.1	Free Body Diagrams, , Lami's	4			

2	concepts of constraints, free body diagram and action-reaction		Theorem, Equations of Equilibrium of Coplanar Systems		T1,T2, R20,R16		
		2.2	Graphical method for the equilibrium, Triangle law of forces, converse of the law of polygon of forces condition of equilibrium,	4			
		2.3	Equations of Equilibrium for Spatial System of forces	2			
		2.4	Numerical examples on spatial system of forces using vector approach	2			
		2.5	Analysis of plane trusses	2			
3	CO3 Estimate the geometric parameters like centroid, center of gravity and moment of inertia and identify their application	UNIT – III Centroid			19	T1,T2, R20,R16	Chalk & Talk, Board
		3.1	Centroids of simple figures (from basic principles) – Centroids of Composite Figures	4			
		3.2	Centre of Gravity: Centre of gravity of simple body	3			
		3.3	Center of gravity of composite bodies, Pappus theorems.	2			
		3.4	Area moments of Inertia: Definition – Polar Moment of Inertia	2			
		3.5	Transfer Theorem, Moments of Inertia of Composite Figures	2			
		3.6	Products of Inertia, Transfer Formula for Product of Inertia	2			
		3.7	Mass Moment of Inertia: Moment of Inertia of Masses	2			
		3.8	Transfer Formula for Mass Moments of Inertia, mass moment of inertia of composite bodies.	2			
4	CO4 Learn the analysis of frames and trusses and know the importance of friction	UNIT – IV Rectilinear and Curvilinear motion of a particle			10	T1,T2, R20,R16	Chalk & Talk, Board
		4.1	Kinematics and Kinetics-Alembert's Principle,	4			
		4.2	Work Energy method and applications to particle motion	3			
		4.3	Impulse momentum method.	3			

5	C05 Able to determine solution to dynamic problems through equilibrium equations impulse moment and work energy method.	UNIT – V Rigid body Motion			10	T1,T2, R20,R16	Chalk & Talk, Board
		5.1	Kinematics and kinetics of translation	5			
		5.2	Rotation about fixed axis and plane motion	2			
		5.3	Work Energy method and Impulse momentum method	3			
			TOTAL	68			

LIST OF TEXT BOOKS AND AUTHORS

Text Book:

1. Engg. Mechanics - S.Timoshenko & D.H.Young., 4th Edn - , Mc Graw Hill publications.
2. Engineering Mechanics statics and dynamics – R.C.Hibbeler, 11th Edn – Pearson Publ.
3. Theory & Problems of engineering mechanics, statics & dynamics – E.W.Nelson, C.L.Best & W.G.McLean, 5th Edn – Schaum’s outline series - Mc Graw Hill Publ.

Reference Books:

1. Engineering Mechanics , statics – J.L.Meriam, 6th Edn – Wiley India Pvt Ltd.
2. Engineering Mechanics , dynamics – J.L.Meriam, 6th Edn – Wiley India Pvt Ltd.
3. Engineering Mechanics , statics and dynamics – I.H.Shames, – Pearson Publ.
4. Mechanics For Engineers , statics - F.P.Beer & E.R.Johnston – 5th Edn Mc Graw Hill Publ.
5. Mechanics For Engineers, dynamics - F.P.Beer & E.R.Johnston –5th Edn Mc Graw Hill Publ.
6. Engineering Mechanics , Ferdinand . L. Singer , Harper – Collins.
7. Engineering Mechanics statics and dynamics , A Nelson , Mc Graw Hill publications
8. Engineering Mechanics, Tayal. Umesh Publ.

Faculty Member

Head of the Department

PRINCIPAL

- بِسْمِ اللّٰهِ الرَّحْمٰنِ الرَّحِیْمِ -

ENGINEERING MECHANICS

General Principles :

Mechanics: Mechanics is a branch of physical sciences that is concerned with the state of rest or motion of bodies that are subjected to the action of forces.

In general, this subject can be subdivided into three branches: rigid body mechanics, deformable body mechanics, and fluid mechanics.

We will study only the rigid body mechanics.

Rigid body mechanics is divided into two areas: Statics and Dynamics.

"Statics" deals with the equilibrium of bodies that are either at rest or move with constant velocity, whereas "Dynamics" is concerned with the accelerated motion of bodies.

Fundamental Concepts:

Basic Quantities: There are four basic quantities in mechanics.

1. Length: Length is used to locate the position of a point and to describe the size of physical systems.
2. Time: Time is a succession of events. It is important in "Dynamics".
3. Mass: Mass is a measure of quantity of matter.
4. Force: Force is a push or pull exerted by one body on another.

Idealization: Models or idealizations are used to simplify application of the theory. There are three important idealizations:

- 1- Particle: A particle has a mass, but a size that can be neglected.

For example, earth can be modeled as a particle compared to its orbit.



Rigid body: A rigid body is a combination of a large number of particles in which all the particles remain at a fixed distance from one another, both before and after applying a load.

3. Concentrated force: A concentrated force represents the effect of a load which is assumed to act at a point on a body when the contact area is small compared with the overall size.

Newton's Three Laws of Motion:

Engineering Mechanics is formulated on the basis of Newton's three laws of motion.

First Law: a particle originally at rest, or moving in a straight line with constant velocity tends to remain in this state provided the particle is not subjected to an unbalanced force.

Second Law: a particle acted upon by an unbalanced force (F) experiences an acceleration (a) that has the same direction of the force and a magnitude that is proportional to the force.

mathematically: $F = m * a$

Third Law: For every action there is an equal and opposite reaction.

Newton's Law of Gravitational Attraction.

The gravitational attraction force between any two particles is:

$$F = G \frac{m_1 \cdot m_2}{r^2}$$

where:

F = force of gravitation between the two particles.

G = universal constant of gravitation

$$= 66.73 \times 10^{-12} \text{ m}^3 / \text{kg} \cdot \text{s}^2$$

m_1, m_2 = mass of each of the two bodies.

r = distance between the two particles.

Weight: The weight of a particle is the gravitational force between a particle and the earth.

By using the equation $F = G \frac{m_1 \cdot m_2}{r^2}$

$$W = G \frac{m \cdot M_e}{r^2}$$

M_e = mass of the earth.

m = mass of the particle.

r = distance between the particle and the center of the earth.

W = Weight of the particle.

$$\Rightarrow \boxed{W = m * g}$$

m (in kg) \Rightarrow W (in N)

g = gravitational acceleration.

$\approx 9.81 \text{ m/s}^2$ at sea level and latitude 45°
(standard location).

$\approx 32.17 \text{ ft/s}^2$

For example: ① if $m = 2 \text{ kg} \Rightarrow W = 2 * 9.81 = 19.62 \text{ N}$

② if $m = 300 \text{ g} \Rightarrow m = 0.3 \text{ kg} \Rightarrow W = 0.3 * 9.81 = 2.943 \text{ N}$

Units of Measurements :

A unit of measurement is a definite magnitude of a physical quantity.

There are two main measurement systems:

1. Metric System (International System SI):

This system is based on three main units, meter - kilogram - second (mks system).

SI is an abbreviation of French expression (Systeme International) in English (International System).

The common units in SI system are:

g, kg, ton, mm, m, N, kN, Kelvin, Celsius.

2. English System (British System) (or Imperial System) (or US customary System):

This system is based on foot - Pound - second

It is also called (FPS system).

The common units in British System are:

lb, slug, inch, ft, mile, Fahrenheit.

Prefixes: When a numerical quantity is either very large or very small, the units used to define its size may be modified by using a prefix.

The common prefixes are:

<u>Multiplication factor</u>	<u>Prefix</u>	<u>Symbol</u>
10^{12}	terra	T
10^9	giga	G
10^6	mega	M
10^3	kilo	k
10^2	hecto	h
10	deca	da
10^{-1}	deci	d
10^{-2}	centi	c
10^{-3}	milli	m
10^{-6}	micro	μ
10^{-9}	nano	n
10^{-12}	pico	p

Examples ① $5\,000\,000\text{ N} = 5000\text{ kN} = 5\text{ MN}$

② $0.003\text{ m} = 3 \times 10^{-3}\text{ m} = 3\text{ mm}$

③ $5\text{ kg} = 5 \times 10^3\text{ g} = 5000\text{ g}$

Common Unit Conversions:

Length:

$$1 \text{ m} = 3.28 \text{ ft}$$

$$1 \text{ ft} = 30.48 \text{ cm}$$

$$1 \text{ in} = 2.54 \text{ cm} = 25.4 \text{ mm}$$

$$1 \text{ mile} = 5280 \text{ ft} = 1609.34 \text{ m} = 1.60934 \text{ km} \approx 1.61 \text{ km}$$

$$\Rightarrow [1 \text{ mph (mile per hour)} \approx 1.61 \text{ km/h}]$$

$$1 \text{ yard} = 3 \text{ ft}$$

$$1 \text{ ft} = 12 \text{ in}$$

Mass and Weight:

$$1 \text{ lb} = 453.59 \text{ g}$$

(lb = Pound, from Roman word libra)

$$\Rightarrow 1 \text{ kg} = 2.205 \text{ lb}$$

$$1 \text{ lb} = 4.448 \text{ N}$$

$$1 \text{ stone} = 14 \text{ lb}$$

$$1 \text{ slug} = 32.17 \text{ lb} = 14.59 \text{ kg}$$

$$1 \text{ lb} = 16 \text{ ounce}$$

$$1 \text{ kg} = 9.81 \text{ N}$$

Temperature:

$$^{\circ}\text{F} = \frac{9}{5} ^{\circ}\text{C} + 32$$

$$\Rightarrow ^{\circ}\text{C} = \frac{5}{9} (^{\circ}\text{F} - 32)$$

$$\text{K} = ^{\circ}\text{C} + 273.15$$

$^{\circ}\text{F}$: Fahrenheit (British unit)

$^{\circ}\text{C}$: Celsius (SI units)

K : Kelvin (SI units)

$$\underline{\text{Volume:}} \quad 1 \text{ liter} = 1000 \text{ cm}^3, \quad 1 \text{ m}^3 = 1000 \text{ liter}$$

Examples for unit conversions :

① Convert 3 kN to kg.

$$1 \text{ kg} = 9.81 \text{ N} \Rightarrow 1 \text{ N} = \frac{1}{9.81} \text{ kg}$$

$$1 \text{ kN} = 10^3 \text{ N}$$

$$\Rightarrow 3 \text{ kN} = 3 \times 10^3 \text{ N} = \frac{3 \times 10^3}{9.81} \text{ kg} = 305.81 \text{ kg}$$

② Convert 20 lb to kg.

$$1 \text{ lb} = 453.59 \text{ g} = 0.45359 \text{ kg}$$

$$\Rightarrow 20 \text{ lb} = 20 \times 0.45359 \text{ kg} = 9.072 \text{ kg}$$

③ Convert 670 lb/ft³ to kg/m³.

$$1 \text{ lb} = 0.45359 \text{ kg}, \quad 1 \text{ ft} = 30.48 \text{ cm} = 0.3048 \text{ m}$$

$$\Rightarrow 670 \frac{\text{lb}}{\text{ft}^3} = 670 \times \frac{0.45359 \text{ kg}}{(0.3048 \text{ m})^3} = 10732.314 \text{ kg/m}^3$$

④ Convert 5000 in² to m².

$$1 \text{ in} = 2.54 \text{ cm} = \frac{2.54}{100} \text{ m} = 0.0254 \text{ m}$$

$$\Rightarrow 5000 \text{ in}^2 = 5000 (0.0254 \text{ m})^2 = 3.2258 \text{ m}^2$$

⑤ Convert 6 kN·m to lb·in.

$$1 \text{ lb} = 4.448 \text{ N} \Rightarrow 1 \text{ N} = \frac{1}{4.448} \text{ lb} \Rightarrow 1 \text{ kN} = \frac{10^3}{4.448} \text{ lb}$$

$$1 \text{ in} = 0.0254 \text{ m} \Rightarrow 1 \text{ m} = \frac{1}{0.0254} \text{ in}$$

$$\Rightarrow 6 \text{ kN}\cdot\text{m} = 6 \times \frac{10^3}{4.448} \text{ lb} \times \frac{1}{0.0254} \text{ in} = 53107.121 \text{ lb}\cdot\text{in}$$

Numerical Calculations :

It is important that the answers to any problem be reported with both justifiable accuracy and appropriate significant figures.

Dimensional Homogeneity : The terms of any equation used to describe a physical process must be dimensionally homogeneous.

For example : $5 \text{ m} + 70 \text{ cm}$
 $= 5 \text{ m} + 0.7 \text{ m} = 5.7 \text{ m}$
 or $= 500 \text{ cm} + 70 \text{ cm} = 570 \text{ cm}$

Significant Figures : The number of significant figures contained in any number determines the accuracy of the number.

For example, the number 3521 contains four significant figures.

35400 five significant figures.

$\Rightarrow 35.4 (10^3)$ three significant figures. (preferred)

$0.000421 \Rightarrow 0.421 (10^{-3})$ or $421 (10^{-6})$.

Rounding Off Numbers : For example if the rounding off is to three significant figures:

$3.2587 \Rightarrow 3.26$ rounding up since $8 > 5$.

$3.7421 \Rightarrow 3.74$ rounding down since $2 < 5$.

FORCE VECTORS

First we define the scalars and vectors:

Scalar: Is a quantity that characterized by a positive or negative number. For example: Mass, length.

Vector: Is a quantity that has both a magnitude and a direction. For example: Force, velocity.

A vector is represented graphically by an arrow. The length of arrow represents the magnitude, and the angle between the arrow line of action and a reference axis represents the direction.

From the figure shown:

The vector (**A**) has a magnitude of 3 units and a direction equals 35° measured counterclockwise from the reference line (horizontal here).

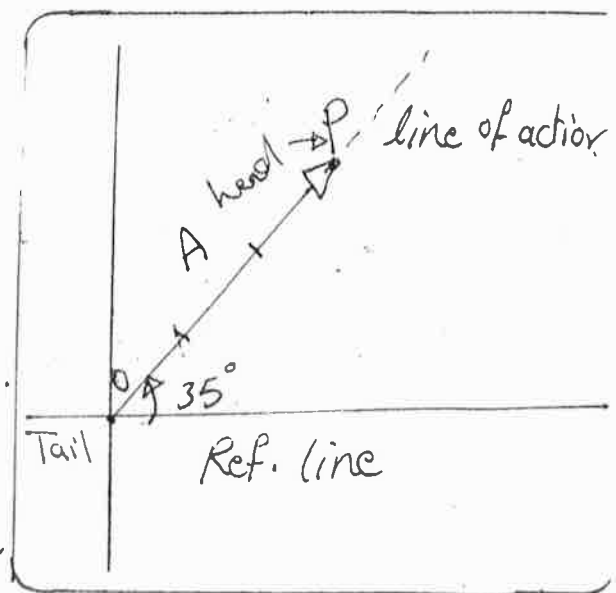

point (0) called tail and point (P) called tip (or head)

Vector operations:

(1) Multiplication of a vector by scalar:

For example:

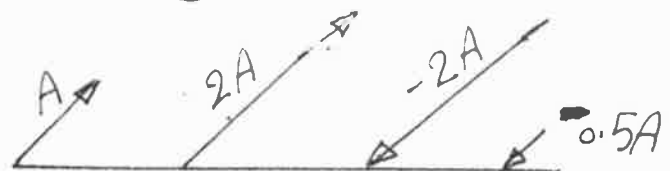

(11)

② Vector Addition:

If we have a two vectors (A) & (B) . These two vectors may be added to form a resultant vector $R = A + B$ by using the parallelogram

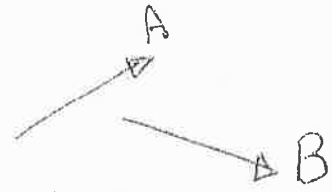

Law.

To do this, (A) & (B) are joined at their tails, parallel lines drawn from the head of each vector intersect at a common point to form a parallelogram which extends from the tail of (A) & (B) to the intersection point.

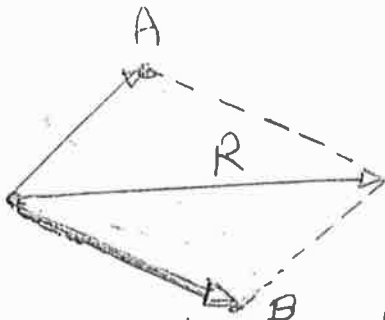

We can also add (B) to (A) using triangle construction which is a special case of parallelogram law. Connect the head of (A) to the tail of (B) . The resultant extends from the tail of (A) to the head of (B) .

or head of (B) to tail of (A) .

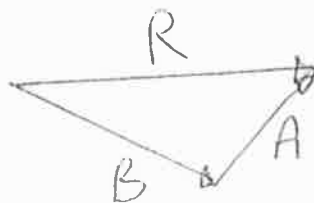

As a special case; if (A) & (B) are collinear (the both have the same line of action), (R) determined by scalar addition.

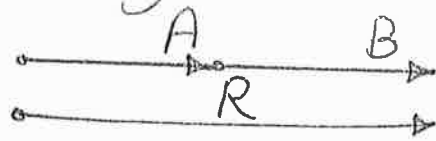

③ Vector subtraction:

The resultant difference between two vectors (A) & (B) may be expressed as $R' = A - B = A + (-B)$.

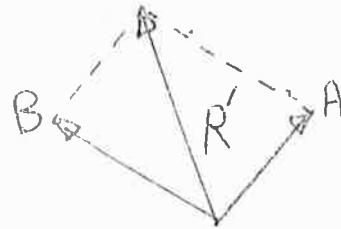
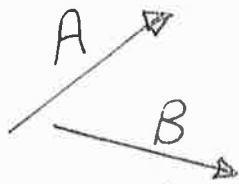

④ Resolution of a Vector:

A vector may be resolved into two components having known lines of action by using the parallelogram law.

For example: If (R) is to be resolved into component acting along the lines a & b. start from the head of R to draw a parallelogram.

Then, the component A & B extend from the tail of (R) to the intersection points.

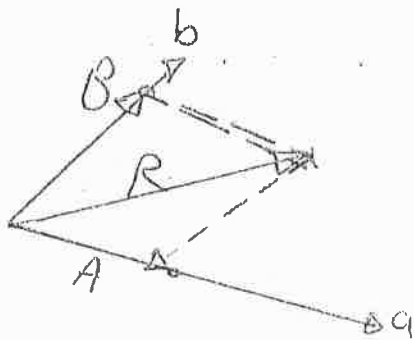

Finding a resultant force :-

By constructing parallelogram or triangle ;
 We can find the R by using cosine & sine law.

Addition of several forces:

Successive application of P.L.

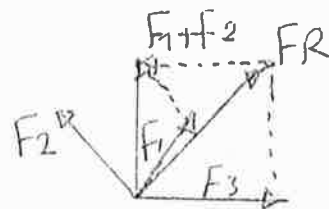

Vector - Addition of Forces:

A force is a vector quantity since it has magnitude, and direction. Therefore, the force addition will be according to the parallelogram law.

The sine law and the cosine Law:

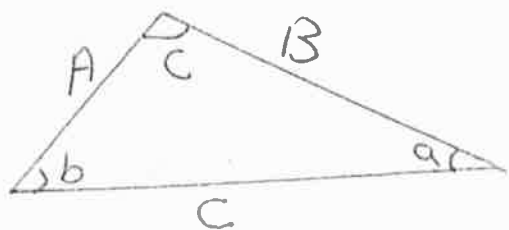

$$\text{Sine law} \Rightarrow \frac{A}{\sin a} = \frac{B}{\sin b} = \frac{C}{\sin c}$$

$$\text{Cosine law: } C = \sqrt{A^2 + B^2 - 2AB \cos c}$$

Examples:-

Ex1: Determine the magnitude of the resultant and the direction measured from the horizontal line.

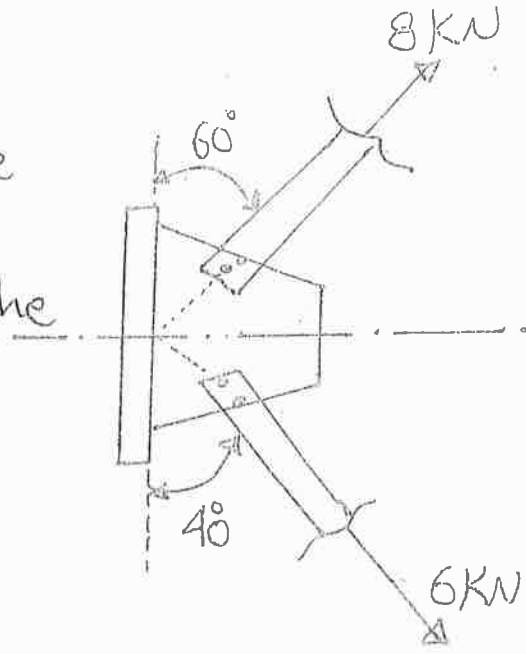

Sol. The parallelogram law of addition is shown below:

Use the cosine law:

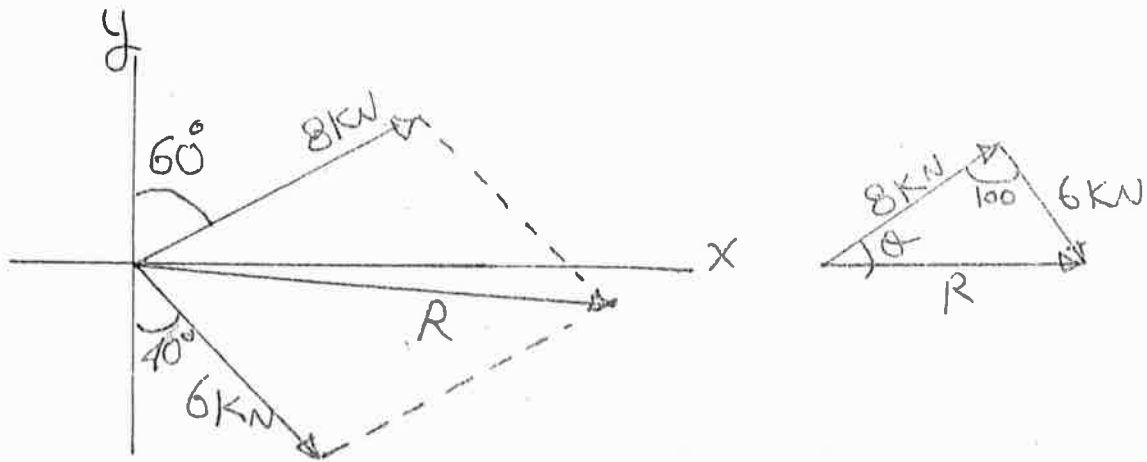

Use the cosine law

$$R = \sqrt{(8)^2 + (6)^2 - 2(8)(6) \cos 100^\circ} = 10.8 \text{ kN}$$

Use the sine law to find the angle θ :-

$$\frac{6}{\sin \theta} = \frac{10.8}{\sin 100} \implies \sin \theta = 0.5471 \implies \theta = 33.17^\circ$$

$$33.17 - 30 = 3.17^\circ$$



Ex.2: Determine the angle θ so that the resultant force is directed horizontally to the right. Also find the magnitude of the resultant.

Sol.

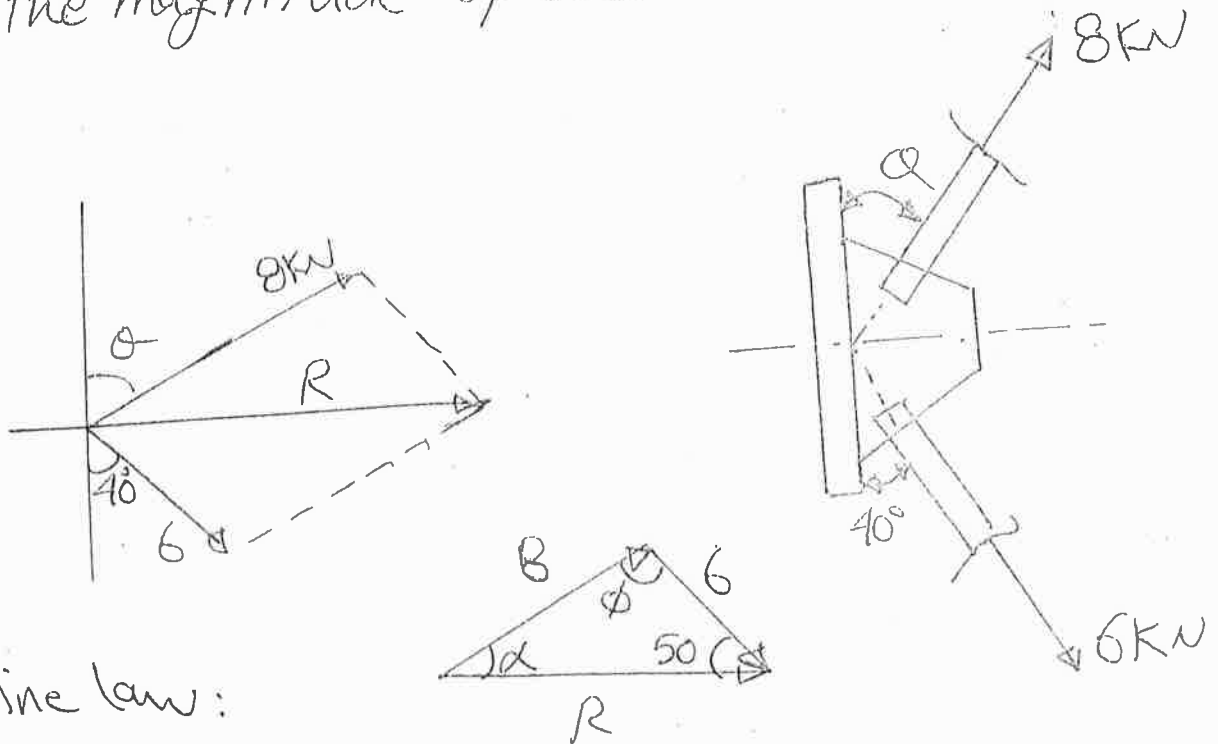

Use Sine law:

$$\frac{\sin \alpha}{6} = \frac{\sin 50}{8}$$

$$\sin \alpha = 0.5745 \quad \Rightarrow \quad \alpha = 35.06^\circ$$

$$\Rightarrow \theta = 54.94^\circ$$

From the triangle:

$$\phi = 180 - (35.06) - 50 = 94.94^\circ$$

Use Cosine law:

$$R = \sqrt{(8)^2 + (6)^2 - 2(8)(6) \cos 94.94^\circ}$$

$$= 10.4 \text{ kN}$$

Q3: Determine the magnitude of forces F_A and F_B acting on each chain in order to develop a resultant force of 600 N directed along the positive y-axis.

sol:

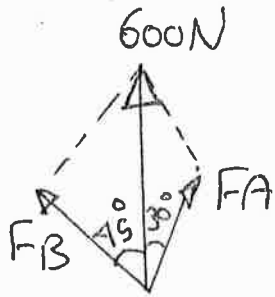

$$\angle = 180 - (45 + 30)$$

$$\angle = 105^\circ$$

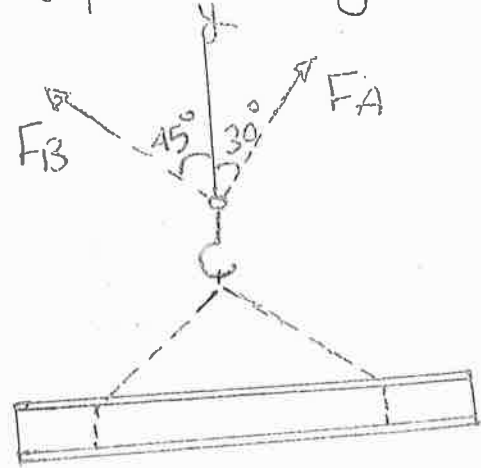
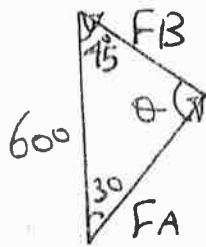

$$\frac{F_A}{\sin 45^\circ} = \frac{600}{\sin 105^\circ}$$

$$F_A = 439.23\text{ N}$$

$$\frac{F_B}{\sin 30^\circ} = \frac{600}{\sin 105^\circ}$$

$$F_B = 310.58\text{ N}$$

Ex 11: For the frame shown Determine the angle θ so that the horizontal component F_{AC} has a magnitude of 400 N, Also Find F_{AB}

Sol.

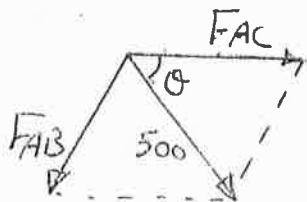

\Rightarrow

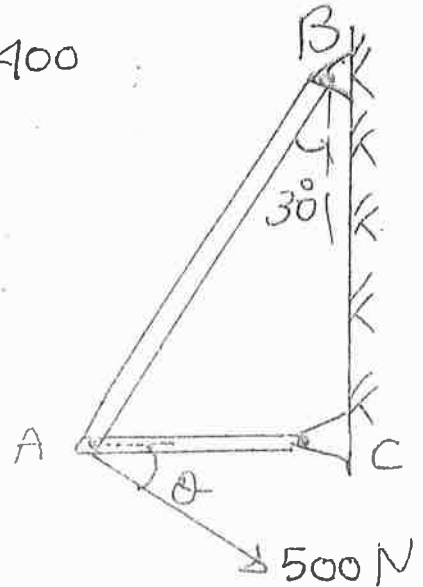
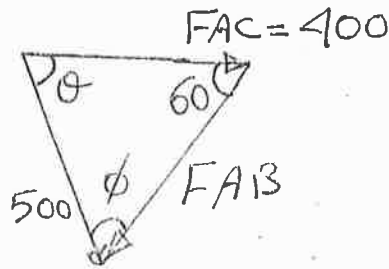

$$\frac{400}{\sin \phi} = \frac{500}{\sin 60^\circ}$$

$$\sin \phi = 0.6928$$

$$\therefore \phi = 43.85^\circ$$

$$\theta = 180^\circ - (60^\circ + 43.85^\circ) = 76.15^\circ$$

$$\frac{F_{AB}}{\sin 76.15} = \frac{500}{\sin 60} \Rightarrow F_{AB} = 560.56 \text{ N}$$

$$\text{or } F_{AB} = \sqrt{(500)^2 + (400)^2 - 2(500)(400)\cos 76.15}$$

$$F_{AB} = 560.58 \text{ N}$$

Ex 5: Resolve the 50 lb force into components acting along @ x & y axes (b) x & y axes

sol:

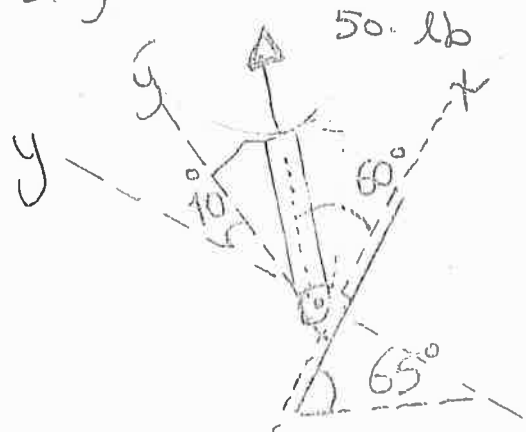
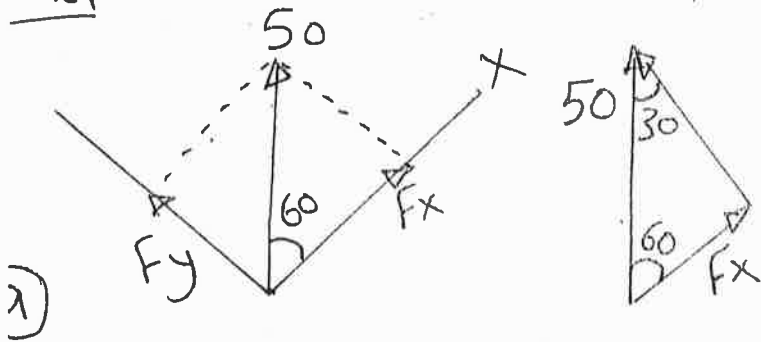

$$\frac{50}{\sin 90} = \frac{F_x}{\sin 30} \Rightarrow F_x = 50 \sin 30^\circ$$

$$F_x = 25 \text{ lb}$$

$$\frac{50}{\sin 90} = \frac{F_y}{\sin 60} \Rightarrow F_y = 50 \sin 60^\circ$$

$$F_y = 43.3 \text{ lb}$$

or $F_x = 50 \cos 60^\circ = 25$ & $F_y = 50 \sin 60^\circ = 43.3 \text{ lb}$

(b)

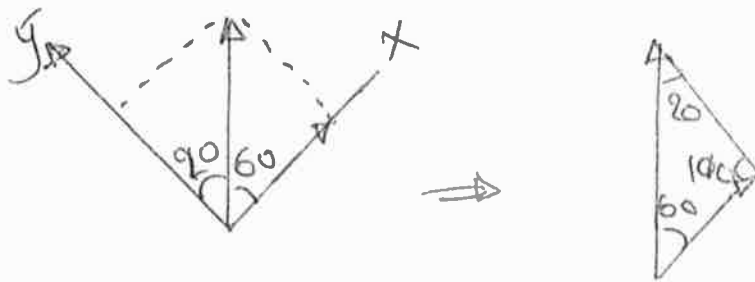

$$\frac{F_x}{\sin 20} = \frac{50}{\sin 100} \Rightarrow F_x = 17.36$$

$$\frac{F_y}{\sin 60} = \frac{50}{\sin 100} \Rightarrow F_y = 43.96$$

Ex 6: Determine the magnitude and the direction of the resultant force from the +ve x-axis.

Sol:

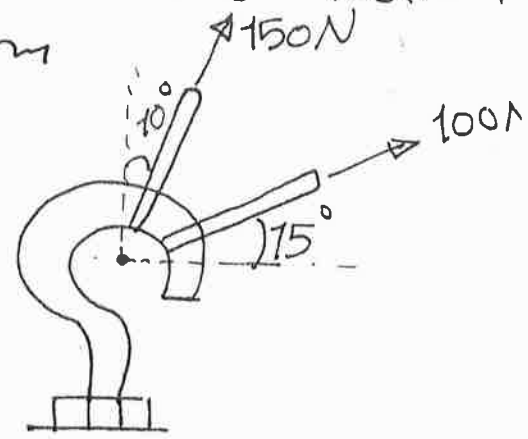
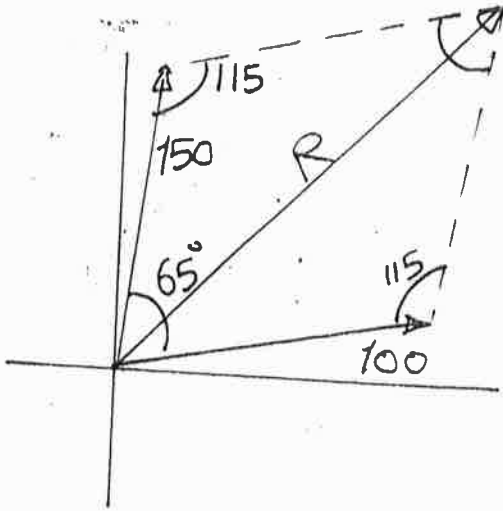

$$R = \sqrt{(100)^2 + (150)^2 - 2(100)(150) \cos 115}$$

$$= 212.6 \text{ N}$$

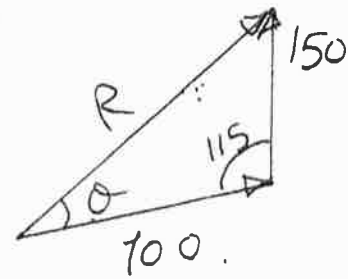

$$\frac{150}{\sin \theta} = \frac{212.6}{\sin 115}$$

$$\theta = 39.8^\circ$$

direction of Resultant with the horizontal

$$= 39.8 + 15$$

$$= 54.8^\circ$$

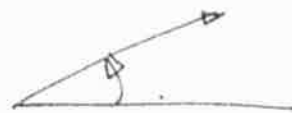

Resolving a Force into Rectangular Components:

When a force is resolved into two perpendicular axes, the components are called rectangular components.

We can represent these components by using either scalar notation or Cartesian vector notation.

1. Scalar Notation:

By using trigonometry:

$$\cos \theta = \frac{F_x}{F} \Rightarrow F_x = F \cos \theta$$

$$\sin \theta = \frac{F_y}{F} \Rightarrow F_y = F \sin \theta$$

Notice that the same results are obtained if we apply the sine law:

$$\frac{F}{\sin 90} = \frac{F_y}{\sin \theta} \Rightarrow F_y = F \sin \theta \quad [\text{since } \sin 90 = 1]$$

$$\text{Also } \frac{F}{\sin 90} = \frac{F_x}{\sin (90 - \theta)} \Rightarrow F_x = F \sin (90 - \theta) = F \cos \theta$$

If the force F is defined by a slope instead of the angle θ , then by using the triangles similarity:

$$\frac{F_x}{F} = \frac{a}{c} \Rightarrow F_x = F \left(\frac{a}{c} \right)$$

$$\frac{F_y}{F} = \frac{b}{c} \Rightarrow F_y = F \left(\frac{b}{c} \right)$$

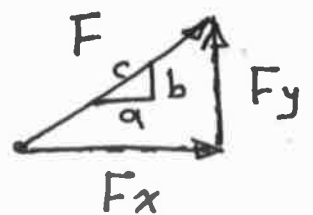
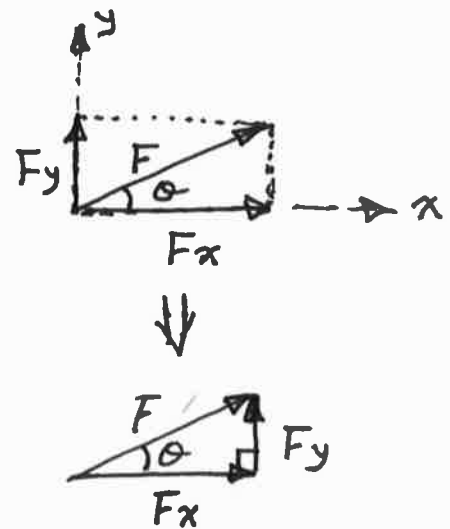

2. Cartesian Vector Notation:

It is also possible to represent the x and y components of a force in terms of Cartesian unit vectors i and j .

The unit vectors i & j are dimensionless and used to designate the directions of the components.

We can express the force F in Cartesian vectors as:

$$\boxed{\vec{F} = F_x i + F_y j}$$

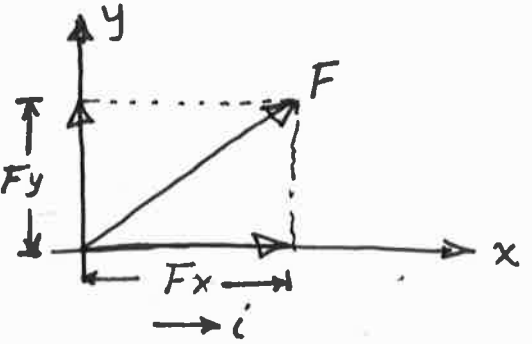

F_x & F_y are magnitudes (always positive), whereas i & j are unit vectors (positive or negative).

Coplanar Force Resultants:

We can use either of the two methods (scalar notation and Cartesian vector notation) to find the resultant of several coplanar forces.

By scalar notation method:

$$\rightarrow F_{Rx} = F_{1x} + F_{2x} - F_{3x} = \Sigma F_x$$

$$\uparrow F_{Ry} = F_{1y} - F_{2y} + F_{3y} = \Sigma F_y$$

$$F_R = \sqrt{(F_{Rx})^2 + (F_{Ry})^2}$$

$$\theta = \tan^{-1} \left| \frac{F_{Ry}}{F_{Rx}} \right|$$

F_{Rx} & F_{Ry} : Resultants in x & y directions.

F_R : Resultant, θ : direction of F_R

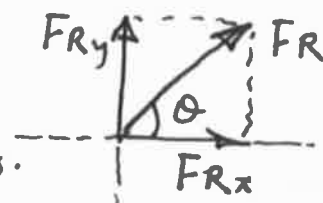
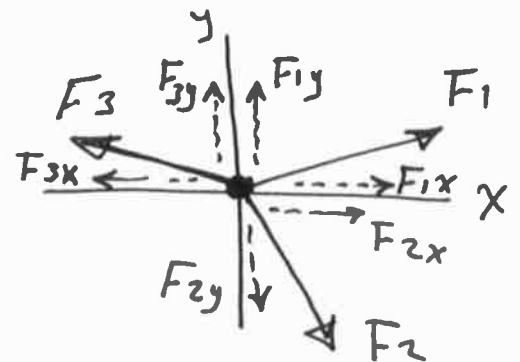

By Cartesian vector notation method:

$$\vec{F}_1 = F_{1x} i + F_{1y} j$$

$$\vec{F}_2 = F_{2x} i - F_{2y} j$$

$$\vec{F}_3 = -F_{3x} i + F_{3y} j$$

$$\vec{F}_R = \vec{F}_1 + \vec{F}_2 + \vec{F}_3$$

$$= F_{1x} i + F_{1y} j + F_{2x} i - F_{2y} j - F_{3x} i + F_{3y} j$$

$$= (F_{1x} + F_{2x} - F_{3x}) i + (F_{1y} - F_{2y} + F_{3y}) j$$

$$= (F_{Rx}) i + (F_{Ry}) j$$

Also the magnitude and the direction of F_R can be determined in the same manner as in scalar notation method.

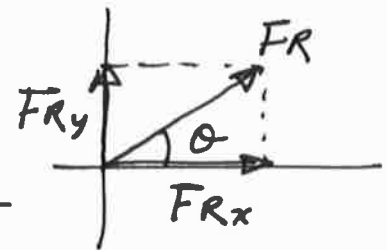
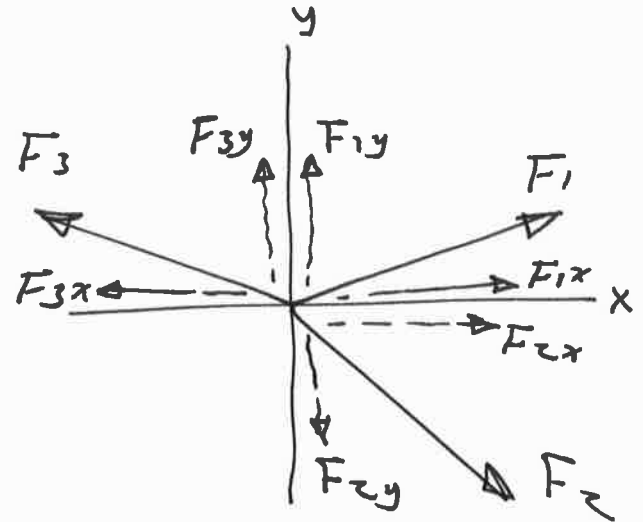

Briefly:

It is easier to find the resultant of coplanar forces by resolving each force into rectangular components, adding the components in each direction, and finally finding the resultant by using the Pythagorean theorem (if the scalar notation is used) and/or by vector addition (if the Cartesian vector notation is used).

Examples :

Ex.1 : Determine the x & y components for the 100 N - force.

sd.

$$\begin{aligned} \rightarrow F_x &= F \cos 30 \\ &= 100 \cos 30 = 86.60 \text{ N} \rightarrow \end{aligned}$$

$$\begin{aligned} \uparrow F_y &= F \sin 30 \\ &= -100 \sin 30 = -50 = 50 \text{ N} \downarrow \end{aligned}$$

the negative sign of the F_y indicates that F_y is directed in the opposite direction of the y.

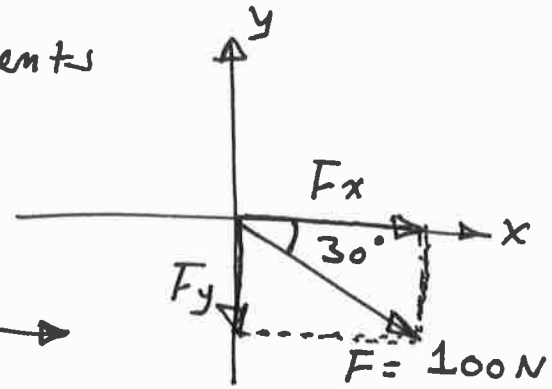

Ex.2 : Determine the x & y components for the 200 N - force.

sd.

$$\begin{aligned} \rightarrow F_x &= -200 \sin 60 \\ &= -173.2 = 173.2 \text{ N} \leftarrow \end{aligned}$$

$$\uparrow F_y = 200 \cos 60 = 100 \text{ N} \uparrow$$

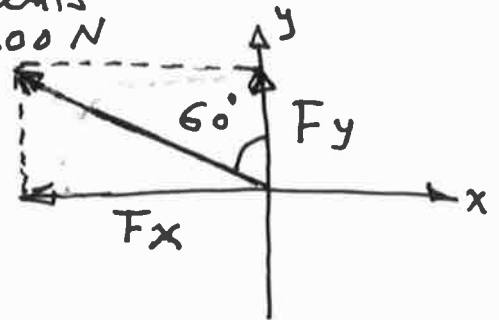

Ex.3 : Determine the x & y components for the 800 lb - force.

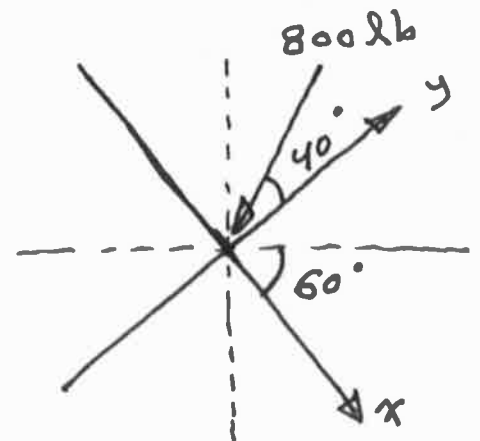
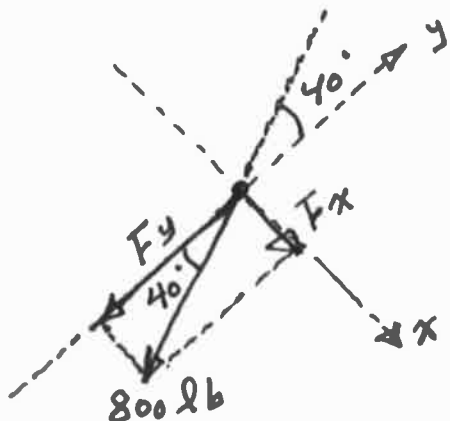

$$\searrow F_x = 800 \sin 40 = 514.23 \text{ lb} \searrow$$

$$\nearrow F_y = -800 \cos 40 = -612.83 = 612.83 \text{ lb} \nearrow$$

Ex.4: Determine the magnitude and the direction of the resultant force. Use the scalar notation and the Cartesian vector notation methods.

Sol.

① Scalar Notation:

$$\rightarrow F_{Rx} = \sum F_x = F_{x1} + F_{x2} + F_{x3}$$

$$= 850\left(\frac{4}{5}\right) - 625 \sin 30 - 750 \sin 45$$

$$= -162.83$$

$$= 162.83 \text{ N } \leftarrow$$

$$F_3 = 750 \text{ N}$$

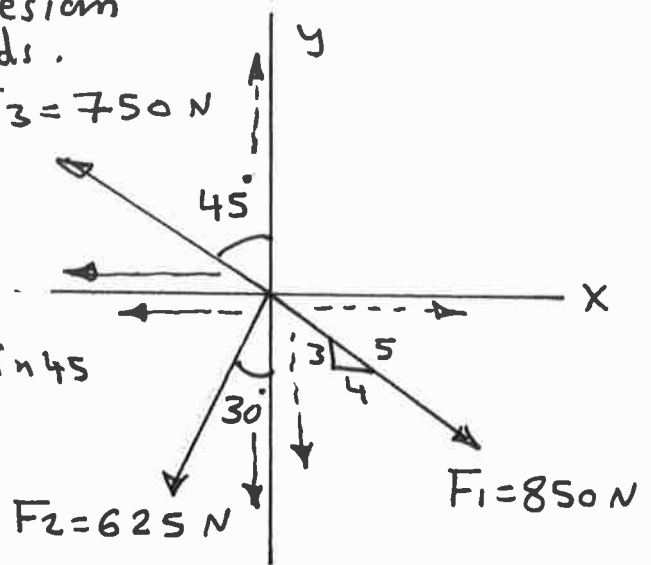

$$\uparrow F_{Ry} = \sum F_y = F_{y1} + F_{y2} + F_{y3}$$

$$= -850\left(\frac{3}{5}\right) - 625 \cos 30 + 750 \cos 45 = -520.93$$

$$= 520.93 \text{ N } \downarrow$$

$$F_R = \sqrt{(F_{Rx})^2 + (F_{Ry})^2}$$

$$= \sqrt{(162.83)^2 + (520.93)^2} = 545.78 \text{ N}$$

$$\theta = \tan^{-1} \frac{520.93}{162.83} = 72.64^\circ$$

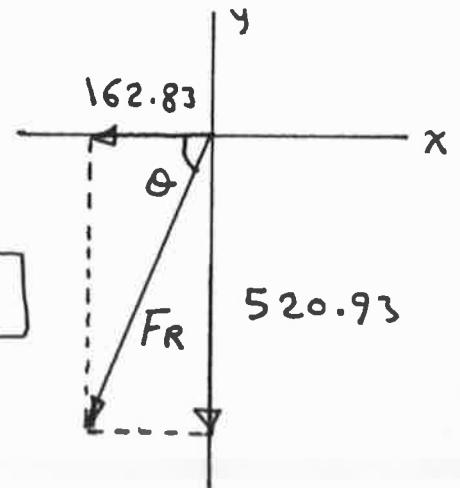

② Cartesian Vector Notation:

$$\vec{F}_R = \vec{F}_1 + \vec{F}_2 + \vec{F}_3$$

$$= \left(850\left(\frac{4}{5}\right) i - 850\left(\frac{3}{5}\right) j\right) + (-625 \sin 30 i - 625 \cos 30 j)$$

$$+ (-750 \sin 45 i + 750 \cos 45 j)$$

$$\Rightarrow \vec{F}_R = (-162.83 i - 520.93 j) \text{ N}$$

The magnitude and the direction of F_R are determined in the same manner as in the scalar notation.

Ex. 5: Determine the magnitude and the direction (or orientation), measured clockwise from the positive x-axis, of the resultant force for the three forces acting on the bracket.

Sol. Method I (By Scalar notation):

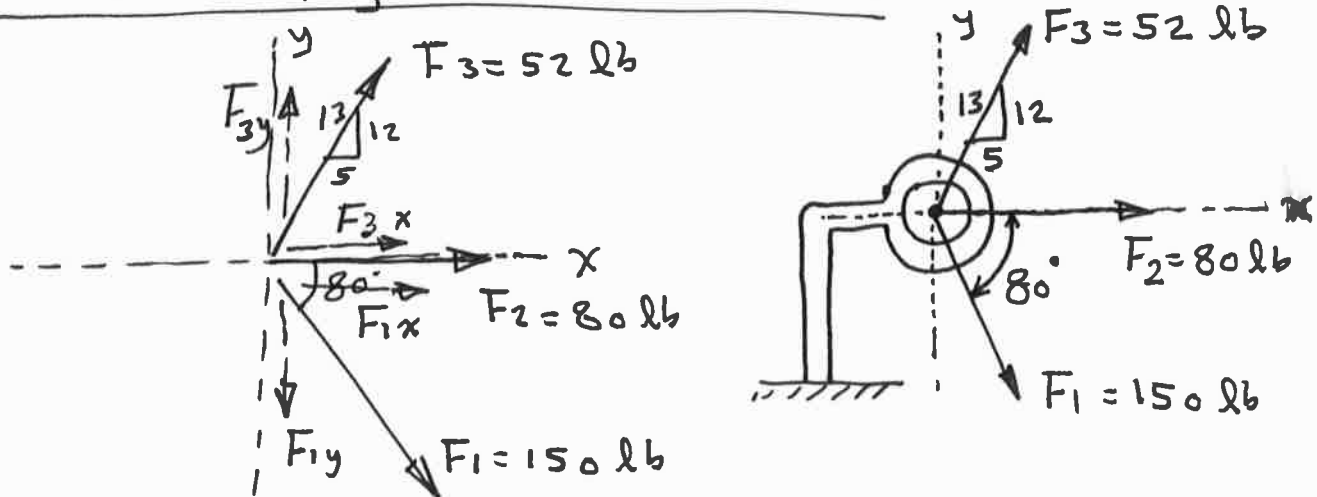

$$\begin{aligned} \rightarrow F_{Rx} &= \sum F_x = F_{1x} + F_{2x} + F_{3x} \\ &= 150 \cos 80 + 80 + 52 \left(\frac{5}{13} \right) = 126.05 \text{ lb} \rightarrow \end{aligned}$$

$$\begin{aligned} \uparrow F_{Ry} &= \sum F_y = F_{1y} + F_{2y} + F_{3y} \\ &= -150 \sin 80 + 0 + 52 \left(\frac{12}{13} \right) = -99.72 = 99.72 \text{ N} \downarrow \end{aligned}$$

$$F_R = \sqrt{(126.05)^2 + (99.72)^2} = \boxed{160.72 \text{ lb}}$$

$$\theta = \tan^{-1} \frac{99.72}{126.05} = \boxed{38.34^\circ}$$

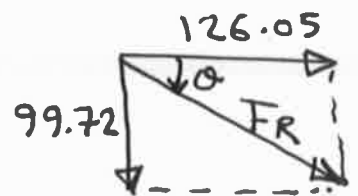

Method II (By Cartesian vector notation):

$$\begin{aligned} \vec{F}_R &= \vec{F}_1 + \vec{F}_2 + \vec{F}_3 \\ &= (150 \cos 80 \mathbf{i} - 150 \sin 80 \mathbf{j}) + (80 \mathbf{i} + 0 \mathbf{j}) + \left(52 \left(\frac{5}{13} \right) \mathbf{i} \right. \\ &\quad \left. + 52 \left(\frac{12}{13} \right) \mathbf{j} \right) = (126.05 \mathbf{i} - 99.72 \mathbf{j}) \end{aligned}$$

The magnitude and the direction of F_R as Method I.

Ex6: Determine the magnitude and the direction θ of the force F_1 so that the resultant force is directed vertically upward and has a magnitude of 800 N.

Sol.

$$\rightarrow F_{Rx} = \sum F_x$$

$$0 = F_1 \sin \theta + 400 \cos 30 - 600 \left(\frac{4}{5}\right)$$

$$\Rightarrow F_1 \sin \theta = 133.58 \quad \text{--- ①}$$

$$\uparrow F_{Ry} = \sum F_y$$

$$800 = F_1 \cos \theta + 400 \sin 30 + 600 \left(\frac{3}{5}\right)$$

$$\Rightarrow F_1 \cos \theta = 240 \quad \text{--- ②}$$

Divide eq. ① by ② $\Rightarrow \frac{F_1 \sin \theta}{F_1 \cos \theta} = \frac{133.58}{240}$

$$\Rightarrow \tan \theta = 0.5565 \Rightarrow \theta = 29.1^\circ$$

substitute into ① $\Rightarrow F_1 \sin 29.1 = 133.58 \Rightarrow F_1 = 274.66 \text{ N}$

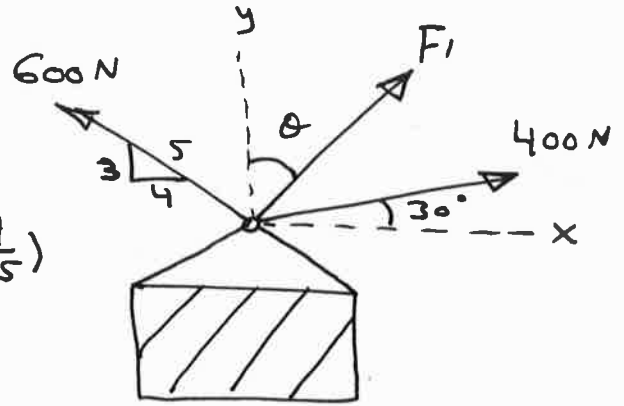

Ex.7: Determine the x & y components of each force acting on the gusset plate of the truss. Show that the resultant force is zero.

Sol. $F_{x1} = -200 = 200 \text{ lb}$ ↗

$$F_{y1} = 0$$

$$F_{x2} = 400 \left(\frac{4}{5}\right) = 320 \text{ lb}$$
 ↙

$$F_{y2} = -400 \left(\frac{3}{5}\right) = -240 = 240 \text{ lb}$$
 ↗

$$F_{x3} = 300 \left(\frac{3}{5}\right) = 180 \text{ lb}$$
 ↘

$$F_{y3} = 300 \left(\frac{4}{5}\right) = 240 \text{ lb}$$
 ↘

$$F_{x4} = -300 = 300 \text{ lb}$$
 ↗

$$F_{y4} = 0$$

$$F_{Rx} = -200 + 320 + 180 - 300 = 0, \quad F_{Ry} = 0 - 240 + 240 + 0 = 0$$

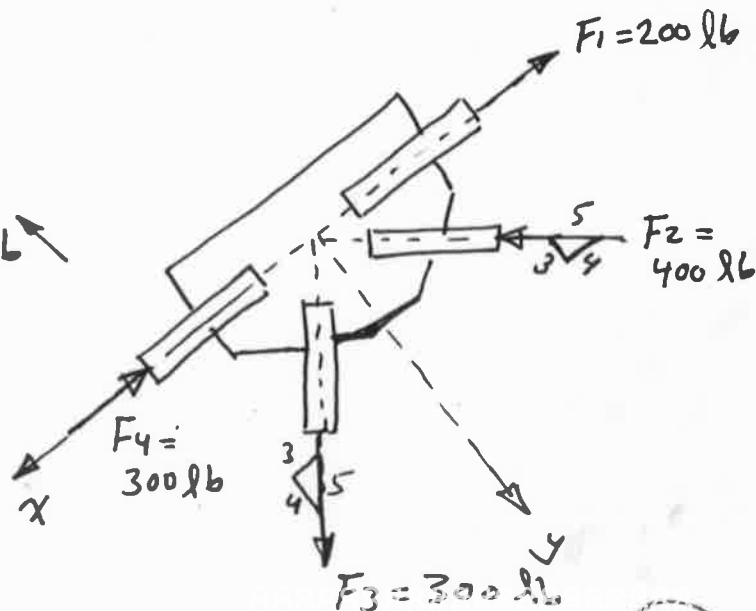

Forces in Three Dimensions :

The problems of forces in three dimensions are greatly simplified if the forces are represented in Cartesian vector form.

Right - Handed Coordinate System :

We will use the right hand rule to develop the theory of vector algebra.

In this rule, the thumb of the right hand points in the +ve z-axis when the fingers are curled about this axis and directed from the +ve x-axis to the +ve y-axis.

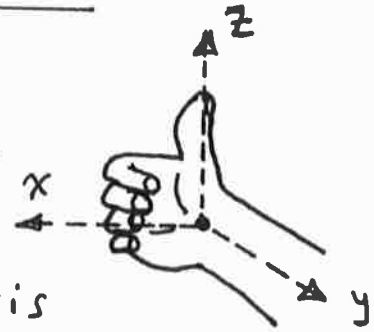

Rectangular Components of a Vector :

A vector A may have one, two, or three rectangular components along the x, y, z axes, depending on how the vector is oriented relative to the axes.

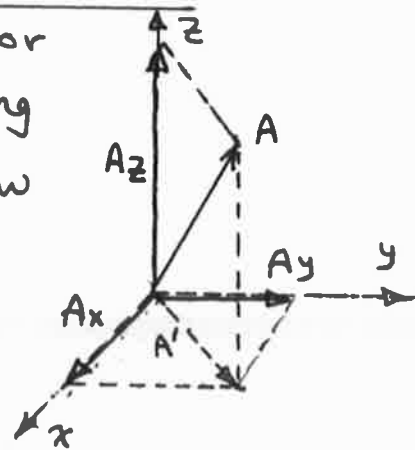

From the figure:

$$\vec{A} = \vec{A}' + \vec{A}_z \quad (\text{vector addition})$$

$$\text{but } \vec{A}' = \vec{A}_x + \vec{A}_y \implies \boxed{\vec{A} = \vec{A}_x + \vec{A}_y + \vec{A}_z}$$

The magnitude of the vector \vec{A} is determined by using the Pythagorean theorem: $A = \sqrt{(A')^2 + (A_z)^2}$, but $(A')^2 = (A_x)^2 + (A_y)^2$

$$\implies \boxed{A = \sqrt{(A_x)^2 + (A_y)^2 + (A_z)^2}}$$

Cartesian Unit Vectors :

In three dimensions the Cartesian unit vectors i, j, k are used to designate the directions of x, y, z axes respectively.

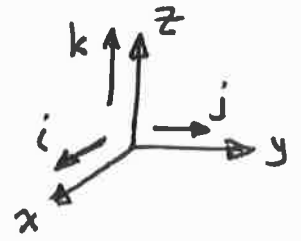

Cartesian Vector Representation :

The representation of a vector \vec{A} in Cartesian vector form is:

$$\vec{A} = A_x i + A_y j + A_z k$$

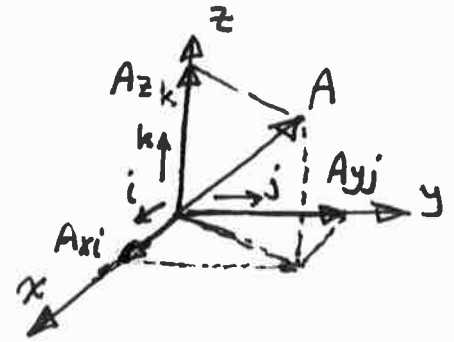

Separating the magnitude and the direction of each component vector will simplify the operations of vector algebra, particularly in three dimensions.

Direction of a Cartesian Vector :

We will define the direction of a vector A by the angles $\alpha, \beta,$ and γ , measured between the tail of A and the +ve x, y, z axes provided they are located at the tail of A .

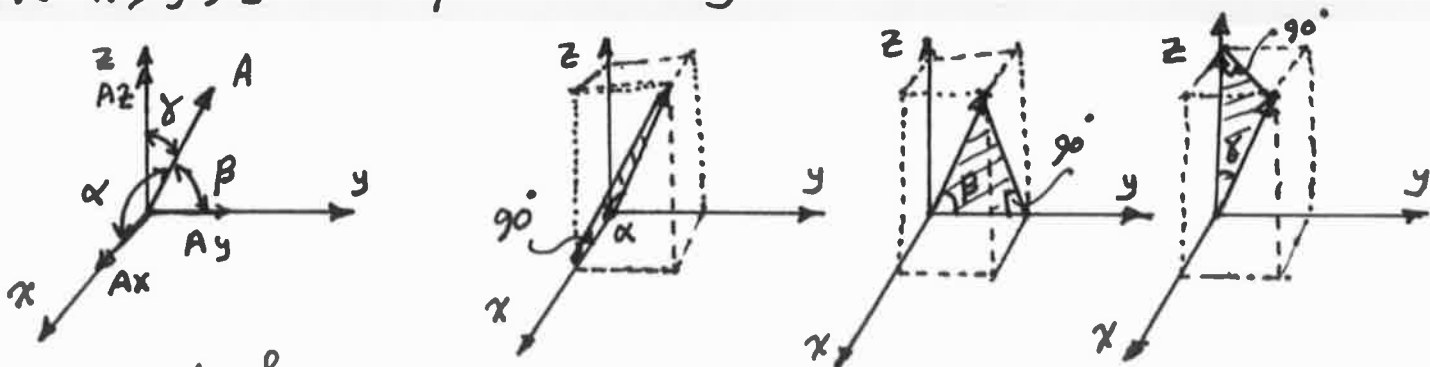

From the figures:

$$\cos \alpha = \frac{A_x}{A}, \quad \cos \beta = \frac{A_y}{A}, \quad \cos \gamma = \frac{A_z}{A}$$

Then the angles α, β, γ can be determined from the inverse cosines

An easy way of obtaining the angles α , β , and γ as follows:

We have $\vec{A} = A_x \hat{i} + A_y \hat{j} + A_z \hat{k}$

$$\Rightarrow A = \sqrt{A_x^2 + A_y^2 + A_z^2} \quad \text{--- ①}$$

Divide \vec{A} by $A \Rightarrow \frac{\vec{A}}{A} = \frac{A_x}{A} \hat{i} + \frac{A_y}{A} \hat{j} + \frac{A_z}{A} \hat{k}$

if $\vec{u}_A = \frac{\vec{A}}{A}$ is a unit vector of A ,

we have $\frac{A_x}{A} = \cos \alpha$, $\frac{A_y}{A} = \cos \beta$, $\frac{A_z}{A} = \cos \gamma$

$$\Rightarrow \vec{u}_A = \cos \alpha \hat{i} + \cos \beta \hat{j} + \cos \gamma \hat{k}$$

From eq. ①: $A^2 = A^2 \cos^2 \alpha + A^2 \cos^2 \beta + A^2 \cos^2 \gamma$

Divide by A^2 : $\Rightarrow \boxed{\cos^2 \alpha + \cos^2 \beta + \cos^2 \gamma = 1}$

Notice that the vector \vec{A} can be expressed as:

$$\boxed{\vec{A} = A \cos \alpha \hat{i} + A \cos \beta \hat{j} + A \cos \gamma \hat{k}} \quad \text{[from } \vec{A} = A_x \hat{i} + A_y \hat{j} + A_z \hat{k}]$$

Sometimes, the direction of the vector \vec{A} can be specified by two angles θ & ϕ as follows:

$$\left. \begin{array}{l} A_z = A \cos \phi \\ A' = A \sin \phi \end{array} \right\} \text{from upper shaded triangle}$$

from the lower shaded triangle:

$$A_x = A' \cos \theta = A \sin \phi \cos \theta$$

$$A_y = A' \sin \theta = A \sin \phi \sin \theta$$

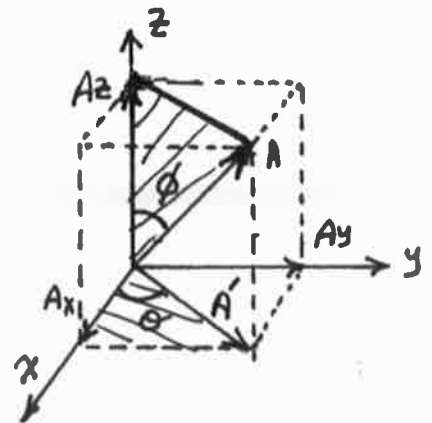

$$\Rightarrow \boxed{\vec{A} = A \sin \phi \cos \theta \hat{i} + A \sin \phi \sin \theta \hat{j} + A \cos \phi \hat{k}}$$

Addition of Cartesian Vectors in 3D:

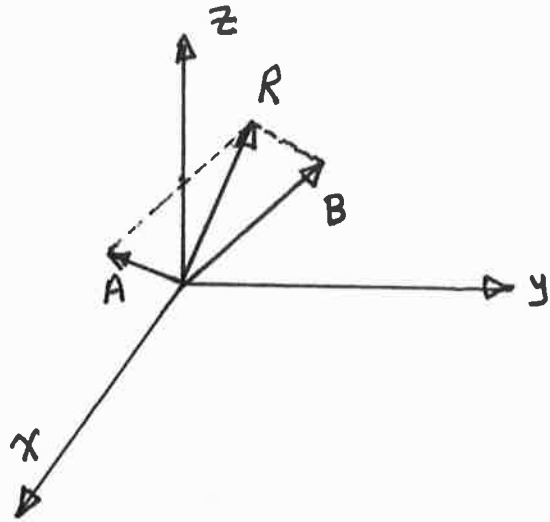

The addition (or subtraction) of two or more vectors are greatly simplified if the vectors are expressed in terms of their Cartesian components.

We have $\vec{A} = A_x i + A_y j + A_z k$

and $\vec{B} = B_x i + B_y j + B_z k$

The resultant $\vec{R} = \vec{A} + \vec{B}$

$$\Rightarrow \vec{R} = (A_x + B_x) i + (A_y + B_y) j + (A_z + B_z) k$$

For several concurrent forces, the resultant \vec{R} is:

$$\boxed{\vec{R} = \sum F_x i + \sum F_y j + \sum F_z k}$$

general equation
for two or more
concurrent forces.

Here $\sum F_x$, $\sum F_y$, and $\sum F_z$ represent the algebraic sums of the respective x , y , z or i , j , k components of each force in the system.

Brief:

$$\vec{A} = \vec{A}_x + \vec{A}_y + \vec{A}_z$$

vector addition

$$\vec{A} = A_x \hat{i} + A_y \hat{j} + A_z \hat{k}$$

vector expression
in Cartesian vectors.

$$A = \sqrt{(A_x)^2 + (A_y)^2 + (A_z)^2}$$

the magnitude of the
vector

$$\cos \alpha = \frac{A_x}{A}, \quad \cos \beta = \frac{A_y}{A}, \quad \cos \gamma = \frac{A_z}{A}$$

The direction angles of the vector.

$$\cos^2 \alpha + \cos^2 \beta + \cos^2 \gamma = 1$$

relation between
the direction angles.

$$\vec{A} = A \cos \alpha \hat{i} + A \cos \beta \hat{j} + A \cos \gamma \hat{k}$$

vector
expression in
terms of angles.

$$\vec{A} = A \sin \phi \cos \theta \hat{i} + A \sin \phi \sin \theta \hat{j} + A \cos \phi \hat{k}$$

vector expression in terms of two angles.

Examples:Ex.1: Express the force F as a Cartesian vector.Sol.

$$\cos^2 \alpha + \cos^2 \beta + \cos^2 \gamma = 1$$

$$\cos^2 \alpha + \cos^2 60 + \cos^2 45 = 1$$

$$\Rightarrow \cos \alpha = \sqrt{1 - (0.5)^2 - (0.707)^2}$$

$$= \pm 0.5$$

$$\Rightarrow \alpha = \cos^{-1}(+0.5) = 60^\circ$$

$$\text{or } \alpha = \cos^{-1}(-0.5) = 120^\circ$$

By inspection $\Rightarrow \alpha = 60^\circ$.

$$\Rightarrow \vec{F} = F \cos \alpha \mathbf{i} + F \cos \beta \mathbf{j} + F \cos \gamma \mathbf{k}$$

$$= (200 \cos 60) \mathbf{i} + (200 \cos 60) \mathbf{j} + (200 \cos 45) \mathbf{k}$$

$$= \{100 \mathbf{i} + 100 \mathbf{j} + 141.4 \mathbf{k}\} \text{ N}$$

Show that the magnitude of $F = 200 \text{ N}$.

$$F = \sqrt{F_x^2 + F_y^2 + F_z^2}$$

$$= \sqrt{100^2 + 100^2 + 141.4^2}$$

$$= 200 \text{ N} \quad \underline{\text{o.k.}}$$

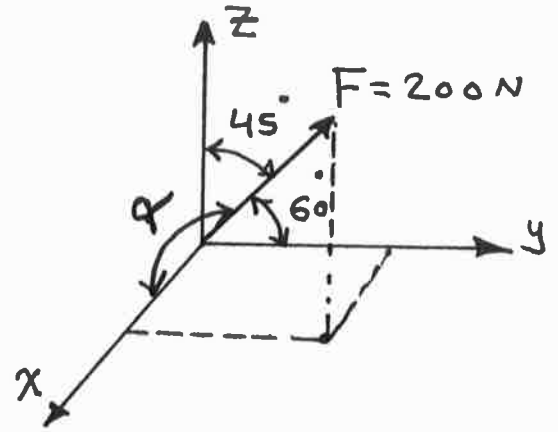

Ex.2 : Determine the magnitude and the direction angles of the resultant force acting on the ring.

Sol.

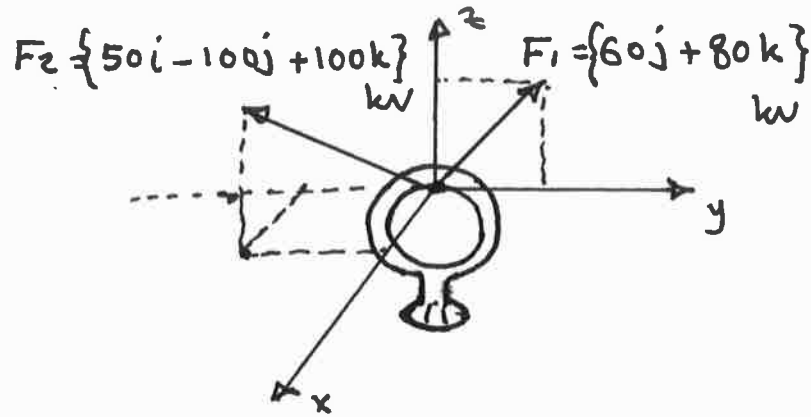

$$\begin{aligned}\vec{F}_R &= \sum \vec{F} = \vec{F}_1 + \vec{F}_2 \quad (\text{vector addition}) \\ &= (60\mathbf{j} + 80\mathbf{k}) + (50\mathbf{i} - 100\mathbf{j} + 100\mathbf{k}) \\ &= \{50\mathbf{i} - 40\mathbf{j} + 180\mathbf{k}\} \text{ kW}\end{aligned}$$

The magnitude of the resultant:

$$F_R = \sqrt{(50)^2 + (-40)^2 + (180)^2} = \boxed{191 \text{ kW}}$$

The direction angles α , β , and γ :

$$\cos \alpha = \frac{F_x}{F_R} = \frac{50}{191} = 0.2617 \Rightarrow \boxed{\alpha = 74.8^\circ}$$

$$\cos \beta = \frac{F_y}{F_R} = \frac{-40}{191} = -0.2094 \Rightarrow \boxed{\beta = 102^\circ}$$

$$\cos \gamma = \frac{F_z}{F_R} = 0.9422 \Rightarrow \boxed{\gamma = 19.6^\circ}$$

$$F_R = 191 \text{ kW}$$

Notice that $\beta > 90$
since F_y is negative.

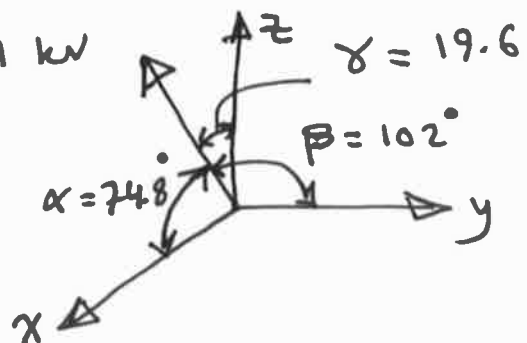

Ex. 3: Express the force F in Cartesian vector. Also find the angles α , β and γ .

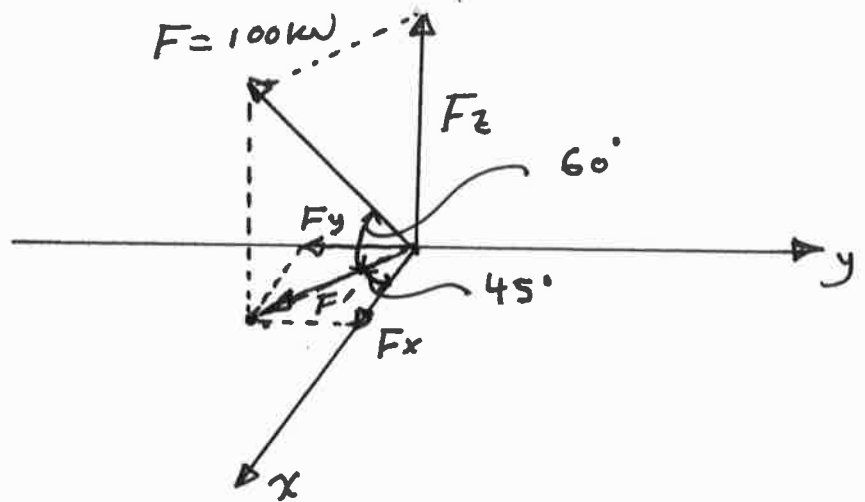

Sol.

$$\begin{aligned} \vec{F} &= \vec{F}' + \vec{F}_z \\ \vec{F}' &= \vec{F}_x + \vec{F}_y \end{aligned} \quad \left. \vphantom{\begin{aligned} \vec{F} &= \vec{F}' + \vec{F}_z \\ \vec{F}' &= \vec{F}_x + \vec{F}_y \end{aligned}} \right\} \text{vector addition}$$

$$\text{Now: } F_z = F \sin 60 = 100 \sin 60 = 86.6 \text{ kW}$$

$$F' = F \cos 60 = 100 \cos 60 = 50 \text{ kW}$$

$$F_x = F' \cos 45 = 50 \cos 45 = 35.4 \text{ kW}$$

$$F_y = F' \sin 45 = 50 \sin 45 = 35.4 \text{ kW}$$

$$\Rightarrow \vec{F} = \vec{F}' + \vec{F}_z = \vec{F}_x + \vec{F}_y + \vec{F}_z$$

$$\Rightarrow \boxed{\vec{F} = 35.4 \mathbf{i} - 35.4 \mathbf{j} + 86.6 \mathbf{k}}$$

$$F = \sqrt{(35.4)^2 + (-35.4)^2 + (86.6)^2} = 100 \text{ kW}$$

$$\Rightarrow \alpha = \cos^{-1} \frac{F_x}{F} = \cos^{-1} \frac{35.4}{100} = 69.3^\circ$$

$$\beta = \cos^{-1} \frac{F_y}{F} = \cos^{-1} \frac{-35.4}{100} = 111^\circ$$

$$\gamma = \cos^{-1} \frac{F_z}{F} = \cos^{-1} \frac{86.6}{100} = 30^\circ$$

Position Vector: A position vector r is defined as a fixed vector which locates a point in space relative to another point.

To find r :

By vector addition:

$$\vec{r}_B = \vec{r}_A + \vec{r}$$

$$\Rightarrow \vec{r} = \vec{r}_B - \vec{r}_A$$

$$\Rightarrow \vec{r} = (x_B i + y_B j + z_B k) - (x_A i + y_A j + z_A k)$$

$$\Rightarrow \boxed{\vec{r} = (x_B - x_A) i + (y_B - y_A) j + (z_B - z_A) k}$$

(Subtracting the coordinates of the tail of the vector \vec{r} from the coordinates of the head)

Example: Determine the length of the member AB.

Sol.

The coordinates of

A is $(1, 0, -3)$

B is $(-2, 2, 3)$

$$\vec{r}_{AB} = \vec{r}_B - \vec{r}_A$$

$$= (-2 - 1) i + (2 - 0) j + (3 - (-3)) k$$

$$\Rightarrow \vec{r}_{AB} = [-3 i + 2 j + 6 k] \text{ m}$$

$$\Rightarrow L_{AB} = \sqrt{(-3)^2 + (2)^2 + (6)^2} = 7 \text{ m}$$

Note

$$\vec{r}_{BA} = 3 i - 2 j - 6 k$$

(36)

$$L_{BA} = L_{AB}$$

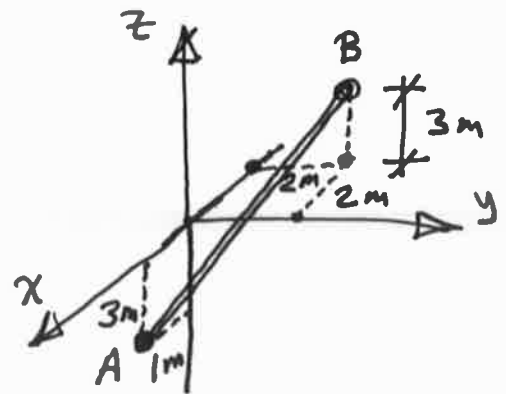
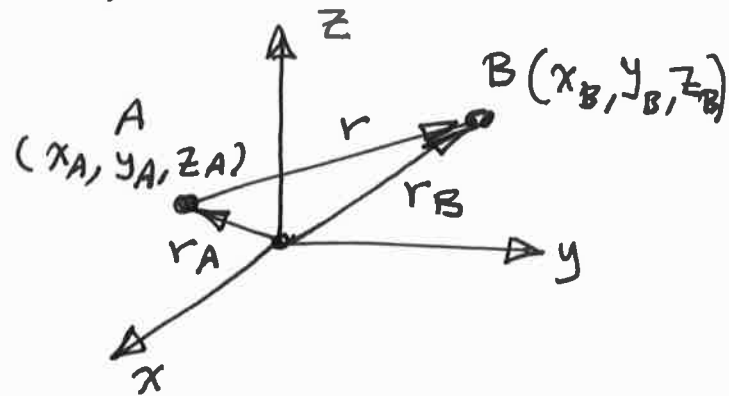

Force Vector Directed Along a Line:

To represent the force directed along an element AB, the unit vector u is multiplied by the magnitude of the force.

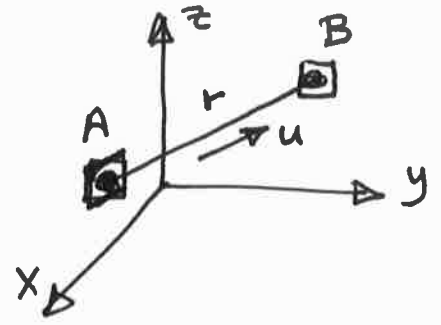

The unit vector $u = \frac{\vec{r}}{r}$

[\vec{r} : vector, r : magnitude]

$\Rightarrow \vec{F} = F \vec{u} = F \frac{\vec{r}}{r}$

Example: A man pulls on the cord at point B with a force 350 N. Represent this force acting on the support A as a Cartesian vector, and determine the direction.

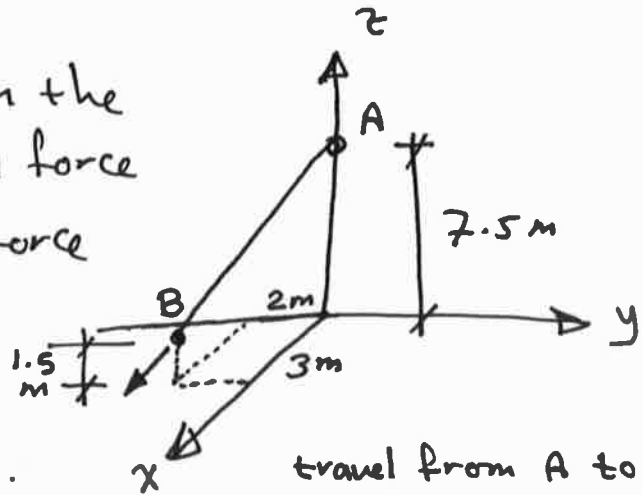

travel from A to B

Sol. We can find r directly: $\vec{r} = \{3i - 2j - 6k\}m$

$$r = \sqrt{(3)^2 + (-2)^2 + (-6)^2} = 7m$$

$$\vec{u} = \vec{r} / r = \frac{3}{7}i - \frac{2}{7}j - \frac{6}{7}k$$

$$\vec{F} = F \vec{u} = 350 \left(\frac{3}{7}i - \frac{2}{7}j - \frac{6}{7}k \right) = \{150i - 100j - 300k\} N$$

$$\alpha = \cos^{-1} \frac{r_x}{r} = \cos^{-1} \frac{3}{7} = 64.6^\circ$$

$$\beta = \cos^{-1} \frac{r_y}{r} = \cos^{-1} \frac{-2}{7} = 107^\circ$$

$$\gamma = \cos^{-1} \frac{r_z}{r} = \cos^{-1} \frac{-6}{7} = 149^\circ$$

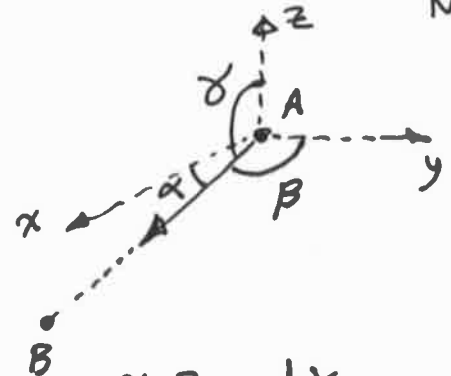

$\alpha, \beta,$ and γ are measured between r (or \vec{F}) and the axes with origin at A.

Dot Product :

The dot product is a multiplication of two vectors.

It is defined as: $\vec{A} \cdot \vec{B} = AB \cos \theta$

Where \vec{A} and \vec{B} are vectors and θ is the angle between their tails in which $0 \leq \theta \leq 180^\circ$.

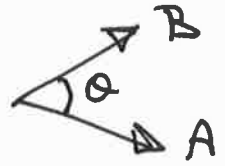

Laws of Operations for Dot Product:

1. Commutative law: $\vec{A} \cdot \vec{B} = \vec{B} \cdot \vec{A}$

2. Multiplication by a scalar:

$$\alpha(\vec{A} \cdot \vec{B}) = (\alpha\vec{A}) \cdot \vec{B} = \vec{A} \cdot (\alpha\vec{B})$$

3. Distributive law: $\vec{A} \cdot (\vec{B} + \vec{C}) = (\vec{A} \cdot \vec{B}) + (\vec{A} \cdot \vec{C})$

Dot Product in Cartesian Vector Form:

We have $\vec{A} = A_x i + A_y j + A_z k$

$$\vec{B} = B_x i + B_y j + B_z k$$

$$\begin{aligned} \Rightarrow \vec{A} \cdot \vec{B} &= (A_x i + A_y j + A_z k) \cdot (B_x i + B_y j + B_z k) \\ &= A_x B_x (i \cdot i) + A_x B_y (i \cdot j) + A_x B_z (i \cdot k) \\ &\quad + A_y B_x (j \cdot i) + A_y B_y (j \cdot j) + A_y B_z (j \cdot k) \\ &\quad + A_z B_x (k \cdot i) + A_z B_y (k \cdot j) + A_z B_z (k \cdot k) \end{aligned}$$

But $i \cdot i = (1)(1) \cos 0 = 1$, $i \cdot j = (1)(1) \cos 90 = 0$
 $i \cdot k = (1)(1) \cos 90 = 0$, $j \cdot k = (1)(1) \cos 90 = 0$

$$\Rightarrow \vec{A} \cdot \vec{B} = A_x B_x + A_y B_y + A_z B_z$$

Applications of Dot Product:

There are two main applications (especially in 3D)

1. Finding the angle between two lines (or vectors):

$$\vec{A} \cdot \vec{B} = AB \cos \theta \Rightarrow \cos \theta = \frac{\vec{A} \cdot \vec{B}}{AB}$$

$$\Rightarrow \theta = \cos^{-1} \frac{\vec{A} \cdot \vec{B}}{AB}, \quad 0 \leq \theta \leq 180^\circ$$

2. Finding the components that are parallel and perpendicular to a vector (or line):

if u_a is a unit vector
in a -direction,

We have $A_a = A \cos \theta$

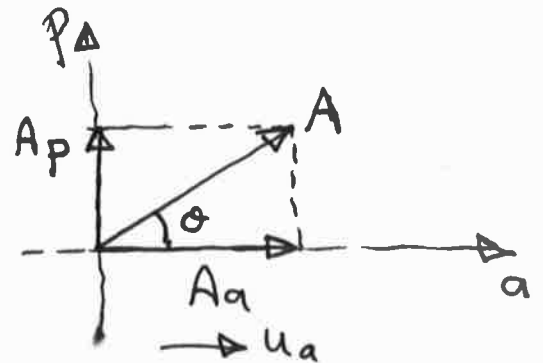

But $\overbrace{\vec{A} \cdot \vec{u}_a}^{\text{dot product}} = A u_a \cos \theta = A \cos \theta$ [since $u_a = 1$]

$$\Rightarrow \boxed{A_a = \vec{A} \cdot \vec{u}_a}$$

The perpendicular component A_p is determined
as follows:

$$\text{We have } \vec{A} = \vec{A}_a + \vec{A}_p \Rightarrow \boxed{\vec{A}_p = \vec{A} - \vec{A}_a}$$

Notes * A_a is also called the projection of A along a -axis.

* A_p is also called the projection of A along p -axis

Example: Determine the angle θ between the force F and the pipe segment BA , also find the projection of F along this segment.

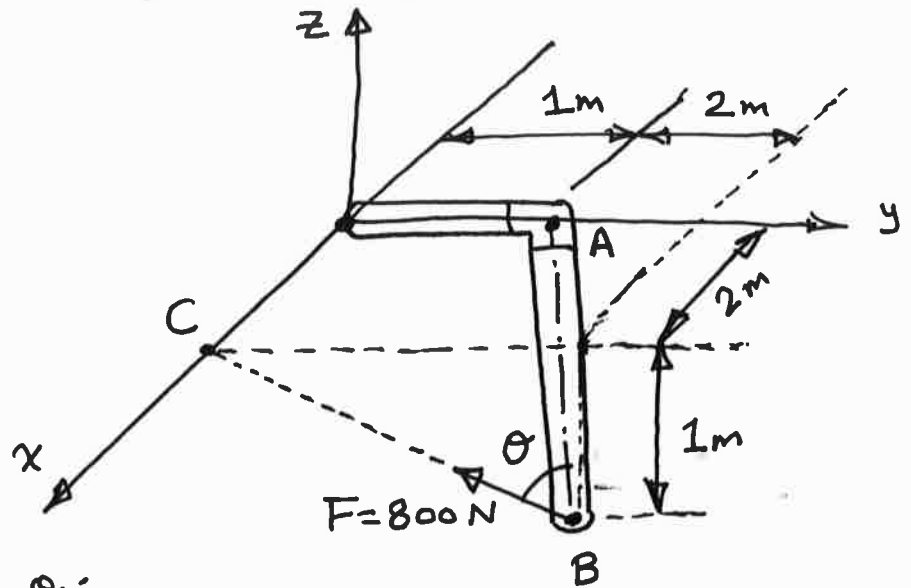

Solution: To find θ :

$$\vec{r}_{BA} = -2i - 2j + 1k \Rightarrow r_{BA} = \sqrt{(-2)^2 + (-2)^2 + (1)^2} = 3 \text{ m}$$

$$\vec{r}_{BC} = -3j + 1k \Rightarrow r_{BC} = \sqrt{(-3)^2 + (1)^2} = \sqrt{10} \text{ m}$$

$$\Rightarrow \theta = \cos^{-1} \frac{\vec{r}_{BA} \cdot \vec{r}_{BC}}{r_{BA} \cdot r_{BC}} = \cos^{-1} \frac{(-2)(0) + (-2)(-3) + (1)(1)}{3\sqrt{10}} = \boxed{42.5^\circ}$$

To find the component of F along BA (F_{BA}):

We have: $F_{BA} = \vec{F} \cdot \vec{u}_{BA}$

$$\vec{u}_{BA} = \frac{\vec{r}_{BA}}{r_{BA}} = \frac{-2}{3}i - \frac{2}{3}j + \frac{1}{3}k$$

$$\vec{F} = F \cdot \vec{u}_{BC} = 800 \left(\frac{-3}{\sqrt{10}}j + \frac{1}{\sqrt{10}}k \right) = -758.9j + 253k$$

$$\begin{aligned} \Rightarrow F_{BA} &= \vec{F} \cdot \vec{u}_{BA} = (-758.9j + 253k) \cdot \left(\frac{-2}{3}i - \frac{2}{3}j + \frac{1}{3}k \right) \\ &= (0)\left(\frac{-2}{3}\right) + (-758.9)\left(\frac{-2}{3}\right) + (253)\left(\frac{1}{3}\right) = \boxed{590 \text{ N}} \end{aligned}$$

Or: $F_{BA} = F \cos \theta = 800 \cos 42.5 = \boxed{590 \text{ N}}$ same answer.

2-90.

Express \mathbf{F}_B and \mathbf{F}_C in Cartesian vector form.

SOLUTION

Force Vectors: The unit vectors \mathbf{u}_B and \mathbf{u}_C of \mathbf{F}_B and \mathbf{F}_C must be determined first. From Fig. *a*

$$\mathbf{u}_B = \frac{\mathbf{r}_B}{r_B} = \frac{(-1.5 - 0.5)\mathbf{i} + [-2.5 - (-1.5)]\mathbf{j} + (2 - 0)\mathbf{k}}{\sqrt{(-1.5 - 0.5)^2 + [-2.5 - (-1.5)]^2 + (2 - 0)^2}}$$

$$= -\frac{2}{3}\mathbf{i} - \frac{1}{3}\mathbf{j} + \frac{2}{3}\mathbf{k}$$

$$\mathbf{u}_C = \frac{\mathbf{r}_C}{r_C} = \frac{(-1.5 - 0.5)\mathbf{i} + [0.5 - (-1.5)]\mathbf{j} + (3.5 - 0)\mathbf{k}}{\sqrt{(-1.5 - 0.5)^2 + [0.5 - (-1.5)]^2 + (3.5 - 0)^2}}$$

$$= -\frac{4}{9}\mathbf{i} + \frac{4}{9}\mathbf{j} + \frac{7}{9}\mathbf{k}$$

Thus, the force vectors \mathbf{F}_B and \mathbf{F}_C are given by

$$\mathbf{F}_B = F_B \mathbf{u}_B = 600 \left(-\frac{2}{3}\mathbf{i} - \frac{1}{3}\mathbf{j} + \frac{2}{3}\mathbf{k} \right) = \{-400\mathbf{i} - 200\mathbf{j} + 400\mathbf{k}\} \text{ N}$$

$$\mathbf{F}_C = F_C \mathbf{u}_C = 450 \left(-\frac{4}{9}\mathbf{i} + \frac{4}{9}\mathbf{j} + \frac{7}{9}\mathbf{k} \right) = \{-200\mathbf{i} + 200\mathbf{j} + 350\mathbf{k}\} \text{ N}$$

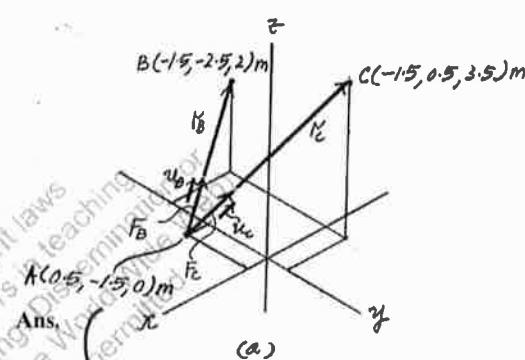
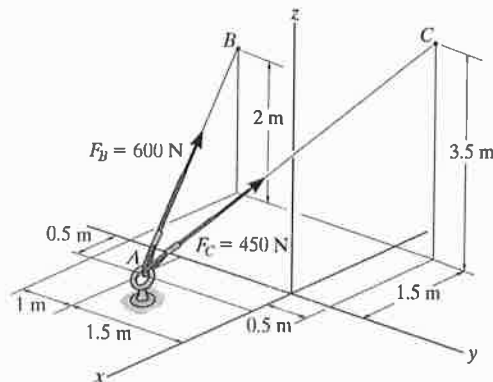

Ans.

Ans.

$$A(0.5, -1.5, 0) \text{ m}$$

This work is protected by United States copyright laws and is provided solely for the use of instructors in teaching their courses and assessing student learning on the Worktext. Sale of any part of this work (including on the Worktext) will destroy the integrity of the work and is not permitted.

2-94.

The tower is held in place by three cables. If the force of each cable acting on the tower is shown, determine the magnitude and coordinate direction angles α, β, γ of the resultant force. Take $x = 20$ m, $y = 15$ m.

SOLUTION

$$\mathbf{F}_{DA} = 400 \left(\frac{20}{34.66} \mathbf{i} + \frac{15}{34.66} \mathbf{j} - \frac{24}{34.66} \mathbf{k} \right) \text{ N}$$

$$\mathbf{F}_{DB} = 800 \left(\frac{-6}{25.06} \mathbf{i} + \frac{4}{25.06} \mathbf{j} - \frac{24}{25.06} \mathbf{k} \right) \text{ N}$$

$$\mathbf{F}_{DC} = 600 \left(\frac{16}{34} \mathbf{i} - \frac{18}{34} \mathbf{j} - \frac{24}{34} \mathbf{k} \right) \text{ N}$$

$$\mathbf{F}_R = \mathbf{F}_{DA} + \mathbf{F}_{DB} + \mathbf{F}_{DC}$$

$$= \{321.66\mathbf{i} - 16.82\mathbf{j} - 1466.71\mathbf{k}\} \text{ N}$$

$$F_R = \sqrt{(321.66)^2 + (-16.82)^2 + (-1466.71)^2}$$

$$= 1501.66 \text{ N} = 1.50 \text{ kN}$$

$$\alpha = \cos^{-1} \left(\frac{321.66}{1501.66} \right) = 77.6^\circ$$

$$\beta = \cos^{-1} \left(\frac{-16.82}{1501.66} \right) = 90.6^\circ$$

$$\gamma = \cos^{-1} \left(\frac{-1466.71}{1501.66} \right) = 168^\circ$$

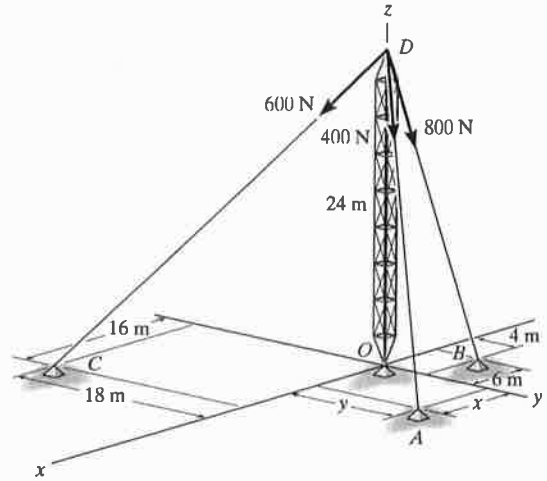

This work is protected by United States copyright laws and is provided solely for the use of instructors in teaching their courses and assessing student learning. Dissemination or sale of any part of this work (including on the World Wide Web) will destroy the integrity of the work and is not permitted.

Ans.
Ans.
Ans.
Ans.

Note: The values of u_{DA} , u_{DB} , and u_{DC} have been determined as before.

For example:

$$u_{DA} = \frac{\vec{r}_{DA}}{r_{DA}} = \frac{20\mathbf{i} + 15\mathbf{j} - 24\mathbf{k}}{\sqrt{(20)^2 + (15)^2 + (-24)^2}} = \frac{20\mathbf{i} + 15\mathbf{j} - 24\mathbf{k}}{34.66}$$

42

*2-100.

The guy wires are used to support the telephone pole. Represent the force in each wire in Cartesian vector form. Neglect the diameter of the pole.

SOLUTION

Unit Vector:

$$\mathbf{r}_{AC} = [(-1 - 0)\mathbf{i} + (4 - 0)\mathbf{j} + (0 - 4)\mathbf{k}] \text{ m} = [-1\mathbf{i} + 4\mathbf{j} - 4\mathbf{k}] \text{ m}$$

$$r_{AC} = \sqrt{(-1)^2 + 4^2 + (-4)^2} = 5.745 \text{ m}$$

$$\mathbf{u}_{AC} = \frac{\mathbf{r}_{AC}}{r_{AC}} = \frac{-1\mathbf{i} + 4\mathbf{j} - 4\mathbf{k}}{5.745} = -0.1741\mathbf{i} + 0.6963\mathbf{j} - 0.6963\mathbf{k}$$

$$\mathbf{r}_{BD} = [(2 - 0)\mathbf{i} + (-3 - 0)\mathbf{j} + (0 - 5.5)\mathbf{k}] \text{ m} = [2\mathbf{i} - 3\mathbf{j} - 5.5\mathbf{k}] \text{ m}$$

$$r_{BD} = \sqrt{2^2 + (-3)^2 + (-5.5)^2} = 6.576 \text{ m}$$

$$\mathbf{u}_{BD} = \frac{\mathbf{r}_{BD}}{r_{BD}} = \frac{2\mathbf{i} - 3\mathbf{j} - 5.5\mathbf{k}}{6.576} = 0.3041\mathbf{i} - 0.4562\mathbf{j} - 0.8363\mathbf{k}$$

Force Vector:

$$\begin{aligned} \mathbf{F}_A &= F_A \mathbf{u}_{AC} = 250[-0.1741\mathbf{i} + 0.6963\mathbf{j} - 0.6963\mathbf{k}] \text{ N} \\ &= [-43.52\mathbf{i} + 174.08\mathbf{j} - 174.08\mathbf{k}] \text{ N} \\ &= [-43.5\mathbf{i} + 174\mathbf{j} - 174\mathbf{k}] \text{ N} \end{aligned}$$

Ans.

$$\begin{aligned} \mathbf{F}_B &= F_B \mathbf{u}_{BD} = 175[0.3041\mathbf{i} + 0.4562\mathbf{j} - 0.8363\mathbf{k}] \text{ N} \\ &= [53.22\mathbf{i} - 79.83\mathbf{j} - 146.36\mathbf{k}] \text{ N} \\ &= [53.2\mathbf{i} - 79.8\mathbf{j} - 146\mathbf{k}] \text{ N} \end{aligned}$$

Ans.

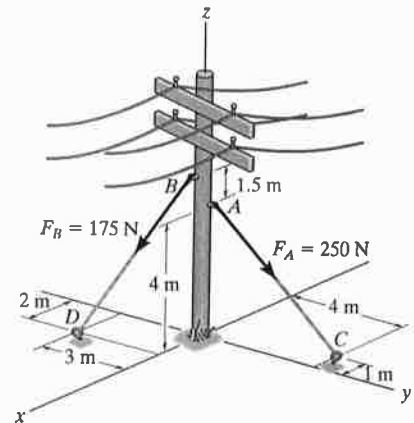

43

2-102.

Each of the four forces acting at E has a magnitude of 28 kN. Express each force as a Cartesian vector and determine the resultant force.

SOLUTION

$$\mathbf{F}_{EA} = 28\left(\frac{6}{14}\mathbf{i} - \frac{4}{14}\mathbf{j} - \frac{12}{14}\mathbf{k}\right)$$

$$\mathbf{F}_{EA} = \{12\mathbf{i} - 8\mathbf{j} - 24\mathbf{k}\} \text{ kN}$$

$$\mathbf{F}_{EB} = 28\left(\frac{6}{14}\mathbf{i} + \frac{4}{14}\mathbf{j} - \frac{12}{14}\mathbf{k}\right)$$

$$\mathbf{F}_{EB} = \{12\mathbf{i} + 8\mathbf{j} - 24\mathbf{k}\} \text{ kN}$$

$$\mathbf{F}_{EC} = 28\left(\frac{-6}{14}\mathbf{i} + \frac{4}{14}\mathbf{j} - \frac{12}{14}\mathbf{k}\right)$$

$$\mathbf{F}_{EC} = \{-12\mathbf{i} + 8\mathbf{j} - 24\mathbf{k}\} \text{ kN}$$

$$\mathbf{F}_{ED} = 28\left(\frac{-6}{14}\mathbf{i} - \frac{4}{14}\mathbf{j} - \frac{12}{14}\mathbf{k}\right)$$

$$\mathbf{F}_{ED} = \{-12\mathbf{i} - 8\mathbf{j} - 24\mathbf{k}\} \text{ kN}$$

$$\begin{aligned} \mathbf{F}_R &= \mathbf{F}_{EA} + \mathbf{F}_{EB} + \mathbf{F}_{EC} + \mathbf{F}_{ED} \\ &= \{-96\mathbf{k}\} \text{ kN} \end{aligned}$$

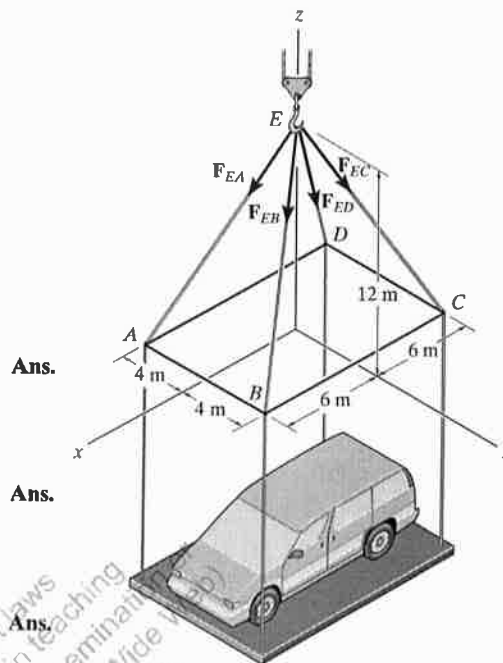

This work is protected by United States copyright laws and is provided solely for the use of instructors in teaching their courses and assessing student learning. Dissemination or sale of any part of this work (including on the World Wide Web) will destroy the integrity of the work and is not permitted.

2-107.

The chandelier is supported by three chains which are concurrent at point O . If the resultant force at O has a magnitude of 130 lb and is directed along the negative z axis, determine the force in each chain.

SOLUTION

$$\mathbf{F}_C = F \frac{(4\mathbf{j} - 6\mathbf{k})}{\sqrt{4^2 + (-6)^2}} = 0.5547 F\mathbf{j} - 0.8321 F\mathbf{k}$$

$$\mathbf{F}_A = \mathbf{F}_B = \mathbf{F}_C$$

$$F_{Rz} = \Sigma F_z; \quad 130 = 3(0.8321F)$$

$$F = 52.1P$$

Ans.

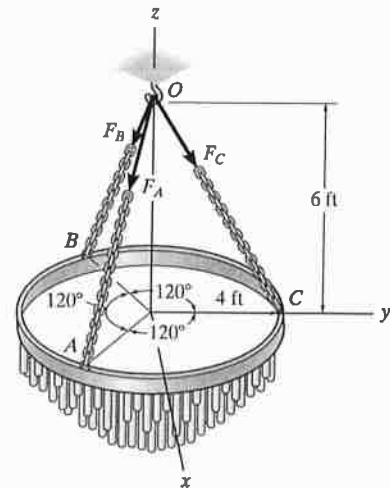

This work is protected by United States copyright laws and is provided solely for the use of instructors in teaching their courses and assessing student learning. Dissemination or sale of any part of this work (including on the World Wide Web) will destroy the integrity of the work and is not permitted.

45

*2-116.

Determine the magnitude of the projected component of force F_{AB} acting along the z axis.

SOLUTION

Unit Vector: The unit vector u_{AB} must be determined first. From Fig. a,

$$u_{AB} = \frac{r_{AB}}{r_{AB}} = \frac{(18 - 0)i + (-12 - 0)j + (0 - 36)k}{\sqrt{(18 - 0)^2 + (-12 - 0)^2 + (0 - 36)^2}} = \frac{3}{7}i - \frac{2}{7}j - \frac{6}{7}k$$

Thus, the force vector F_{AB} is given by

$$F_{AB} = F_{AB} u_{AB} = 700 \left(\frac{3}{7}i - \frac{2}{7}j - \frac{6}{7}k \right) = \{300i - 200j - 600k\} \text{ lb}$$

Vector Dot Product: The projected component of F_{AB} along the z axis is

$$(F_{AB})_z = F_{AB} \cdot k = (300i - 200j - 600k) \cdot k = -600 \text{ lb}$$

The negative sign indicates that $(F_{AB})_z$ is directed towards the negative z axis. Thus

$$(F_{AB})_z = 600 \text{ lb} \quad \downarrow$$

Ans.

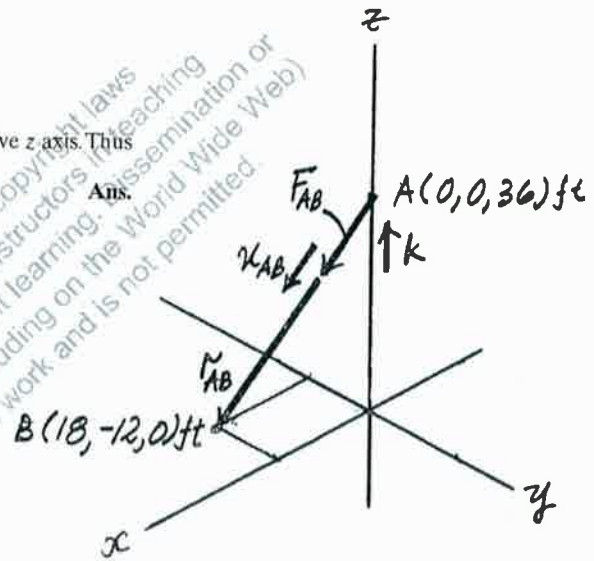
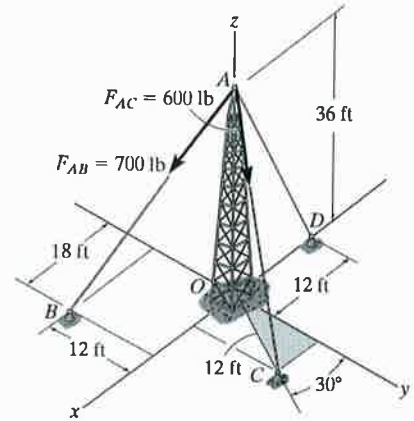

Note

$$u_{AO} = \frac{r_{AO}}{r_{AO}} = \frac{-36k}{36} = -k$$

46

MOMENT AND COUPLE :

Moment of a Force:

The moment of a force about a point or axis provides a measure of the tendency of the force to cause a body to rotate about the point or axis.

From the figure:

The force F and the point O lie in a plane. The moment M about the point O , or about an axis passing through O and perpendicular to the plane is a vector quantity.

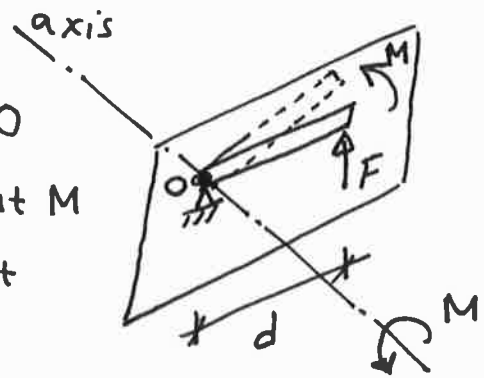

The magnitude of the moment M is: $M = F \cdot d$

Where d is the moment arm (the perpendicular distance from the point O to the line of action of F).

The units of moments are force units times length units, e.g. $N \cdot m$, $lb \cdot ft$, ... etc.

The direction of the moment is represented by \curvearrowright or \curvearrowleft . Here the clockwise rotation is considered to be positive whereas the counterclockwise rotation is negative.

Example: Find the moment of the 5 kN force about the point A.

Solution: $M_A = -5 \times 2 = -10$
 $= 10 \text{ kN}\cdot\text{m} \curvearrowright$

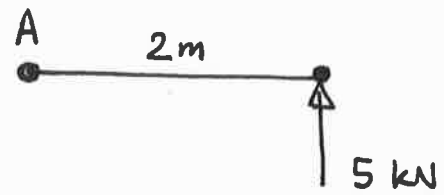

Varignon's Theorem:

Varignon's theorem says that the moment of a force about a point is equal to the sum of the moments of the force's components about the point.

For example:

The moment about A due to F is:

$$M_A = -10 \times 5 = -50$$

$$= 50 \text{ N}\cdot\text{m} \curvearrowright$$

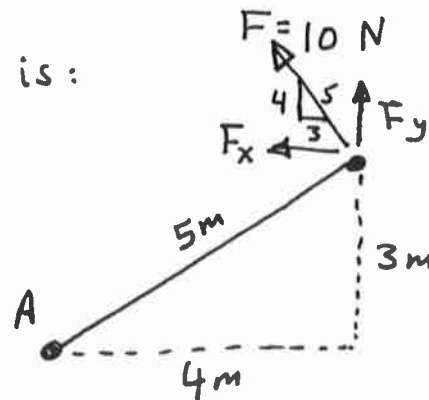

$$F_y = F \left(\frac{4}{5} \right) = 8 \text{ N}$$

$$F_x = F \left(\frac{3}{5} \right) = 6 \text{ N}$$

The moment about A due to F_y is:

$$M_1 = -8 \times 4 = -32 = 32 \text{ N}\cdot\text{m} \curvearrowright$$

The moment about A due to F_x is:

$$M_2 = -6 \times 3 = -18 = 18 \text{ N}\cdot\text{m} \curvearrowright$$

$$M_1 + M_2 = 50 \text{ N}\cdot\text{m} \curvearrowright$$

$$M_A = 50 \text{ N}\cdot\text{m} \curvearrowright$$

$$\Rightarrow M_A = M_1 + M_2$$

O.k.

Resultant Moment of a System of Coplanar Forces:

Resultant moment M_R of a system of coplanar forces can be determined by adding the moments of all forces algebraically, i.e.:

$$M_R = \sum F \cdot d$$

For example:

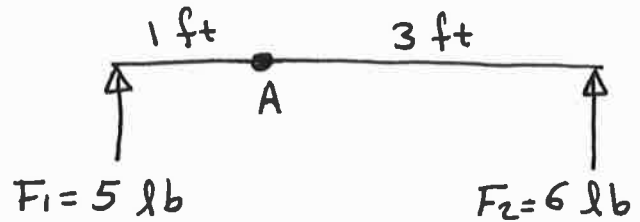

$$\curvearrowright (M_1)_A = 5 \times 1 = 5 \text{ lb}\cdot\text{ft}$$

$$\curvearrowleft (M_2)_A = -6 \times 3 = -18$$

$$= 18 \text{ lb}\cdot\text{ft}$$

$$\Rightarrow \curvearrowright (M_R)_A = 5 - 18 = -13 = 13 \text{ lb}\cdot\text{ft}$$

Couple:

Couple is defined as two parallel forces that have the same magnitude, opposite directions, and are separated by a perpendicular distance.

The moment produced by a couple is called couple moment M_c , and is

$$M_c = F \cdot d$$

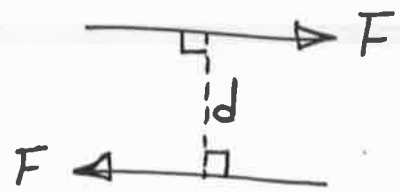

Where, F is a magnitude of one of the forces, and d is the perpendicular distance between the two forces.

The only effect of a couple is to produce a rotation since the resultant of the two forces is zero.

Note: The couple moment is a free vector

(49)

[i.e. it can act at any point on the plane]

Ex. Determine the magnitude and the direction of the couple.

Sol.

$$M_c = F \cdot d$$

$$= 10 \times 2 = 20 \text{ kN}\cdot\text{m} \curvearrowright$$

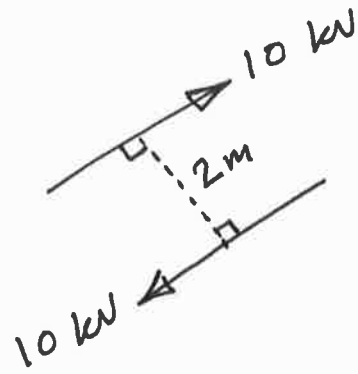

Using of Couples in Statics:

① Changing the line of action of the force:

We want to move the force F from the point A to B .

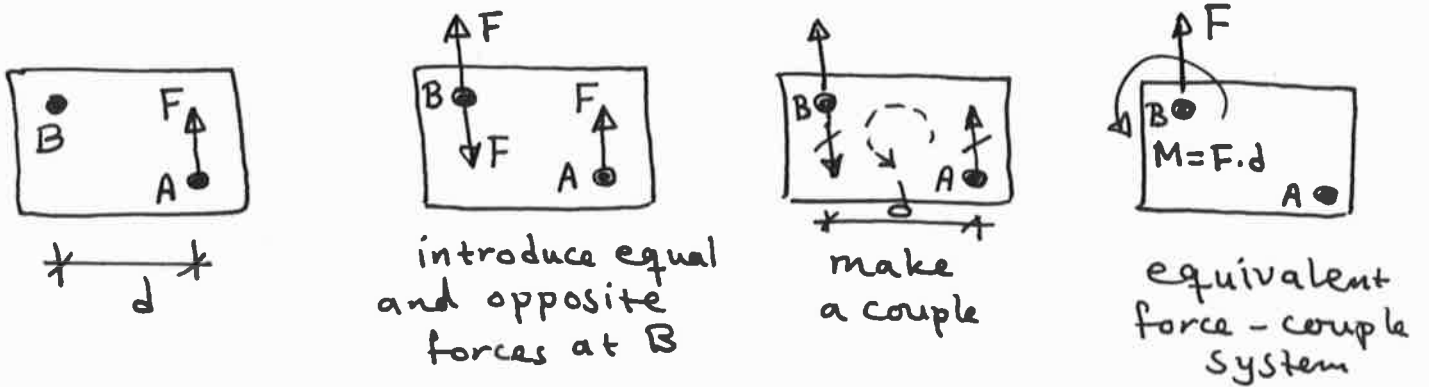

② Reduction of a force system to a force and couple:

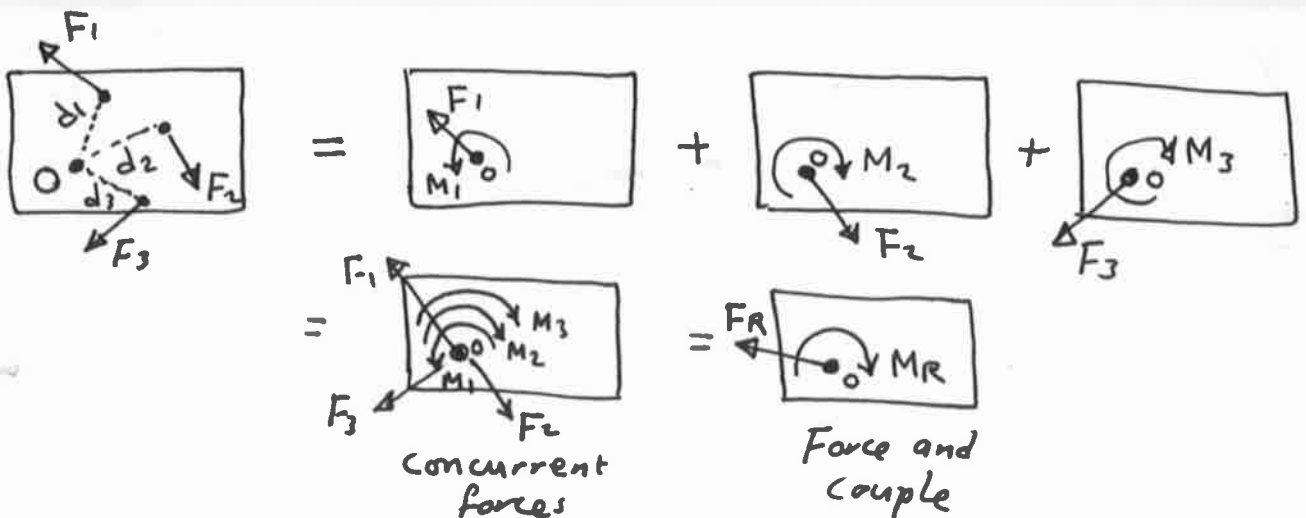

Using the Moment Concept to Find the Resultant of Nonconcurrent Forces:

We want to find the magnitude, direction, and location of the resultant F_R .

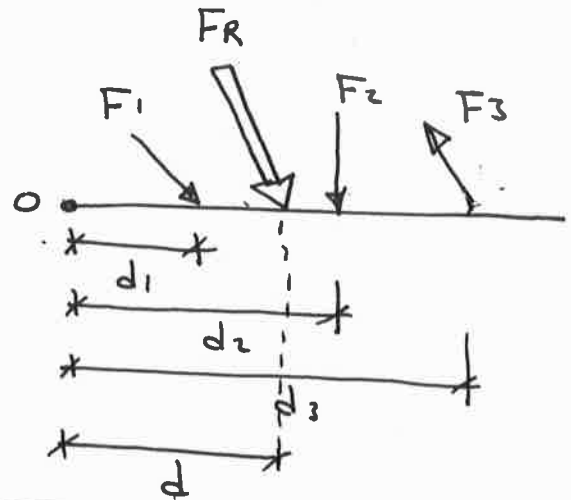

The magnitude: $F_R = \sqrt{(F_{Rx})^2 + (F_{Ry})^2}$

The direction: $\theta = \tan^{-1} \frac{F_{Ry}}{F_{Rx}}$

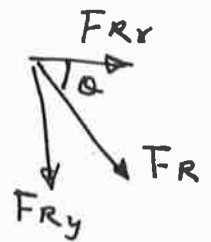

The location: $(F_R)_y \cdot d = (F_1)_y \cdot d_1 + (F_2)_y \cdot d_2 - (F_3)_y \cdot d_3$
 (Varignon's theorem) $[(M_R)_O = \sum M_O]$.
 this equation gives the location d .

Ex. Determine the magnitude, direction, and location of the resultant force from the point A.

S.d.

$+ \downarrow F_R = 8 + 6 + 4 = 18 \text{ kN} \downarrow$

$(\curvearrowright) (M_R)_A = \sum M_A$

$18 * d = 8 * 2 + 6 * 5 + 4 * 6.5$

$\Rightarrow d = 4 \text{ m}$

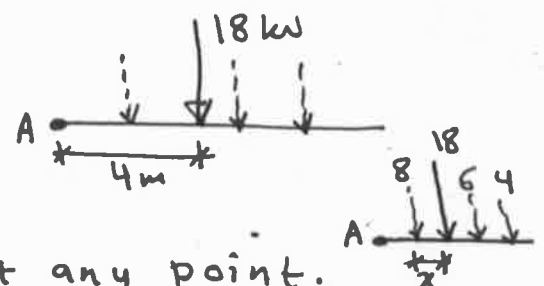
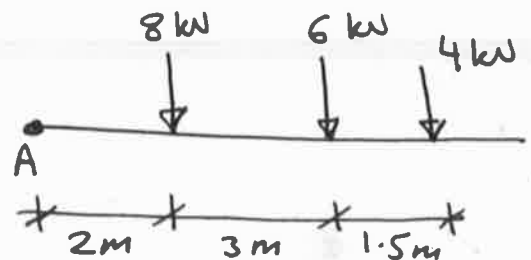

Note: We can find the distance d by taking the moment about any point. For example, about the force 8 kN: $18 * x = 6(3) + 4(4.5)$

$\Rightarrow x = 2 \text{ m} \Rightarrow d = 2 + 2$

Examples about Moments and Couples:

Ex.1: Find the moment of each of the two forces about the point A.

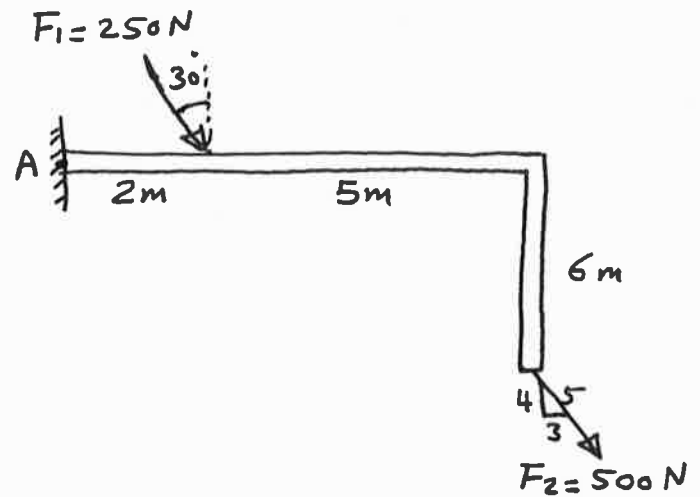

Sol.

For F_1 :

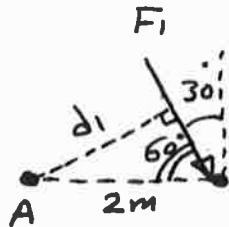

$$\sin 60 = \frac{d_1}{2} \Rightarrow d_1 = 2 \sin 60 = 1.732 \text{ m}$$

$$\curvearrowright M_1 = F_1 \cdot d_1 = 250 \times 1.732 = 433 \text{ N}\cdot\text{m} \quad \curvearrowright$$

For F_2 :

$$\frac{3}{5} = \frac{4}{6} \Rightarrow S = 4.5 \text{ m}$$

$$7 - 4.5 = 2.5 \text{ m}$$

$$\theta = \tan^{-1} \frac{4}{3} = 53.13^\circ$$

$$d_2 = 2.5 \sin 53.13 = 2 \text{ m}$$

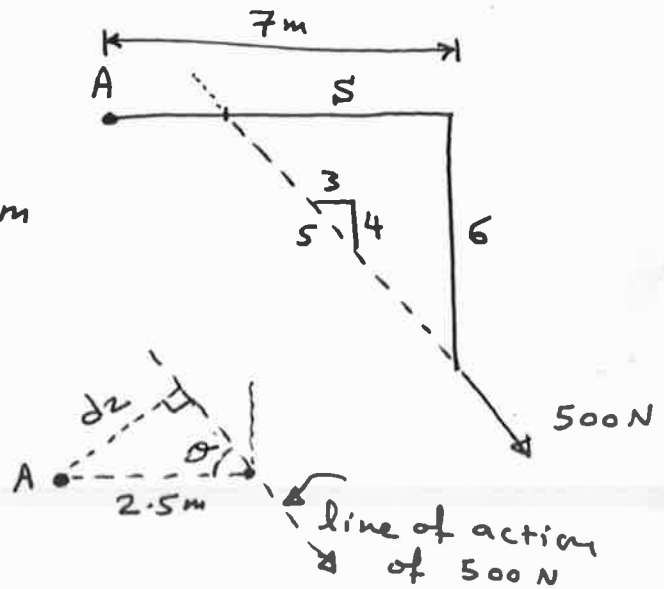

$$\curvearrowright M_2 = F_2 \cdot d_2 = 500 \times 2 = 1000 \text{ N}\cdot\text{m} \quad \curvearrowright$$

Note: It is easier to use Varignon's theorem in this example.

$$\text{For } F_1: M_1 = 250 \cos 30 (2) = 433 \text{ N}\cdot\text{m} \quad \curvearrowright$$

$$\text{For } F_2: M_2 = 500 \left(\frac{4}{5}\right)(7) - 500 \left(\frac{3}{5}\right)(6) = 1000 \text{ N}\cdot\text{m} \quad \curvearrowright$$

(Same results)

Example 2: Determine the moment about point B of each of the three forces acting on the beam.

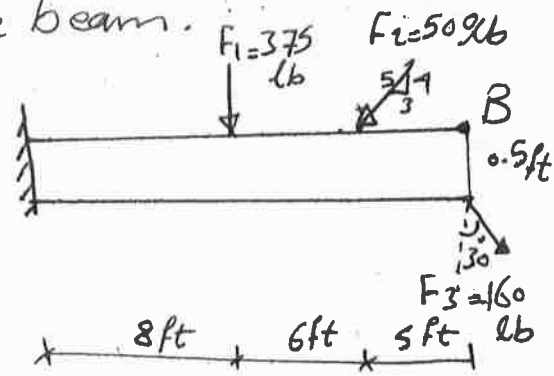

Sol.

$$\begin{aligned} \curvearrowright M_1 &= -375(11) = -4125 \text{ lb}\cdot\text{ft} \\ &= 4125 \text{ lb}\cdot\text{ft} \quad \Rightarrow = 4.125 \text{ Kip}\cdot\text{ft} \end{aligned}$$

$$\begin{aligned} \curvearrowright M_2 &= -500\left(\frac{4}{5}\right)(5) + 0 = -2000 \text{ lb}\cdot\text{ft} \\ &= 2.00 \text{ Kip}\cdot\text{ft} \quad \Rightarrow \end{aligned}$$

$$\begin{aligned} \curvearrowright M_3 &= -160 \sin 30(0.5) + 0 \\ &= -40 \text{ lb}\cdot\text{ft} \quad = 40 \text{ lb}\cdot\text{ft} \quad \Rightarrow \end{aligned}$$

$$\Rightarrow M_R = -6165 = 6165 \text{ lb}\cdot\text{ft}$$

Example 3: For the power pole. Determine the resultant moment at the base (D). Then determine the resultant if line (A) removed.

Sol.

$$\begin{aligned} \curvearrowright M_D &= \sum Fd \\ &= -700(3.5) + 450(3) + 400(4) \\ &= 500 \text{ lb. ft } \curvearrowright \end{aligned}$$

if A removed:

$$\begin{aligned} M_D &= 450(3) + 400(4) \\ &= 2950 \text{ lb. ft } \curvearrowright \end{aligned}$$

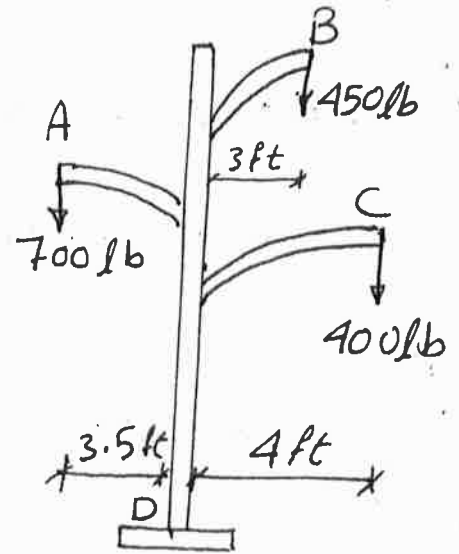

Example 4: Determine the angle (θ) ($0^\circ \leq \theta \leq 180^\circ$) of the force ($F = 40 \text{ lb}$) so that it produce (a) maximum moment about (A) and (b) min. moment about (A).

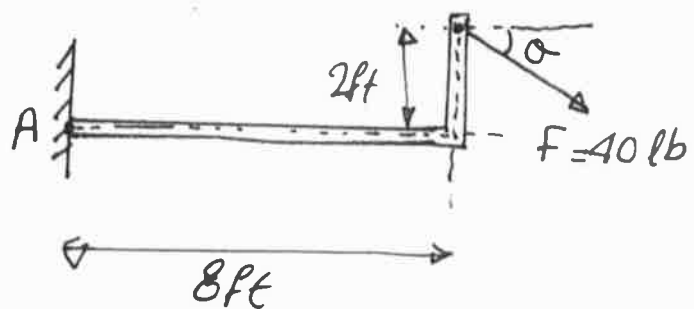

Sol.

(a)

$$\begin{aligned} \textcircled{+} M_{A \text{ Max.}} &= 40 \sqrt{(8)^2 + (2)^2} \\ &= 329.84 \text{ lb} \end{aligned}$$

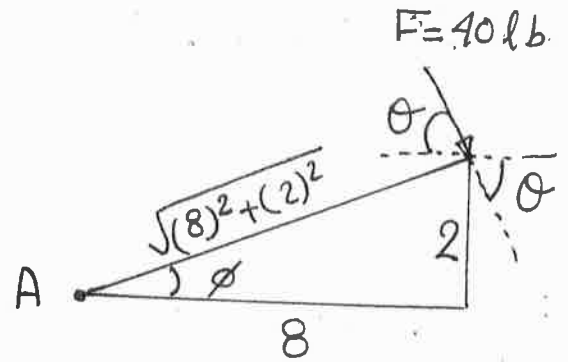

$$\phi = \tan^{-1} \left(\frac{2}{8} \right) = 14.04^\circ$$

$$\Rightarrow \theta = 90^\circ - 14.04^\circ = 75.96^\circ$$

(B) $(M_A)_{\text{min}} = 0$

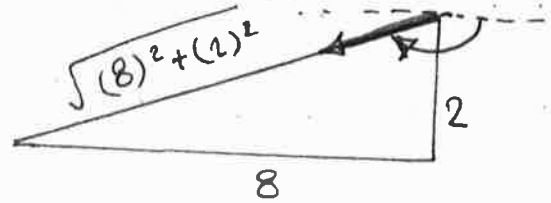

$$\theta = 180 - 14.04 = 165.96^\circ$$

Example (5) Determine the magnitude and ~~direction~~ ^{directional} sense of the resultant moment about (A).

Sol.

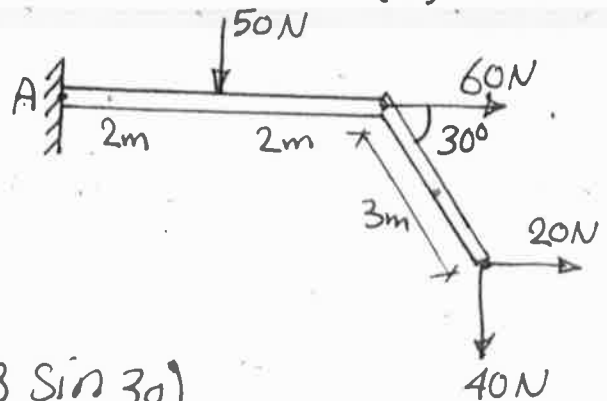

$$\begin{aligned} \textcircled{+} M_{RA} &= M_{Fd} \\ &= 50(2) + 60(0) - 20(3 \sin 30) \\ &\quad + 40(4 + 3 \cos 30) \\ &= 333.92 \text{ N}\cdot\text{m} \end{aligned}$$

Example 6: Determine the moment of the couple.

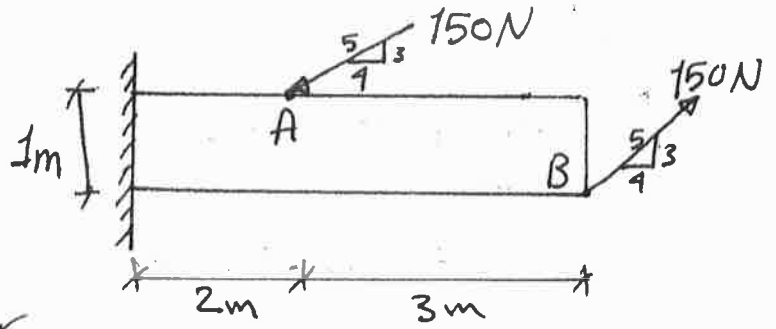

Sol: It is difficult to determine the perpendicular distance between the forces.

Instead we can resolve each force into components and then use Varignon's theorem.

$$F_x = 150 \left(\frac{4}{5} \right) = 120 \text{ N}$$

$$F_y = 150 \left(\frac{3}{5} \right) = 90 \text{ N}$$

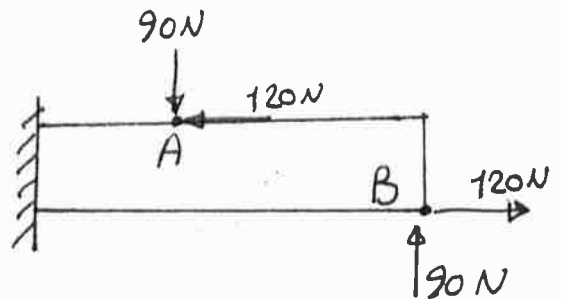

There are two couples:-

$$M_1 = 120(1) = 120 \text{ N}\cdot\text{m} \curvearrowright$$

$$M_2 = 90(3) = 270 \text{ N}\cdot\text{m} \curvearrowright$$

$$\Rightarrow M_c = 120 + 270 = 390 \text{ N}\cdot\text{m} \curvearrowright$$

Notice that the couple moment can be act at any point of the member.

Since the M_c is free vector.

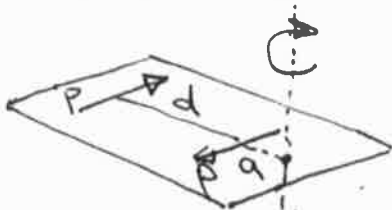

$$\begin{aligned} M &= p(d+a) - p(a) \\ &= pd + pa - pa \\ &= pd \end{aligned}$$

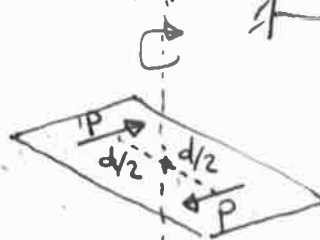

$$M = p\left(\frac{d}{2}\right) + p\left(\frac{d}{2}\right) = pd$$

Example 7: Replace the forces acting on the brace by an equivalent resultant force and couple moment acting at point A.

Sol:

$$F_{Rx} = 700 - 400 \cos 45^\circ$$

$$= -382.8$$

$$= 382.8 \leftarrow$$

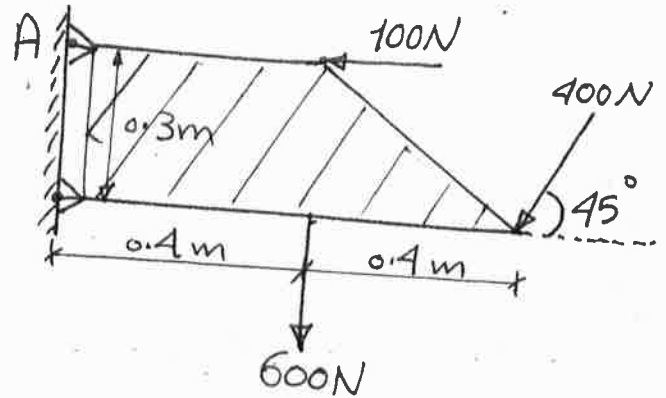

$$F_{Ry} = -600 - 400 \sin 45^\circ = -882.8$$

$$= 882.8 \text{ N } \downarrow$$

$$\Rightarrow F_R = \sqrt{(382.8)^2 + (882.8)^2}$$

$$= 962.2 \text{ N}$$

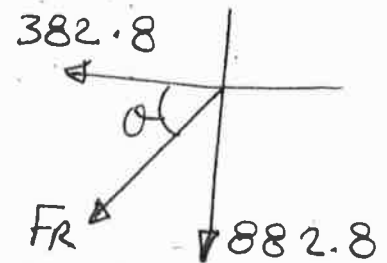

$$\theta = \tan^{-1} \left(\frac{882.8}{382.8} \right) = 66.55^\circ$$



$$\begin{aligned} \curvearrowright M_{RA} &= \sum M_A = 100(0) + 600(0.4) + 400 \sin 45^\circ(0.8) \\ &\quad + 400 \cos 45^\circ(0.3) \\ &= 551.12 \text{ N}\cdot\text{m} \end{aligned}$$

\Rightarrow The equivalent system:

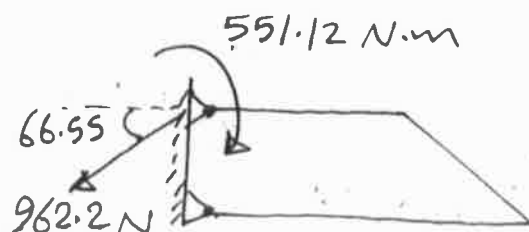

Example 8 Replace the force system acting on the beam by an equivalent force and couple moment at point (B).

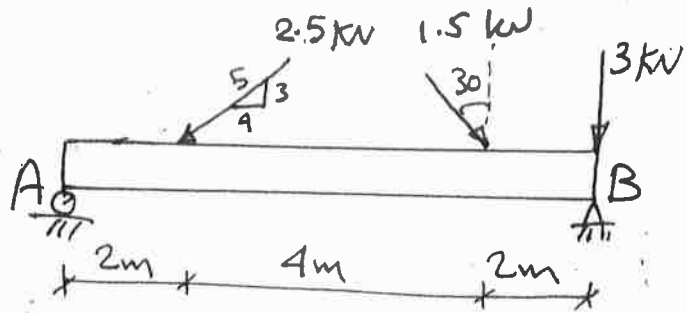

Sol:

$$\begin{aligned} \curvearrowright \sum M_B &= -2.5 \left(\frac{3}{5} \right) \times 6 - 1.5 (\cos 30^\circ) \times 2 = -11.6 \\ &= 11.6 \text{ kN}\cdot\text{m} \curvearrowright \end{aligned}$$

$$\begin{aligned} \rightarrow F_{Rx} &= \sum F_x \\ &= -2.5 \left(\frac{4}{5} \right) + 1.5 \sin 30^\circ = -1.25 \\ &= 1.25 \text{ kN} \leftarrow \end{aligned}$$

$$\begin{aligned} \uparrow F_{Ry} &= \sum F_y \\ &= -2.5 \left(\frac{3}{5} \right) - 1.5 \cos 30^\circ - 3 = 5.8 \\ &= 5.8 \text{ kN} \downarrow \end{aligned}$$

$$\Rightarrow F_R = \sqrt{(1.25)^2 + (5.8)^2} = 5.93 \text{ kN}$$

$$\theta = \tan^{-1} \left(\frac{5.8}{1.25} \right) = 77.8^\circ$$

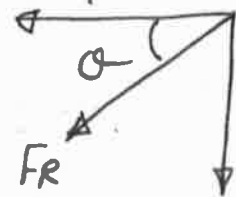

Example 9: Determine the magnitude, direction, and location of the resultant. (with respect to point A).

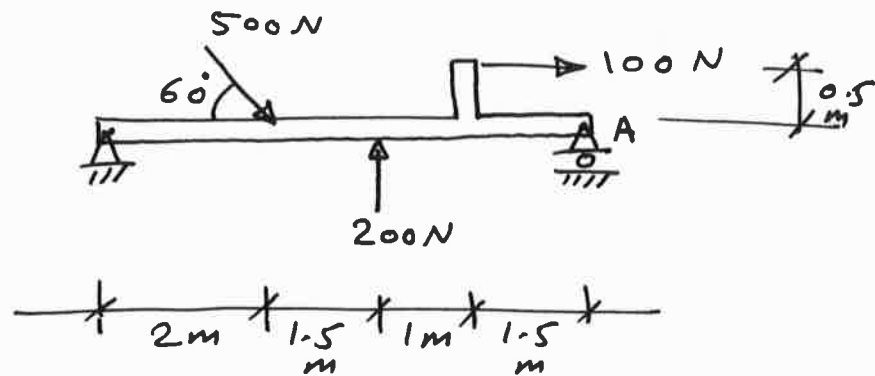

Sol. : $F_{Rx} = 500 \cos 60 + 100 = 350 \text{ N} \rightarrow$

$F_{Ry} = -500 \sin 60 + 200 = -233 = 233 \text{ N} \downarrow$

Magnitude: $F_R = \sqrt{(350)^2 + (233)^2} = 420.5 \text{ N} \downarrow$

direction: $\theta = \tan^{-1} \frac{233}{350} = 33.7^\circ$



location with respect to point A :

$$F_{Ry} \cdot d = F_{1y} \cdot d_1 + F_{2y} \cdot d_2 + F_{3y} \cdot d_3$$

$$-233 \cdot d = -500 \sin 60 (4) + 200 \cdot (2.5) + 100(0.5)$$

$$\Rightarrow d = \frac{1182.1}{233} = 5.07 \text{ m}$$

The equivalent system :

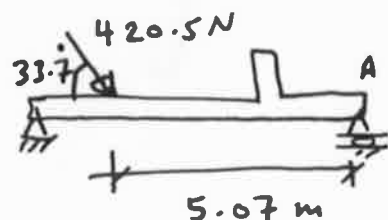

Cross Product:

The formulation of the moment in Cartesian vectors depends on cross product.

The cross product of two vectors \vec{A} and \vec{B} is:

$$\vec{C} = \vec{A} \times \vec{B}$$

The magnitude of the cross product is: $C = AB \sin \theta$

The direction of the cross product vector \vec{C} represents the direction of the vector that is perpendicular to the plane containing the vectors \vec{A} and \vec{B} , based on the right hand rule (curling the fingers of right hand from \vec{A} to \vec{B} , the thumb points in the direction of \vec{C}).

We can write the vector \vec{C} as:

$$\vec{C} = \vec{A} \times \vec{B} = (AB \sin \theta) \vec{u}_c$$

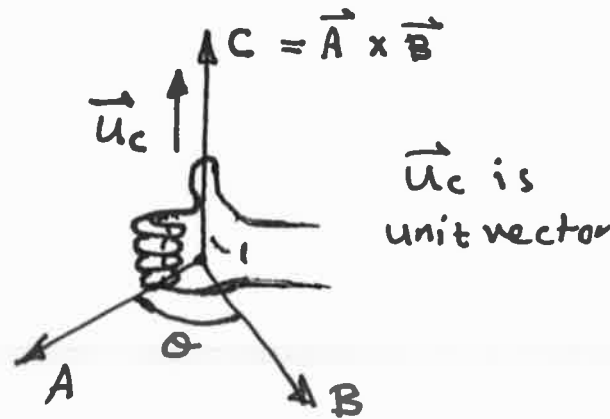

Laws of Operation:

1. $\vec{A} \times \vec{B} \neq \vec{B} \times \vec{A}$ But $(\vec{A} \times \vec{B}) = -(\vec{B} \times \vec{A})$
2. $\alpha(\vec{A} \times \vec{B}) = (\alpha\vec{A}) \times \vec{B} = \vec{A} \times (\alpha\vec{B}) = (\vec{A} \times \vec{B}) \alpha$
3. $\vec{A}(\vec{B} + \vec{D}) = (\vec{A} \times \vec{B}) + (\vec{A} \times \vec{D})$

Note: If $\vec{A} \times \vec{B} = \vec{C}$ then $\vec{B} \times \vec{A} = -\vec{C}$



Now, based on $\vec{C} = AB \sin \theta \vec{u}_c$, we have:

$$\vec{i} \times \vec{j} = ij \sin \theta \vec{u}_c = 1 \times 1 \times \sin 90 \times \vec{k} = \vec{k}$$

$$\vec{i} \times \vec{k} = ik \sin \theta \vec{u}_c = 1 \times 1 \times \sin 90 \times -\vec{j} = -\vec{j}$$

..... etc.



The cross product in Cartesian vector expression is:

$$\begin{aligned} \vec{A} \times \vec{B} &= (A_x \vec{i} + A_y \vec{j} + A_z \vec{k}) \times (B_x \vec{i} + B_y \vec{j} + B_z \vec{k}) \\ &= (A_y B_z - A_z B_y) \vec{i} - (A_x B_z - A_z B_x) \vec{j} + (A_x B_y - A_y B_x) \vec{k} \end{aligned}$$

This value of $\vec{A} \times \vec{B}$ may be written in easier determinant form as:

$$\vec{A} \times \vec{B} = \begin{vmatrix} \vec{i} & \vec{j} & \vec{k} \\ A_x & A_y & A_z \\ B_x & B_y & B_z \end{vmatrix}$$

Moment of a Force in Vector Formulation:

In vector formulation, the moment of a force F about the point O is:

$$\vec{M}_O = \vec{r} \times \vec{F}$$

The magnitude of \vec{M}_O is:

$$M_O = r F \sin \theta$$

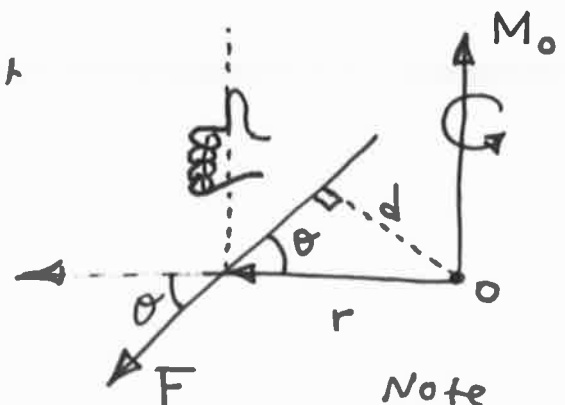

Note

$$r F \sin \theta = F r \sin \theta = F d$$

The direction of \vec{M}_O obtained by curling the fingers of RH from dashed \vec{r} to \vec{F} , then the thumb represents the direction.

Principle of Transmissibility :

The moment M_o can be determined by applying the cross product of the position vector \vec{r} from the point O to any point on the line of action of the force F . This property is called the transmissibility and it is useful in 3D and also 2D because the perpendicular distance d will be not needed

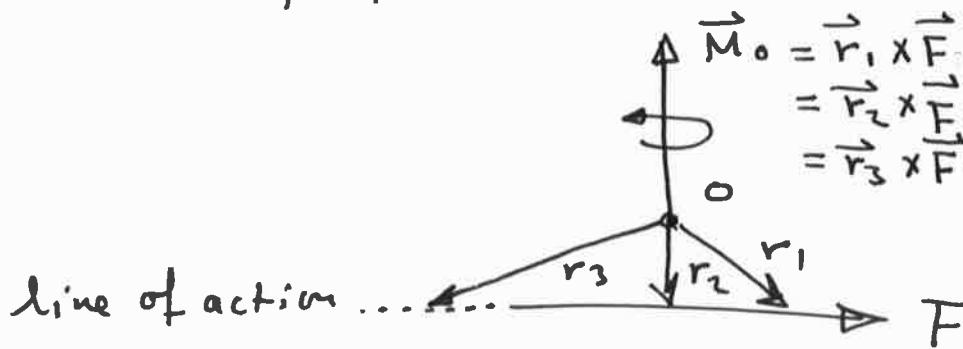

Moment of a Force about a Specified Axis :

For example, to find the moment of the force F about the y -axis :

- Find the moment of F about a point on y -axis (say O).

$$\Rightarrow \vec{M}_o = \vec{r} \times \vec{F}$$

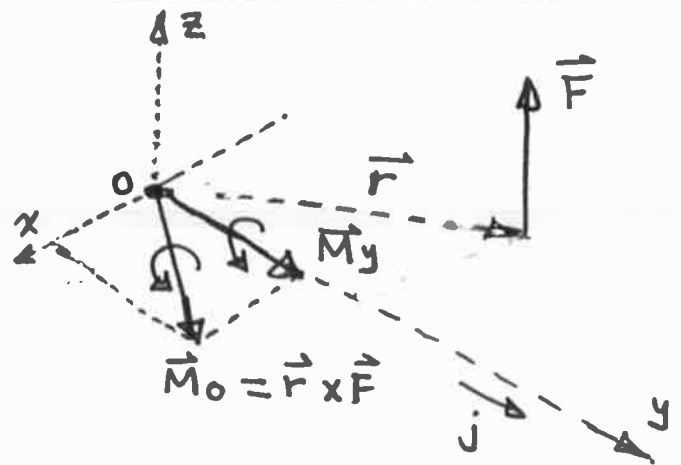

- Use the dot product concept :

$$M_y = \vec{M}_o \cdot \vec{j} = (\vec{r} \times \vec{F}) \cdot \vec{j}$$

M_y : Moment about y -axis
(component of M_o)

In general, to find the moment of a force F about an axis a :

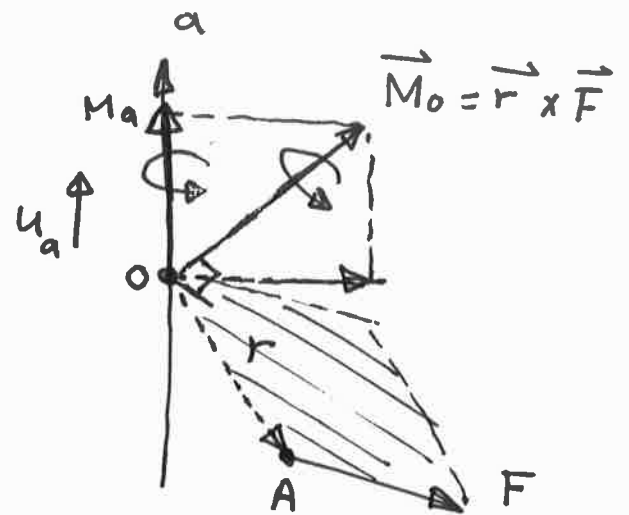

The magnitude of the moment M_a is: $M_a = \vec{M}_O \cdot \vec{u}_a$

$$M_a = \vec{u}_a \cdot (\vec{r} \times \vec{F}) = \begin{vmatrix} u_{ax} & u_{ay} & u_{az} \\ r_x & r_y & r_z \\ F_x & F_y & F_z \end{vmatrix}$$

and $\vec{M}_a = M_a \cdot \vec{u}_a$

where:

u_{ax}, u_{ay}, u_{az} represent the x, y, z components of the unit vector u_a .

r_x, r_y, r_z " " " " " " of the position vector r .

F_x, F_y, F_z " " " " " " of the force F .

The point O is any point on the axis a .

How to find the determinant value?

The signs for cofactors

$$\begin{vmatrix} + & - & + \\ - & + & - \\ + & - & + \end{vmatrix}$$

Calculating the determinants:

1) For 1 x 1 determinant:

$$|a| = a$$

Ex. $|-4| = -4$

2) For 2 x 2 determinant:

$$\begin{vmatrix} a & b \\ c & d \end{vmatrix} = ad - cb$$

Ex. $\begin{vmatrix} 4 & 1 \\ 2 & 3 \end{vmatrix} = 4(3) - 2(1) = 10$

3) For 3 x 3 determinant:

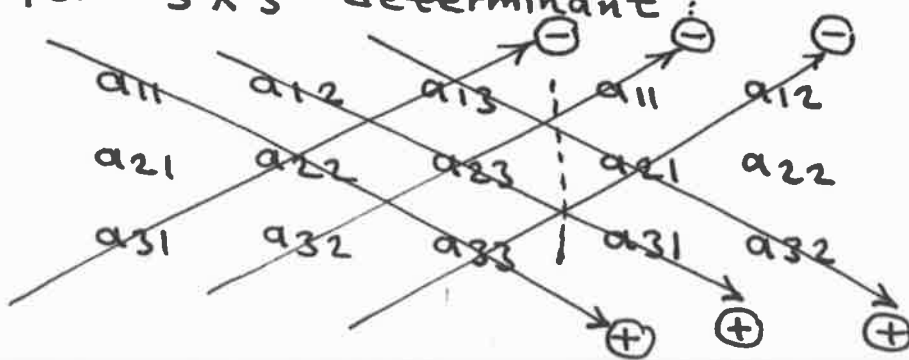

Copy the 1st and 2nd column.

Ex. If:

$$A = \begin{bmatrix} 2 & 1 & 3 \\ 3 & -1 & -2 \\ 2 & 3 & 1 \end{bmatrix} \text{ find det. } A.$$

Sol.

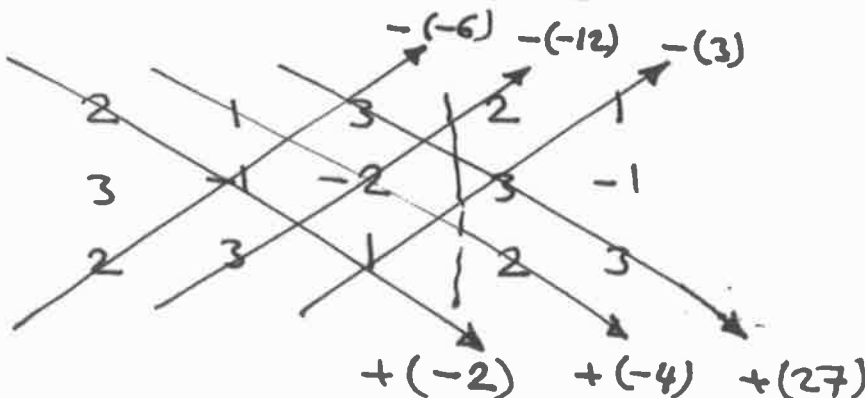

$$\begin{aligned} \det. A &= -2 - 4 \\ &\quad + 27 + 6 \\ &\quad + 12 - 3 \\ &= 36 \end{aligned}$$

④ For determinants of any size:

This method called (expansion by minors):

$$\begin{vmatrix} a_{11} & a_{12} & a_{13} \\ a_{21} & a_{22} & a_{23} \\ a_{31} & a_{32} & a_{33} \end{vmatrix} = a_{11} A_{11} + a_{12} A_{12} + a_{13} A_{13} \quad (\text{from 1}^{\text{st}} \text{ row})$$

$$\text{or} = a_{12} A_{12} + a_{22} A_{22} + a_{32} A_{32} \quad (\text{from 2}^{\text{nd}} \text{ column})$$

or from any row or column.

To simplify the calculation, take row or column with greater number of zeroes.

Ex. Find the determinant for the matrix:

$$A = \begin{bmatrix} 2 & 1 & 3 \\ 3 & -1 & -2 \\ 2 & 3 & 1 \end{bmatrix}$$

Sol. Take 1st row:

$$A_{11} = (-1)^{1+1} \begin{vmatrix} -1 & -2 \\ 3 & 1 \end{vmatrix} = (-1 * 1) - (3 * -2) = 5$$

$$A_{12} = (-1)^{1+2} \begin{vmatrix} 3 & -2 \\ 2 & 1 \end{vmatrix} = -[(3 * 1) - (2 * -2)] = -7$$

$$A_{13} = (-1)^{1+3} \begin{vmatrix} 3 & -1 \\ 2 & 3 \end{vmatrix} = (3 * 3) - (2 * -1) = 11$$

$$\Rightarrow \det. A = a_{11} A_{11} + a_{12} A_{12} + a_{13} A_{13}$$

$$= 2(5) + 1(-7) + 3(11)$$

$$= 36 \quad (\text{same result})$$

© 2010 Pearson Education, Inc., Upper Saddle River, NJ. All rights reserved. This material is protected under all copyright laws as they currently exist. No portion of this material may be reproduced, in any form or by any means, without permission in writing from the publisher.

4-42. Determine the resultant moment produced by forces F_B and F_C about point O . Express the result as a Cartesian vector.

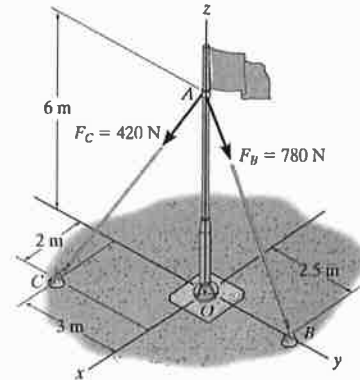

Position Vector and Force Vectors: The position vector r_{OA} and force vectors F_B and F_C , Fig. a, must be determined first.

$$r_{OA} = [6\mathbf{k}] \text{ m}$$

$$F_B = F_B u_{FB} = 780 \left[\frac{(0-0)\mathbf{i} + (2.5-0)\mathbf{j} + (0-6)\mathbf{k}}{\sqrt{(0-0)^2 + (2.5-0)^2 + (0-6)^2}} \right] = [300\mathbf{j} - 720\mathbf{k}] \text{ N}$$

$$F_C = F_C u_{FC} = 420 \left[\frac{(2-0)\mathbf{i} + (-3-0)\mathbf{j} + (0-6)\mathbf{k}}{\sqrt{(2-0)^2 + (-3-0)^2 + (0-6)^2}} \right] = [120\mathbf{i} - 180\mathbf{j} - 360\mathbf{k}] \text{ N}$$

Resultant Moment: The resultant moment of F_B and F_C about point O is given by

$$M_O = r_{OA} \times F_B + r_{OA} \times F_C$$

$$M = \begin{vmatrix} \mathbf{i} & \mathbf{j} & \mathbf{k} \\ 0 & 0 & 6 \\ 0 & 300 & -720 \end{vmatrix} + \begin{vmatrix} \mathbf{i} & \mathbf{j} & \mathbf{k} \\ 0 & 0 & 6 \\ 120 & -180 & -360 \end{vmatrix}$$

$$= [-720\mathbf{i} + 720\mathbf{j}] \text{ N}\cdot\text{m} \quad \text{Ans}$$

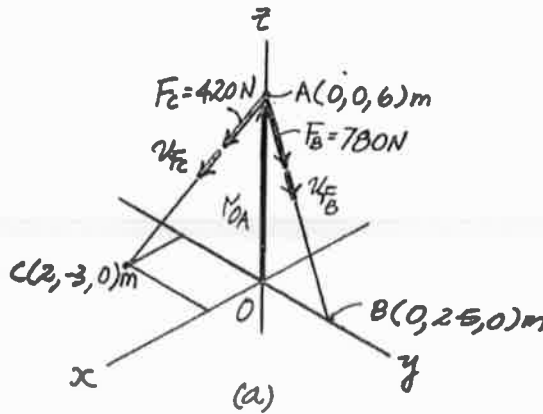

Brief:

$$\vec{M}_O = \vec{r}_{OA} \times \vec{F}_B + \vec{r}_{OA} \times \vec{F}_C$$

$$\vec{F}_B = F_B \vec{u}_{AB} \quad , \quad \vec{F}_C = F_C \vec{u}_{AC}$$

© 2010 Pearson Education, Inc., Upper Saddle River, NJ. All rights reserved. This material is protected under all copyright laws as they currently exist. No portion of this material may be reproduced, in any form or by any means, without permission in writing from the publisher.

4-55. Determine the moment of the force F about an axis extending between A and C . Express the result as a Cartesian vector.

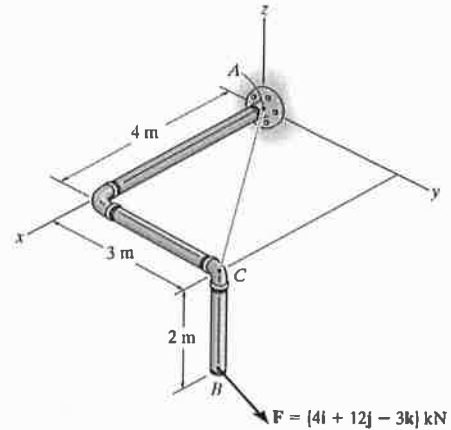

Position Vector:

$$r_{CB} = [-2k] \text{ m}$$

Unit Vector Along AC Axis:

$$u_{AC} = \frac{(4-0)i + (3-0)j}{\sqrt{(4-0)^2 + (3-0)^2}} = 0.8i + 0.6j$$

Moment of Force F About AC Axis: With $F = [4i + 12j - 3k]$ kN applying Eq. 4-7, we have

$$M_{AC} = u_{AC} \cdot (r_{CB} \times F)$$

$$= \begin{vmatrix} 0.8 & 0.6 & 0 \\ 0 & 0 & -2 \\ 4 & 12 & -3 \end{vmatrix}$$

$$= 0.8[(0)(-3) - 12(-2)] - 0.6[0(-3) - 4(-2)] + 0$$

$$= 14.4 \text{ kN} \cdot \text{m}$$

Expressing M_{AC} as a Cartesian vector yields

$$M_{AC} = M_{AC} u_{AC}$$

$$= 14.4(0.8i + 0.6j)$$

$$= [11.5i + 8.64j] \text{ kN} \cdot \text{m}$$

Ans

Brief:

$$M_{AC} = \vec{u}_{AC} \cdot (\vec{r}_{CB} \times F) =$$

$$\begin{vmatrix} u_{ACx} & u_{ACy} & u_{ACz} \\ r_{CBx} & r_{CBy} & r_{CBz} \\ F_x & F_y & F_z \end{vmatrix}$$

$$\vec{u}_{AC} = \frac{\vec{r}_{AC}}{r_{AC}}$$

Note: C is a point on AC line [same as O]

67

EQUILIBRIUM

When a system of forces acting on a body has no resultant, the body is in equilibrium.

The equilibrium means that the body remains in stability for both rest and moving states in first Newton's law.

Here, we will study the static equilibrium.

According to the Newton's first law, the equations of equilibrium for the rigid body in the plane are:

$$\sum F_x = 0$$

$$\sum F_y = 0$$

$$\sum M_o = 0$$

where o is any point in the plane.

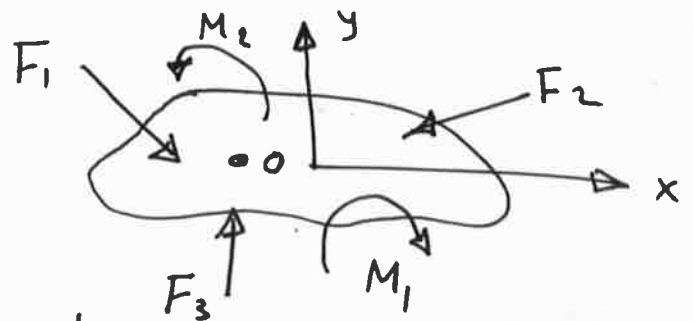

Free Body Diagram (FBD):









FBD is a sketch of a body or a portion of a body completely isolated (or free) from its surroundings.

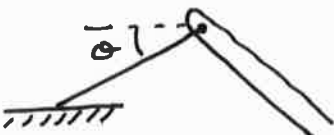

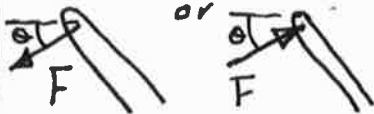

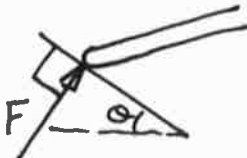

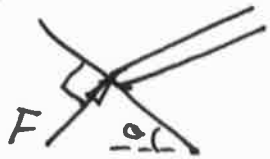
By using FBD, the unknown forces and moments acting on a body can be determined by the three equations of equilibrium.

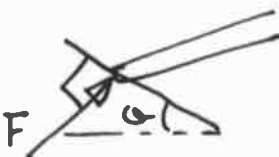
We need to know three things before studying how to draw the FBD:

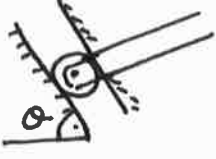
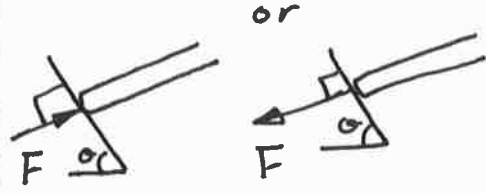
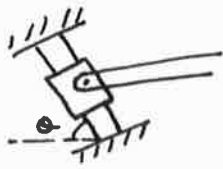
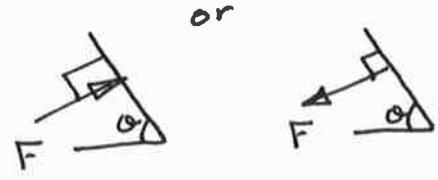
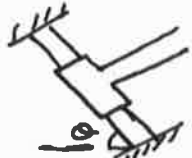
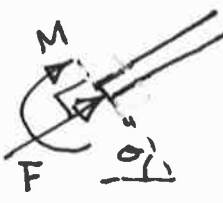
① Support Reactions :

There are various types of reactions that occur at supports and points of support between bodies subjected to forces.

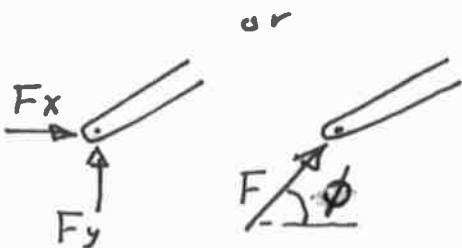
Type of Connection	Reaction	No. of unknowns
① Cable 		one (tension force)
② Link 		one (tension or compression)
③ Roller 		one (reaction acting perpendicular to the surface at the point of contact).
④ Rocker 		" " "
⑤ Smooth contacting surface 		" " "

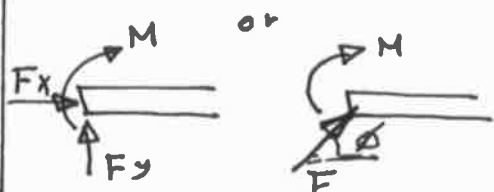
Type of Connection	Reaction	No. of unknowns
<p>⑥ Roller on confined slot.</p> 		<p>one (reaction acting perpendicular to the surface at the point of contact)</p>
<p>⑦ Member pin connected to collar on smooth rod.</p> 		<p>one (" " " " " " " " " ")</p>
<p>⑧ Member fixed connected to collar on smooth rod.</p> 		<p>Two (force and moment at the junction point)</p>
<p>⑨ Slider (or roller guide).</p> 		<p>Two (" " " ")</p>
<p>⑩ Pin (or hinge support).</p> 		<p>Two (components of force or magnitude and direction of resultant force).</p>
<p>⑪ Fixed support</p> 		<p>Three (two components of force and moment or resultant force and moment).</p>

② External and Internal Forces :

Since a rigid body is a composition of particles, both external and internal loadings may act on it. Only the external loadings are represented on FBD because the net effect of internal forces on the body is zero.

③ Weight of a Body :

When a body is subjected to a gravitational field then it has a specified weight. The weight of the body is represented by a resultant force directed downward and located at the center of gravity of the body. Remember $W = m * g$.

Procedure for Drawing the FBD:

- 1- Isolate the body from its constraints and connections and draw its outlined shape.
2. Identify all the external forces and moments that act on the body. These are generally due to:
 - (1) Applied loadings.
 - (2) Reactions at the supports or at the points of contact with other bodies.
 - (3) The weight of the body.

Ex.1: Draw FBD for the beam with mass 100 kg.

sol. $W = m \times g = 100 \times 9.81$
 $= 981 \text{ N}$

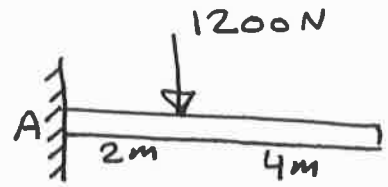

The FBD is :

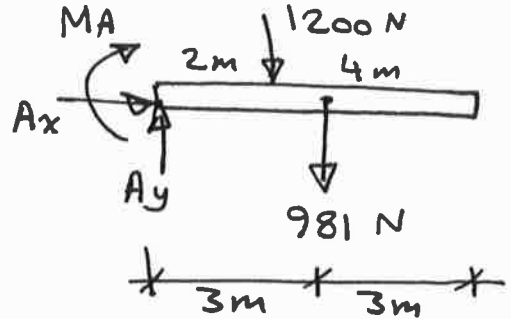

Ex.2: Draw FBD for the frame.

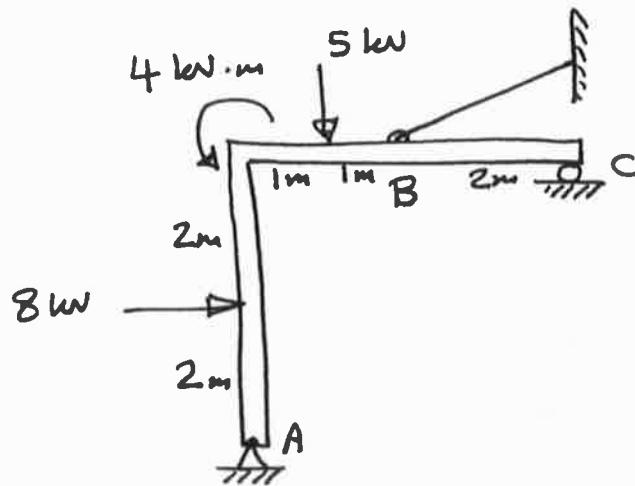

sol. FBD is shown below:

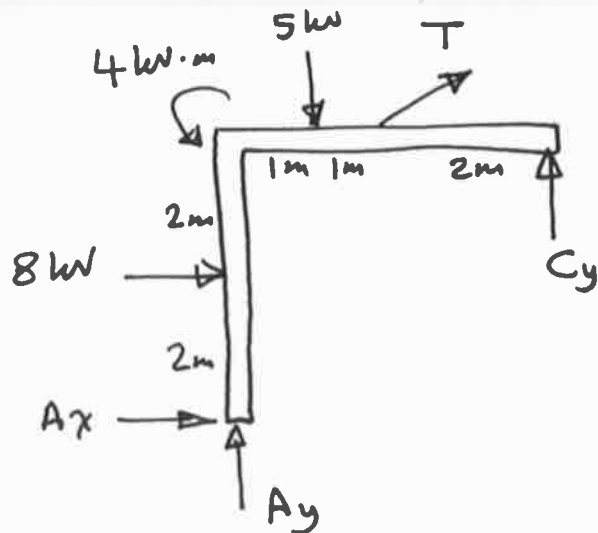

Ex.3: Two smooth tubes A & B, each having mass of 2 kg rest between the inclined plates. Draw FBD for tube A, tube B, and tube A & B together.

Sol.

$$W_A = W_B = 2 \times 9.81 = 19.62 \text{ N}$$

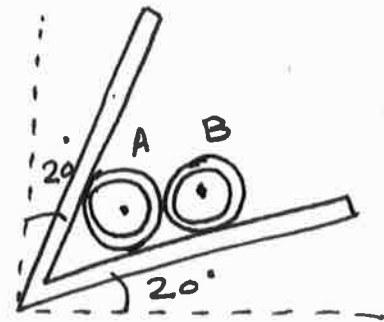

FBD tube A

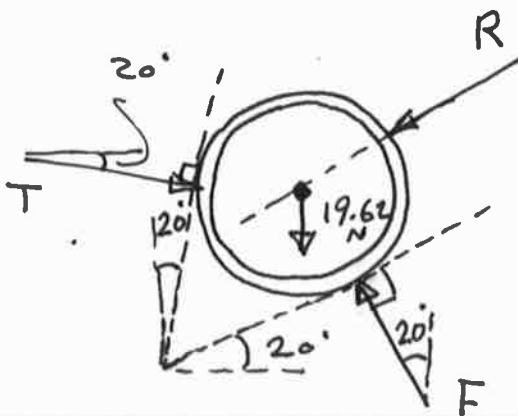

FBD tube B

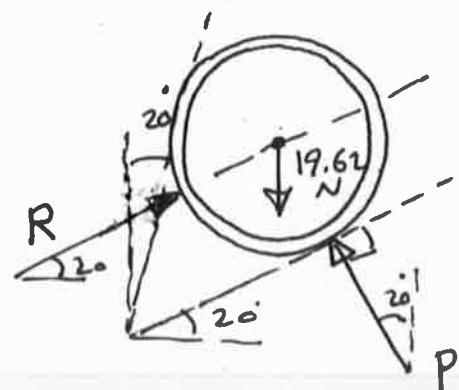

FBD for A & B together

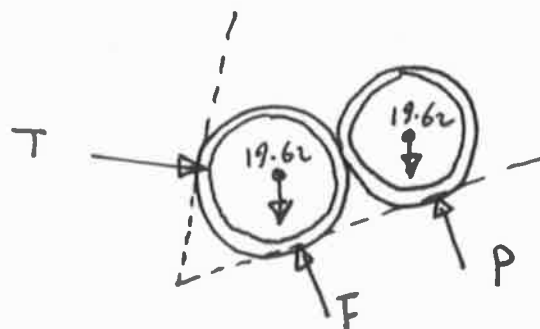

Here, R not drawn because it internal force. (R in FBD A and FBD B cancel each other).

Ex.4: Draw FBD for the member ABC.

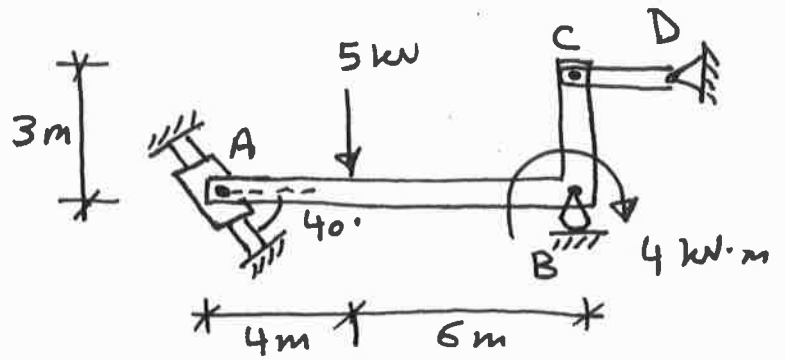

Sol.

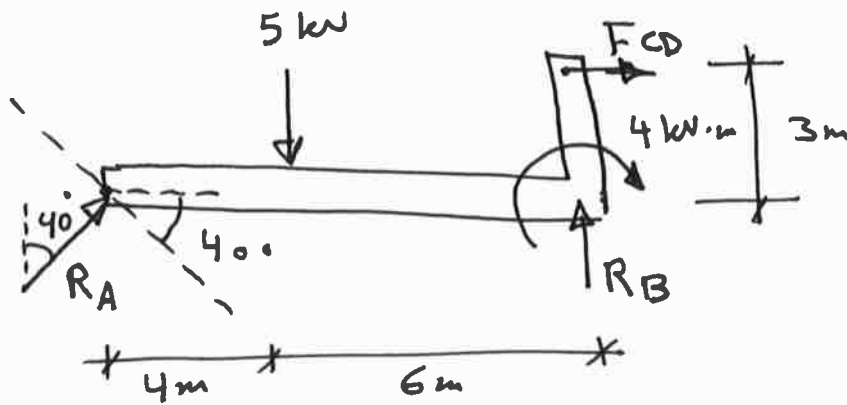

Ex.5: Draw FBD for the uniform bar which has a mass of 100 kg and a center of mass G. The supports A, B, and C are smooth.

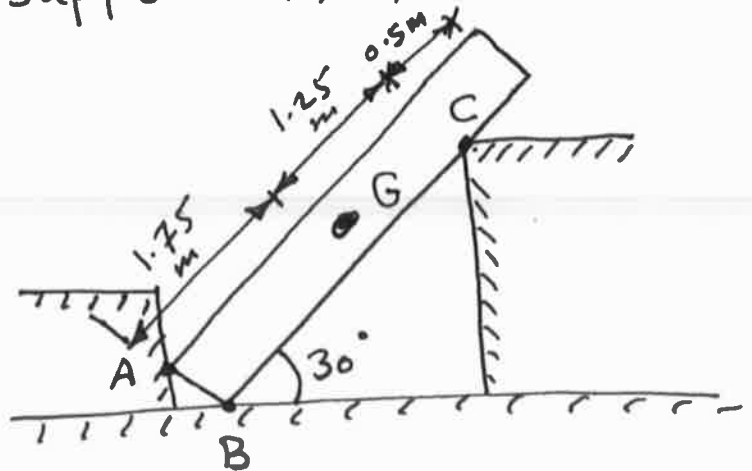

Sol. $W = 100 \times 9.81$
 $= 981 \text{ N}$

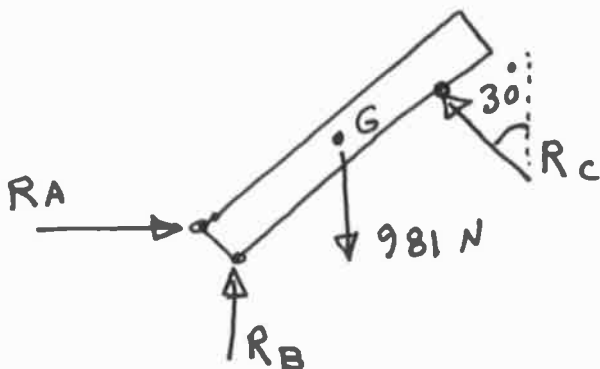

Springs: If we have a linearly elastic spring, (linear means that the change in length is proportional to the applied force, and elastic means that the spring will return to its original shape after the applied force is removed).

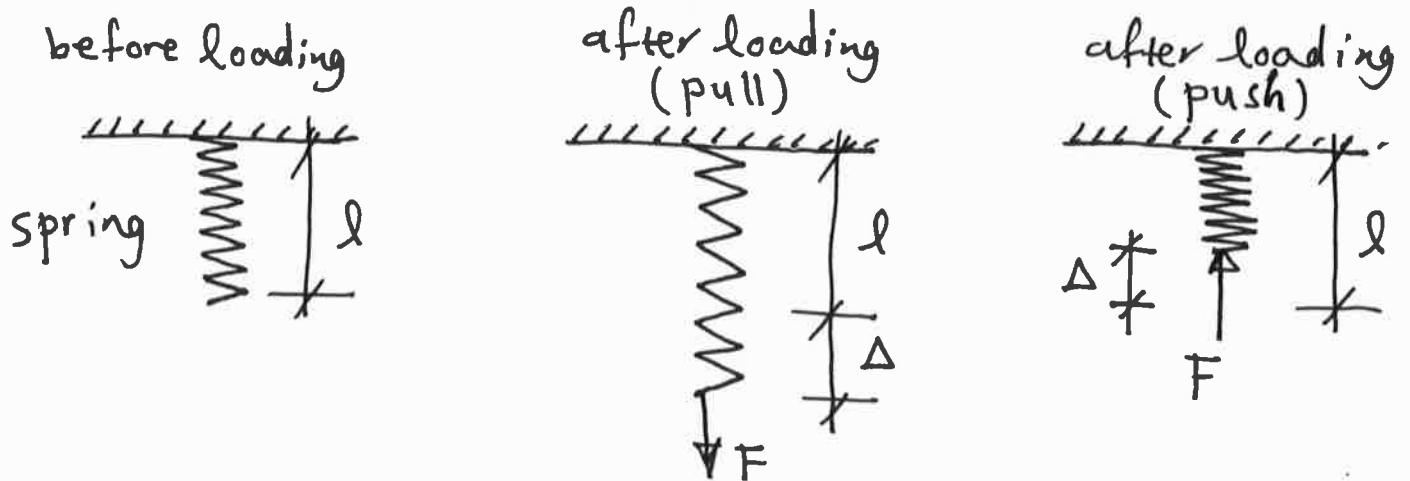

l : original length of the spring.

Δ : change in length after loading (elongation or shortening)

Each spring has a stiffness called spring constant or spring stiffness, denoted by (k), and defined as a force needed to cause a unit length of change in the original spring length. The units of k are (N/m , kN/m , lb/in , ... etc.)

The magnitude of the force exerted on a spring which has a stiffness k is:

$$F = k \cdot \Delta$$

For example, if $k = 500 N/m$, then the force needed to change the length of the spring by $0.2 m$ is:

$$F = k \cdot \Delta = 500 \frac{N}{m} \times 0.2 m = 100 N$$

The Problems of Equilibrium of Coplanar Forces:

The following two examples illustrate these problems.

Ex.1: Determine the tension in cables BA and BC necessary to support the 60-kg cylinder.

Solution:

$$W_{\text{cylinder}} = 60 \times 9.81 \\ = 588.6 \text{ N}$$

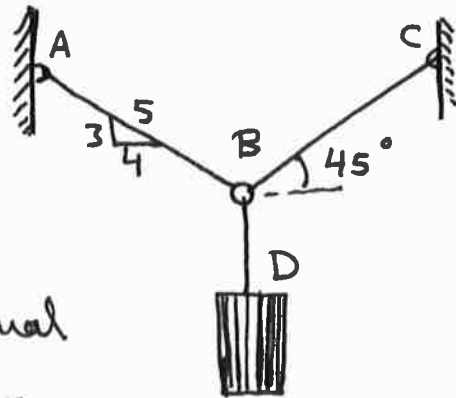

The tension in cable BD is equal to the weight of the cylinder

$$\Rightarrow T_{BD} = 588.6 \text{ N}$$

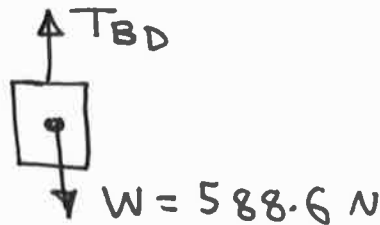

To find T_{BC} and T_{BA} , draw the FBD for the ring B, and apply $\Sigma F_x = 0$ & $\Sigma F_y = 0$ at the ring B.

$$\rightarrow \Sigma F_x = 0$$

$$T_{BC} \cos 45 - \frac{4}{5} T_{BA} = 0 \quad \text{--- ①}$$

$$\uparrow \Sigma F_y = 0$$

$$T_{BC} \sin 45 + \frac{3}{5} T_{BA} - 588.6 = 0 \quad \text{--- ②}$$

$$\text{solve ① \& ②} \Rightarrow T_{BC} = 475.66 \text{ N}$$

$$\text{and } T_{BA} = 420 \text{ N}$$

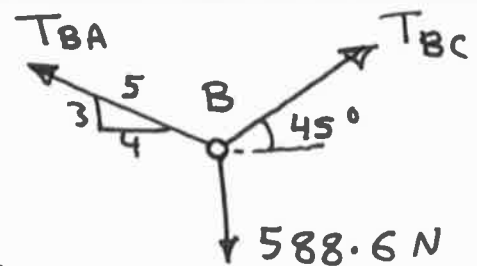

Ex.2: The unstretched length of spring AB is 3m. If the block is held in the equilibrium position, determine the mass of the block.

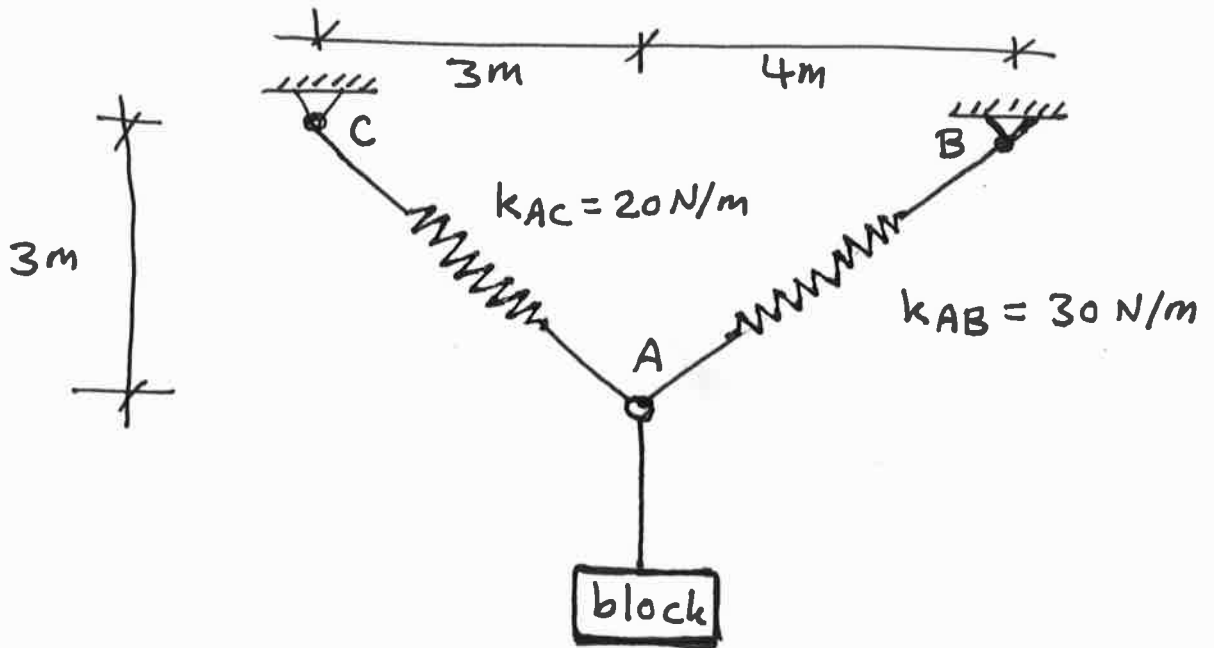

Solution: $F = k \cdot \Delta \Rightarrow T_{AB} = 30(5-3) = 60 \text{ N}$

FBD (ring A):

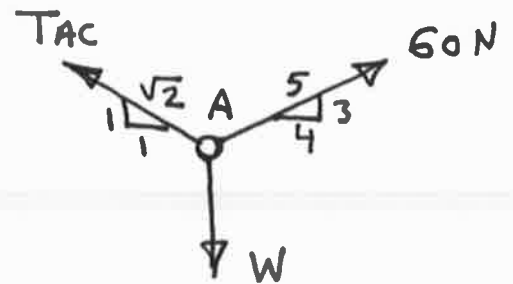

$$\rightarrow \Sigma F_x = 0$$

$$60\left(\frac{4}{5}\right) - T_{AC}\left(\frac{1}{\sqrt{2}}\right) = 0$$

$$\Rightarrow T_{AC} = 67.88 \text{ N}$$

$$\uparrow \Sigma F_y = 0 \Rightarrow -W + 60\left(\frac{3}{5}\right) + 67.88\left(\frac{1}{\sqrt{2}}\right) = 0$$

$$\Rightarrow W = 84 \text{ N}$$

$$W = m \cdot g \Rightarrow \text{the mass of block} = \frac{W}{g} = \frac{84}{9.81} = \boxed{8.56 \text{ kg}}$$

Solving the Equilibrium Problems:

To find the unknowns in the structure, the FBD and the equations of equilibrium are used.

Examples:

Ex.1: Determine the reactions at A and B. Neglect the weight of the beam.

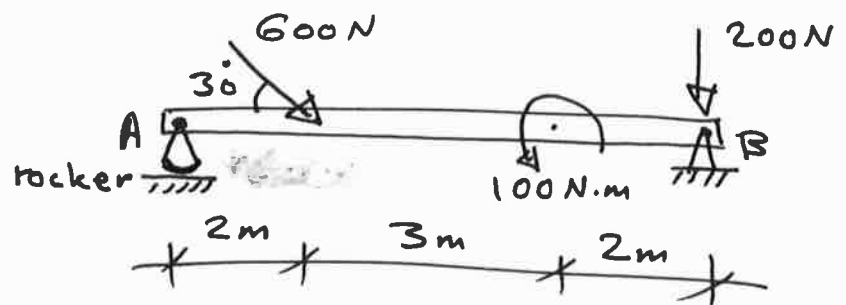

Sol.

$$\rightarrow \sum F_x = 0$$

$$600 \cos 30 - B_x = 0$$

$$\Rightarrow B_x = 519.61 \text{ N} \leftarrow$$

$$\curvearrow \sum M_B = 0$$

$$A_y(7) - 600 \sin 30(5) - 100 = 0$$

$$\Rightarrow A_y = 228.57 \text{ N} \uparrow$$

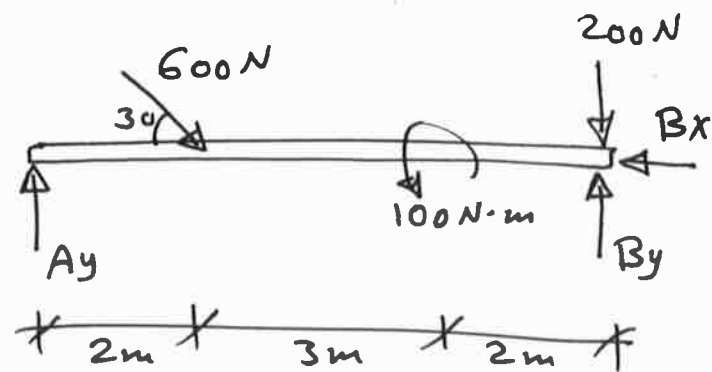

FBD

$$\uparrow \sum F_y = 0$$

$$A_y + B_y - 600 \sin 30 - 200 = 0$$

$$228.57 + B_y - 600 \sin 30 - 200 = 0 \Rightarrow B_y = 271.43 \text{ N} \uparrow$$

Ex.2: Determine the tension in the cord (that wraps over frictionless pulley), and the reactions at pin A.

Sol. First draw FBD.
The FBD for the cord and pulley is combined in one diagram (the forces in contacting portions are internal forces).

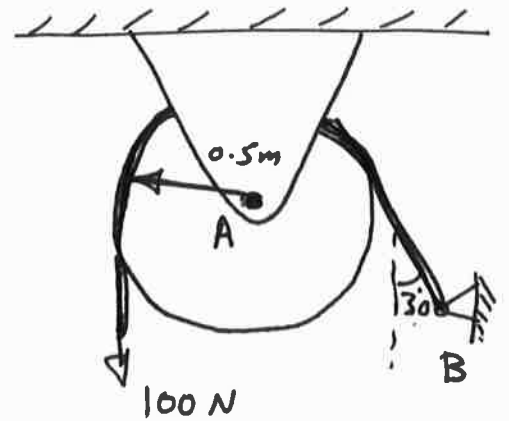

$$\curvearrowright + \Sigma M_A = 0$$

$$T(0.5) - 100(0.5) = 0$$

$$\Rightarrow T = 100 \text{ N}$$

Note: The tension remains constant as the cord passes over the pulley for any radius and any angle.

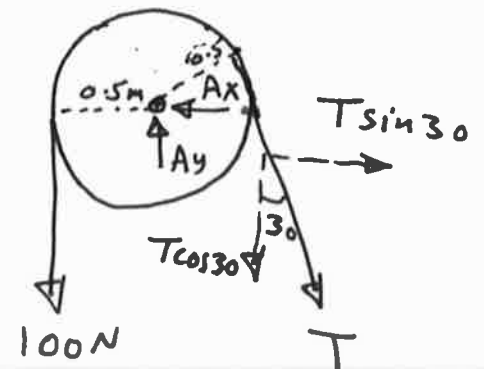

FBD

$$\rightarrow + \Sigma F_x = 0$$

$$-A_x + 100 \sin 30 = 0 \Rightarrow A_x = 50 \text{ N} \leftarrow$$

$$\uparrow + \Sigma F_y = 0$$

$$A_y - 100 - 100 \cos 30 = 0 \Rightarrow A_y = 186.6 \text{ N} \uparrow$$

Ex.3 Determine the tension in the cable and the reaction at A.

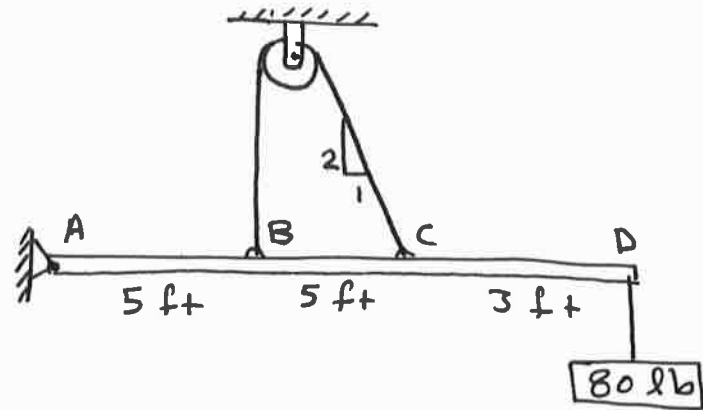

Sol.

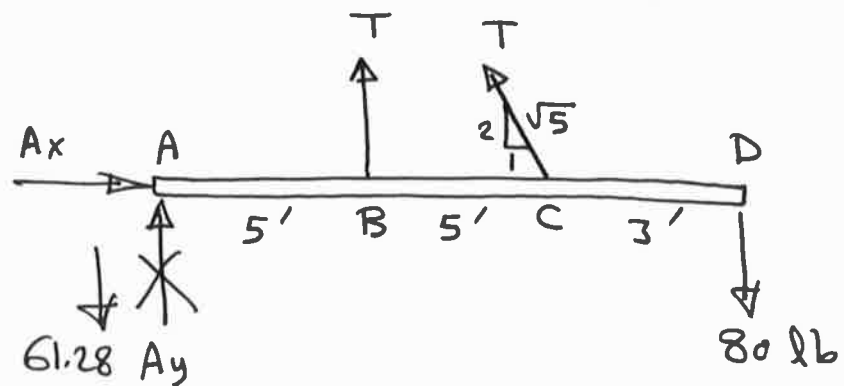

$$\curvearrowright + \Sigma M_A = 0$$

$$-T(5) - T\left(\frac{2}{\sqrt{5}}\right)(10) + 80(13) = 0$$

$$\Rightarrow T = 74.58 \text{ lb}$$

$$\rightarrow + \Sigma F_x = 0$$

$$A_x - 74.58\left(\frac{1}{\sqrt{5}}\right) = 0 \Rightarrow A_x = 33.35 \text{ lb} \rightarrow$$

$$\uparrow + \Sigma F_y = 0$$

$$A_y + 74.58 + 74.58\left(\frac{2}{\sqrt{5}}\right) - 80 = 0$$

$$\Rightarrow A_y = -61.28 = 61.28 \text{ lb} \downarrow$$

(80)

The Resultant of the Distributed Loadings:

The body may be subjected to distributed loadings such as those caused by wind, fluids, or weight of material over the body's surface.

The most common types of these loads are the uniform loading and triangular loading.

① Uniform loading:

The magnitude of the resultant is $R = w \times l$
or (area of load).

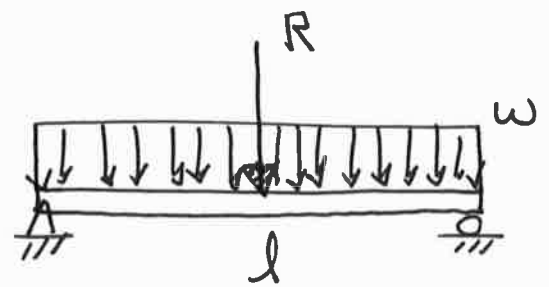

The location of R passes through the centroid of the rectangle (middle of the rectangle).

For example:

$$R = 5 \times 4 = 20 \text{ kN}$$

located at 2m from B.

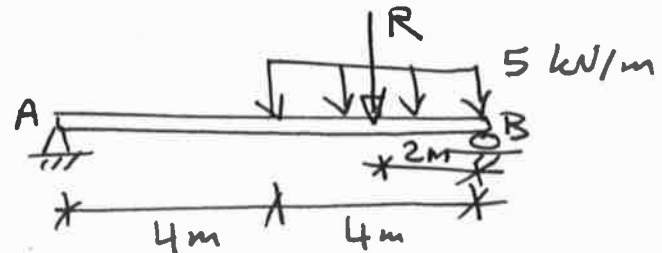

② Triangular loading:

The resultant R is the area of triangle, or:

$$R = \frac{wl}{2}, \text{ located at}$$

the centroid of triangle (one third the length of the triangle measured from the right side).

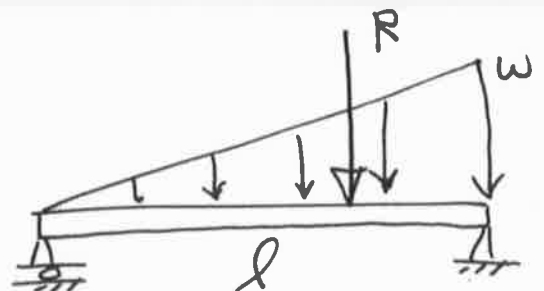

For example: $R = \frac{5 \times 3}{2} = 7.5 \text{ kN}$
 located at 1m from B

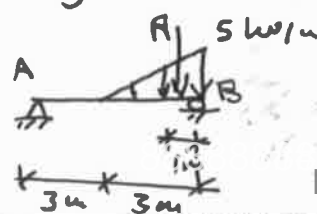

Ex.1 Determine the reactions at A & B.

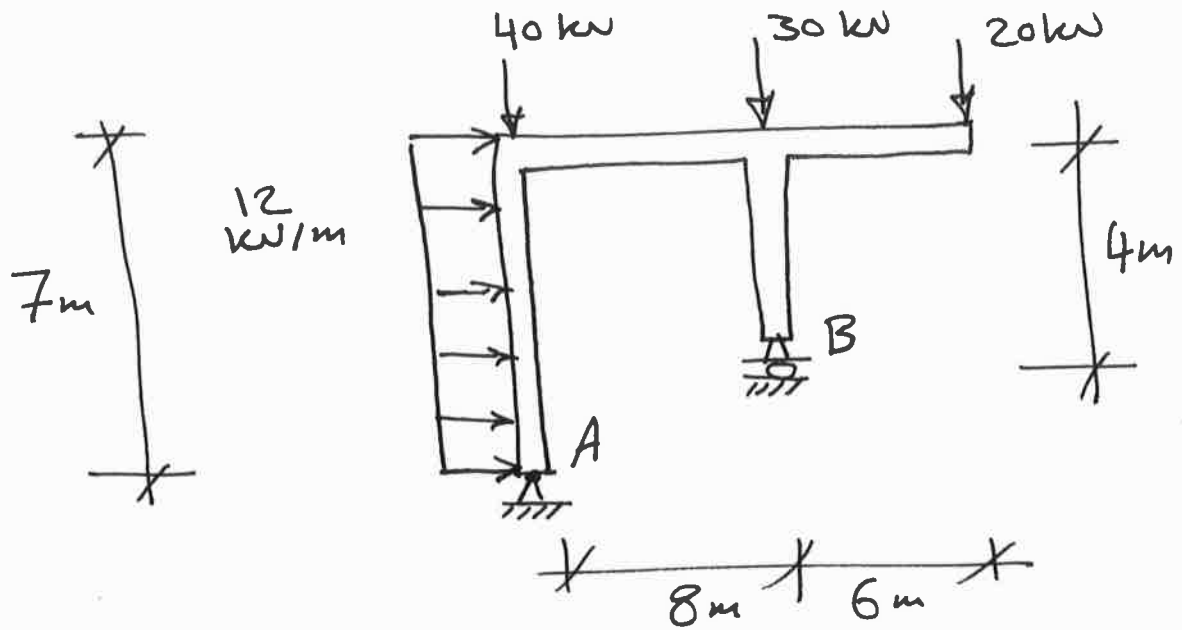

Sol.

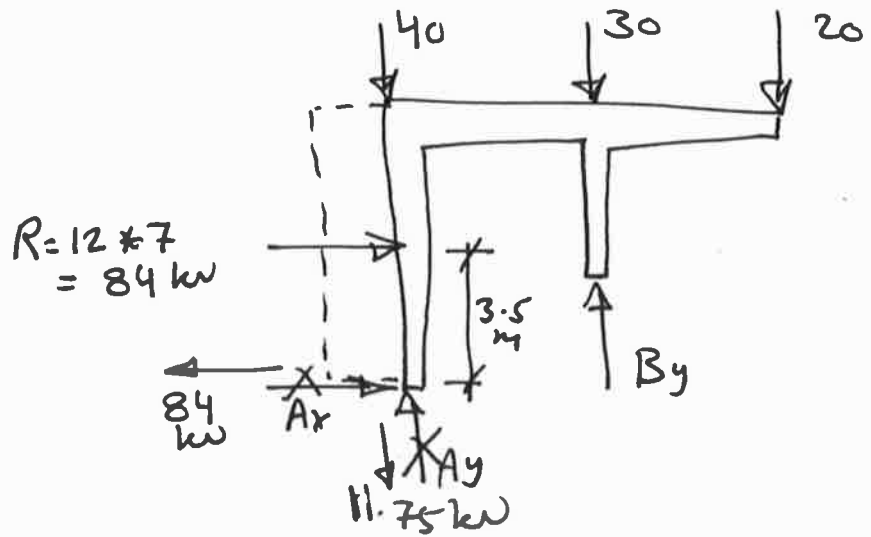

$$\curvearrowright + \sum M_A = 0$$

$$20(14) + 30(8) + 84(3.5) - B_y(8) = 0 \Rightarrow B_y = 101.75 \text{ kN} \uparrow$$

$$\uparrow + \sum F_y = 0$$

$$A_y + 101.75 - 40 - 30 - 20 = 0 \Rightarrow A_y = -11.75 \Rightarrow A_y = 11.75 \text{ kN} \downarrow$$

$$\rightarrow + \sum F_x = 0$$

$$A_x + 84 = 0 \Rightarrow A_x = -84 \Rightarrow A_x = 84 \text{ kN} \leftarrow$$

Ex.2: Determine the reactions at A & B.

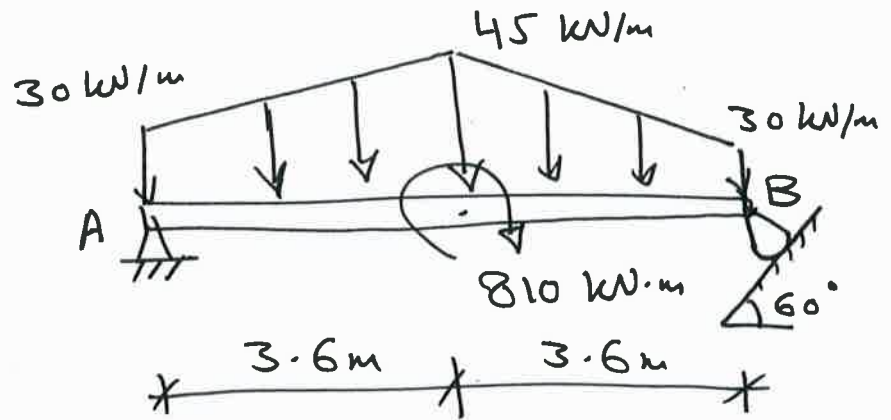

Sol.

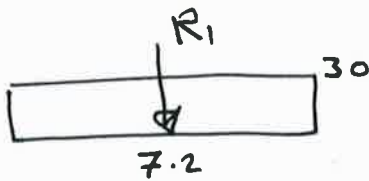

$$R_1 = 30 \times 7.2 = 216 \text{ kN}$$

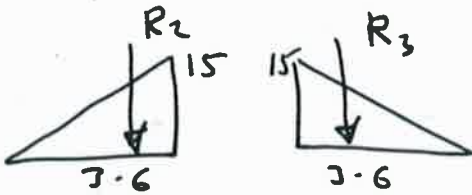

$$R_2 = \frac{15 \times 3.6}{2} = 27 \text{ kN}$$

$$R_3 = \frac{15 \times 3.6}{2} = 27 \text{ kN}$$

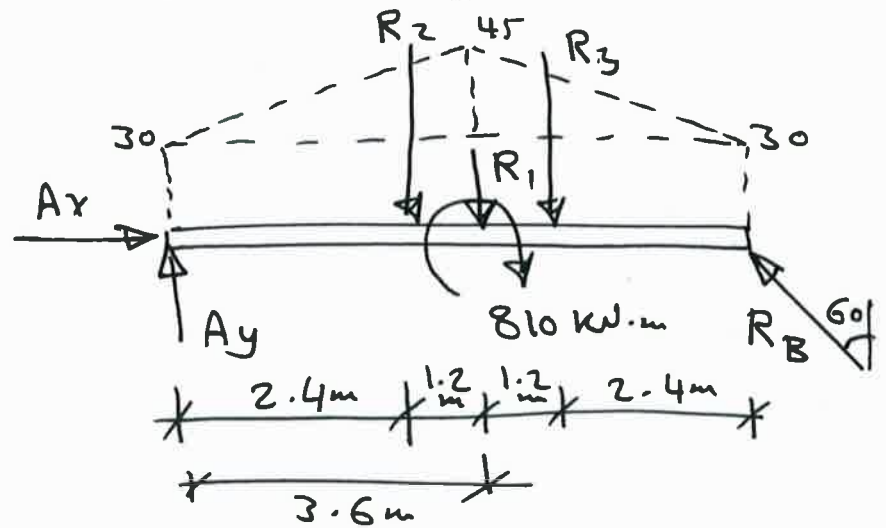

$$\sum M_A = 0$$

$$27(2.4) + 216(3.6) + 810 + 27(4.8) - R_B \cos 60(7.2) = 0$$

$$\Rightarrow R_B = 495 \text{ kN}$$

$$[\text{or : } 270(3.6) + 810 - R_B \cos 60(7.2) = 0 \quad \text{where } 270 = 216 + 27 + 27]$$

$$\sum F_x = 0 : Ax - 495 \sin 60 = 0 \Rightarrow Ax = 428.68 \text{ kN} \rightarrow$$









$$\sum F_y = 0 : Ay - 27 - 216 - 27 + 495 \cos 60 = 0$$

$$\Rightarrow Ay = 22.5 \text{ kN} \uparrow$$

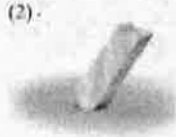



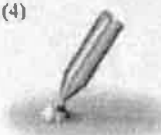
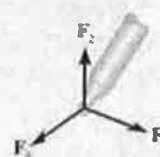

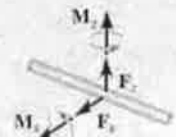

Equilibrium in Three Dimensions:

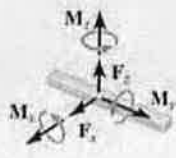
① Support reactions in 3D systems:

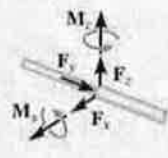
TABLE 5-2 Supports for Rigid Bodies Subjected to Three-Dimensional Force Systems.

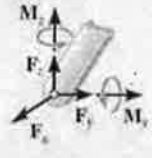
Types of Connection	Reaction	Number of Unknowns
(1)  cable		One unknown. The reaction is a force which acts away from the member in the known direction of the cable.
(2)  smooth surface support		One unknown. The reaction is a force which acts perpendicular to the surface at the point of contact.
(3)  roller		One unknown. The reaction is a force which acts perpendicular to the surface at the point of contact.
(4)  ball and socket		Three unknowns. The reactions are three rectangular force components.
(5)  single journal bearing		Four unknowns. The reactions are two force and two couple-moment components which act perpendicular to the shaft. Note: The couple moments are generally not applied if the body is supported elsewhere. See the examples.

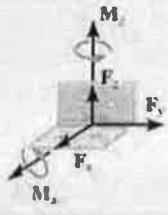
continued

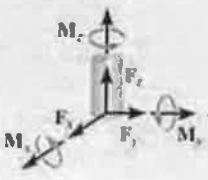
TABLE 5-2 Continued		
Types of Connection	Reaction	Number of Unknowns
(6)  single journal bearing with square shaft		Five unknowns. The reactions are two force and three couple-moment components. <i>Note:</i> The couple moments are generally not applied if the body is supported elsewhere. See the examples.
(7)  single thrust bearing		Five unknowns. The reactions are three force and two couple-moment components. <i>Note:</i> The couple moments are generally not applied if the body is supported elsewhere. See the examples.
(8)  single smooth pin		Five unknowns. The reactions are three force and two couple-moment components. <i>Note:</i> The couple moments are generally not applied if the body is supported elsewhere. See the examples.
(9)  single hinge		Five unknowns. The reactions are three force and two couple-moment components. <i>Note:</i> The couple moments are generally not applied if the body is supported elsewhere. See the examples.
(10)  fixed support		Six unknowns. The reactions are three force and three couple-moment components.

Typical examples of actual supports that are referenced to Table 5-2 are shown in the following sequence of photos.



This ball-and-socket joint provides a connection for the housing of an earth grader to its frame. (4)

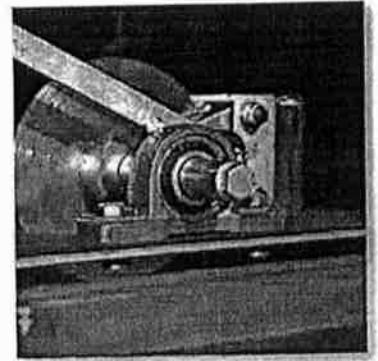

This journal bearing supports the end of the shaft. (5)

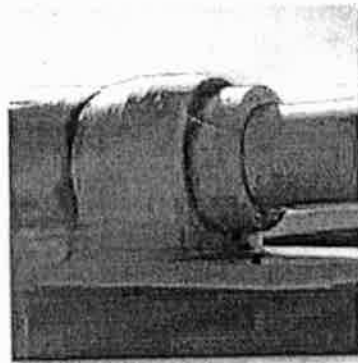

This thrust bearing is used to support the drive shaft on a machine. (7)

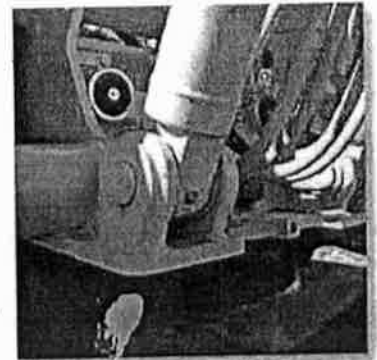

This pin is used to support the end of the strut used on a tractor. (8)

② Equations of equilibrium in 3D:

In Cartesian vectors: $\sum \vec{F} = 0 \quad \forall \quad \sum \vec{M}_O = 0$

in which $\sum \vec{F} = \sum F_x i + \sum F_y j + \sum F_z k$

and $\sum \vec{M}_O = \sum M_x i + \sum M_y j + \sum M_z k$

In scalar: $\sum F_x = 0, \quad \sum F_y = 0, \quad \sum F_z = 0$
 $\sum M_x = 0, \quad \sum M_y = 0, \quad \sum M_z = 0$

Ex.1: The boom is used to support the 375-N flowerpot. Determine the tension developed in wires AB and AC.

Solution:

FBD (boom):

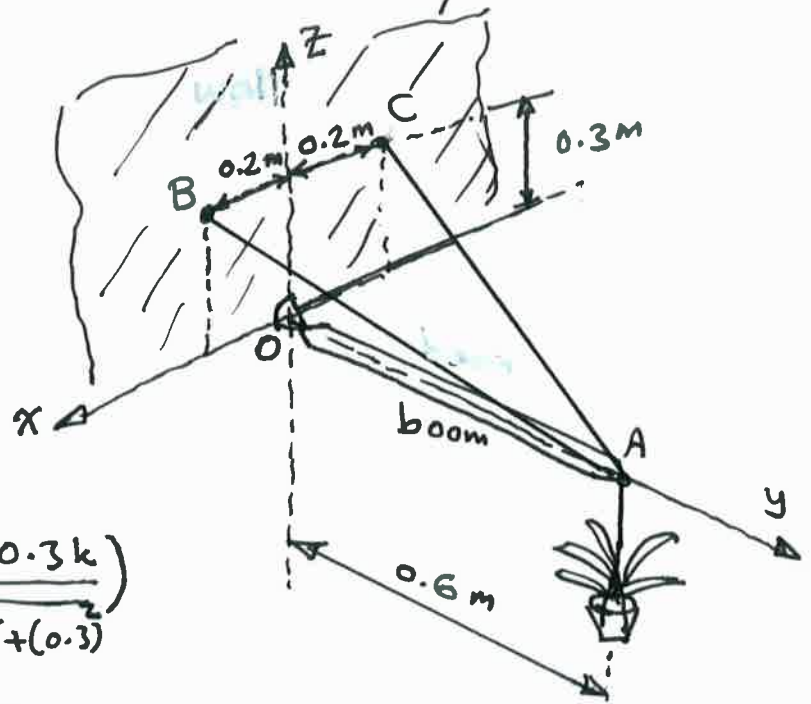

$$\vec{F}_{AB} = F_{AB} \frac{\vec{r}_{AB}}{r_{AB}}$$

$$= F_{AB} \left(\frac{0.2\mathbf{i} - 0.6\mathbf{j} + 0.3\mathbf{k}}{\sqrt{(0.2)^2 + (-0.6)^2 + (0.3)^2}} \right)$$

$$= \frac{2}{7} F_{AB} \mathbf{i} - \frac{6}{7} F_{AB} \mathbf{j} + \frac{3}{7} F_{AB} \mathbf{k}$$

$$\vec{F}_{AC} = F_{AC} \frac{\vec{r}_{AC}}{r_{AC}}$$

$$= -\frac{2}{7} F_{AC} \mathbf{i} - \frac{6}{7} F_{AC} \mathbf{j} + \frac{3}{7} F_{AC} \mathbf{k}$$

$$\sum \vec{M}_O = 0$$

$$\Rightarrow \vec{r}_{OA} \times (\vec{F}_{AB} + \vec{F}_{AC} + \vec{W}) = 0$$

$$\Rightarrow (0.6\mathbf{j}) \times \left[\left(\frac{2}{7} F_{AB} \mathbf{i} - \frac{6}{7} F_{AB} \mathbf{j} + \frac{3}{7} F_{AB} \mathbf{k} \right) \right.$$

$$\left. + \left(-\frac{2}{7} F_{AC} \mathbf{i} - \frac{6}{7} F_{AC} \mathbf{j} + \frac{3}{7} F_{AC} \mathbf{k} \right) + (-375\mathbf{k}) \right] = 0$$

$$\sum M_x = 0 \Rightarrow \frac{18}{7} F_{AB} + \frac{18}{7} F_{AC} - 2250 = 0 \quad \text{--- ①}$$

$$\sum M_y = 0 \Rightarrow 0 = 0$$

$$\sum M_z = 0 \Rightarrow -\frac{12}{7} F_{AB} + \frac{12}{7} F_{AC} = 0 \quad \text{--- ②}$$

Solve ① & ② \Rightarrow $F_{AB} = F_{AC} = 437.5 \text{ N}$

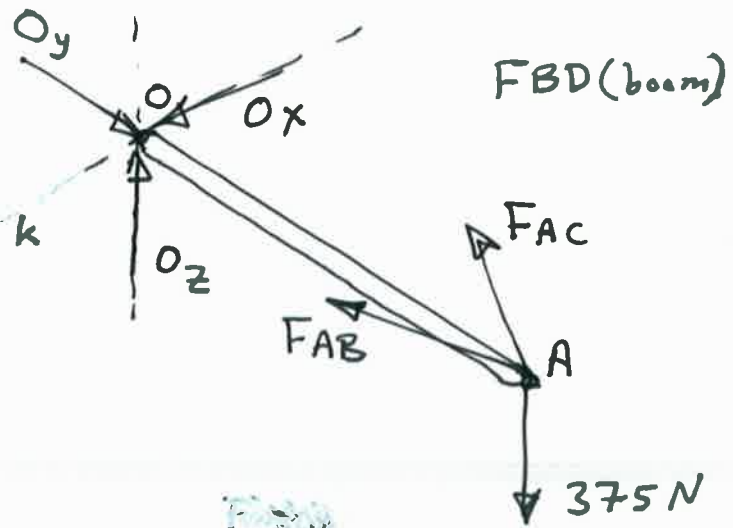

Ex. 2 :

The force exerted on the highway sign by wind and the sign's weight is $F = 800i - 600j$ (N). Determine the reactions at the built-in support at O .

Solution: The force acting on the sign is

$$F = F_x i + F_y j + F_z k = 800i - 600j + 0k \text{ N,}$$

and the position from O to the point on the sign where F acts is

$$r = 0j + 8j + 8k \text{ m.}$$

The force equations of equilibrium for the sign are

$$O_x + F_x = 0,$$

$$O_y + F_y = 0,$$

$$\text{and } O_z + F_z = 0.$$

Note that the weight of the sign is included in the components of F .

The moment equation, in vector form, is

$$\sum M = M_O + r \times F.$$

Expanded, we get

$$\sum M = M_{Ox}i + M_{Oy}j + M_{Oz}k + \begin{vmatrix} i & j & k \\ 0 & 8 & 8 \\ 800 & -600 & 0 \end{vmatrix} = 0.$$

The corresponding scalar equations are

$$M_{Ox} - (8)(-600) = 0,$$

$$M_{Oy} + (8)(800) = 0,$$

$$\text{and } M_{Oz} - (8)(800) = 0.$$

Solving for the support reactions, we get

$$O_x = -800 \text{ N,}$$

$$O_y = 600 \text{ N,}$$

$$O_z = 0,$$

$$M_{Ox} = -4800 \text{ N-m,}$$

$$M_{Oy} = -6400 \text{ N-m,}$$

$$\text{and } M_{Oz} = 6400 \text{ N-m.}$$

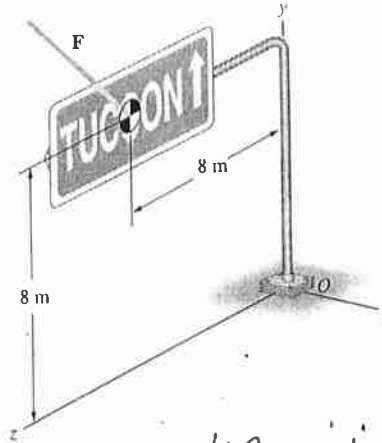

$$4800i + 6400j - 6400k$$

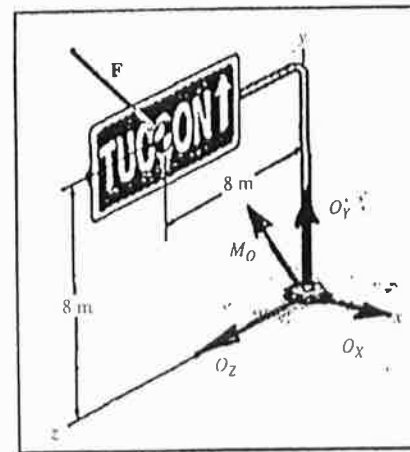

Or To find the reaction forces:

$$\sum \vec{F} = 0 \Rightarrow (800i - 600j + 0k) + (O_x i + O_y j + O_z k)$$

$$\Rightarrow (800 + O_x)i + (-600 + O_y)j + (0 + O_z)k = 0$$

$$\sum F_x i = (800 + O_x)i, \sum F_x = 0 \Rightarrow 800 + O_x = 0$$

$$\Rightarrow O_x = -800 \text{ N}$$

$$\sum F_y j = (-600 + O_y)j, \sum F_y = 0 \Rightarrow O_y = 600 \text{ N}$$

$$\sum F_z k = (0 + O_z)k, \sum F_z = 0 \Rightarrow O_z = 0$$

Ex. 3:

The tower is 70 m tall. The tension in each cable is 2 kN. Treat the base of the tower A as a built-in support. What are the reactions at A ?

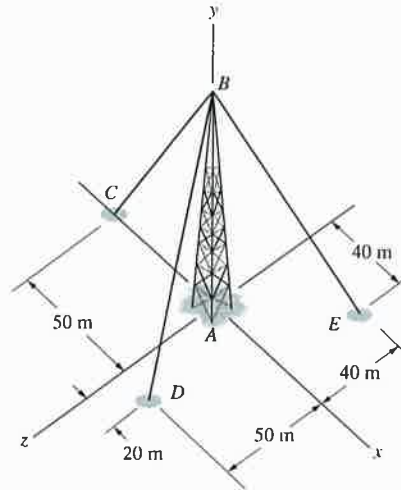

Solution: The strategy is to determine moments about A due to the cables. This requires the unit vectors parallel to the cables. The coordinates of the points are:

$$A(0, 0, 0), B(0, 70, 0), C(-50, 0, 0),$$

$$D(20, 0, 50), E(40, 0, -40).$$

The unit vectors parallel to the cables, directed from B to the points $E, D,$ and C

$$\mathbf{r}_{BE} = 40\mathbf{i} - 70\mathbf{j} - 40\mathbf{k},$$

$$\mathbf{r}_{BD} = 20\mathbf{i} - 70\mathbf{j} + 50\mathbf{k},$$

$$\mathbf{r}_{BC} = -50\mathbf{i} - 70\mathbf{j}.$$

The unit vectors parallel to the cables, pointing from B , are:

$$\mathbf{u}_{BE} = 0.4444\mathbf{i} - 0.7778\mathbf{j} - 0.4444\mathbf{k},$$

$$\mathbf{u}_{BD} = 0.2265\mathbf{i} - 0.7926\mathbf{j} + 0.5661\mathbf{k},$$

$$\mathbf{u}_{BC} = -0.5812\mathbf{i} - 0.8137\mathbf{j} + 0\mathbf{k}.$$

The tensions in the cables are:

$$\mathbf{T}_{BD} = 2\mathbf{u}_{BD} = 0.4529\mathbf{i} - 1.5852\mathbf{j} + 1.1323\mathbf{k} \text{ (kN)},$$

$$\mathbf{T}_{BE} = 2\mathbf{u}_{BE} = 0.8889\mathbf{i} - 1.5556\mathbf{j} - 0.8889\mathbf{k} \text{ (kN)},$$

$$\mathbf{T}_{BC} = 2\mathbf{u}_{BC} = -1.1625\mathbf{i} - 1.6275\mathbf{j} - 0\mathbf{k}.$$

The sum of the moments about A is

$$\sum \mathbf{M}_A = \mathbf{M}^A + \mathbf{r}_{AB} \times \mathbf{T}_{BE}$$

$$+ \mathbf{r}_{AB} \times \mathbf{T}_{BD} + \mathbf{r}_{AB} \times \mathbf{T}_{BC} = 0$$

$$= \mathbf{M}^A + \mathbf{r}_{AB} \times (\mathbf{T}_{BE} + \mathbf{T}_{BC} + \mathbf{T}_{BD})$$

$$\sum \mathbf{M}_A = \mathbf{M}^A + \begin{vmatrix} \mathbf{i} & \mathbf{j} & \mathbf{k} \\ 0 & 70 & 0 \\ 0.1793 & -4.7682 & 0.2434 \end{vmatrix} = 0$$

$$= (M_x^A + 17.038)\mathbf{i} + (M_y^A + 0)\mathbf{j}$$

$$+ (M_z^A - 12.551)\mathbf{k} = 0$$

from which

$$M_x^A = -17.038 \text{ kN}\cdot\text{m},$$

$$M_y^A = 0,$$

$$M_z^A = 12.551 \text{ kN}\cdot\text{m}.$$

The force reactions at A are determined from the sums of forces. (Note that the sums of the cable forces have already been calculated and used above.)

$$\sum \mathbf{F}_X = (A_X + 0.17932)\mathbf{i} = 0,$$

from which $A_X = -0.179 \text{ kN}$,

$$\sum \mathbf{F}_Y = (A_Y - 4.7682)\mathbf{j} = 0,$$

from which $A_Y = 4.768 \text{ kN}$,

$$\sum \mathbf{F}_Z = (A_Z + 0.2434)\mathbf{k} = 0,$$

from which $A_Z = -0.2434 \text{ kN}$

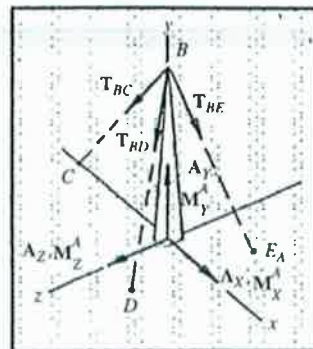
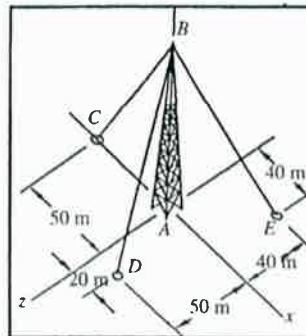

$$0.4529 + 0.8889 - 1.1625 = 0.1793$$

Ex. (2D by Vectors) :

The weight $W_1 = 1000$ lb. Neglect the weight of the bar AB . The cable goes over a pulley at C . Determine the weight W_2 and the reactions at the pin support A .

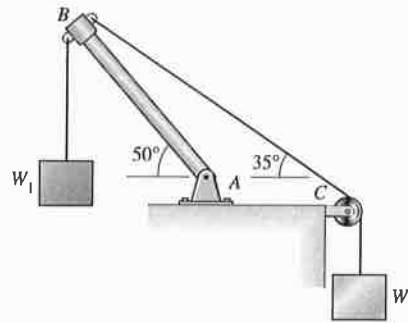

Solution: The strategy is to resolve the tensions at the end of bar AB into x - and y -components, and then set the moment about A to zero. The angle between the cable and the positive x axis is -35° . The tension vector in the cable is

$$\begin{aligned} \mathbf{T}_2 &= W_2(i \cos(-35^\circ) + j \sin(-35^\circ)). \\ &= W_2(0.8192i - 0.5736j)(\text{lb}). \end{aligned}$$

Assume a unit length for the bar. The angle between the bar and the positive x -axis is $180^\circ - 50^\circ = 130^\circ$. The position vector of the tip of the bar relative to A is

$$\mathbf{r}_B = i \cos(130^\circ) + j \sin(130^\circ), = -0.6428i + 0.7660j.$$

The tension exerted by W_1 is $\mathbf{T}_1 = -1000j$. The sum of the moments about A is:

$$\begin{aligned} \sum \mathbf{M}_A &= (\mathbf{r}_B \times \mathbf{T}_1) + (\mathbf{r}_B \times \mathbf{T}_2) = \mathbf{r}_B \times (\mathbf{T}_1 + \mathbf{T}_2) \\ &= L \begin{vmatrix} i & j \\ -0.6428 & 0.7660 \\ 0.8191W_2 & -0.5736W_2 - 1000 \end{vmatrix} \end{aligned}$$

$$\sum \mathbf{M}_A = (-0.2587W_2 + 642.8)\mathbf{k} = 0,$$

from which $W_2 = 2483.5$ lb

The sum of the forces:

$$\sum \mathbf{F}_X = (A_X + W_2(0.8192))i = 0,$$

from which $A_X = -2034.4$ lb

$$\sum \mathbf{F}_Y = (A_Y - W_2(0.5736) - 1000)j = 0,$$

from which $A_Y = 2424.5$ lb

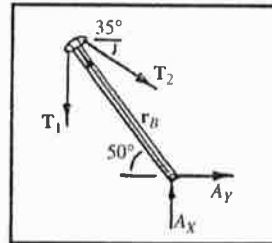
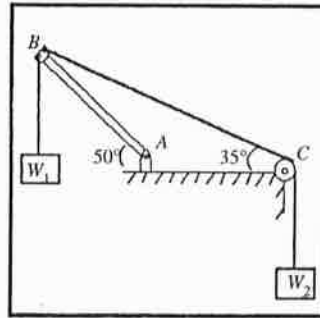

SIMPLE TRUSSES

A truss is a structure composed of slender members joined together at their end points.

The members commonly used consist of wooden struts or metal bars. The joint connections are usually formed by bolting or welding the ends of members to a common plate called a gusset plate, or by passing a large bolt or pin through each of the members.

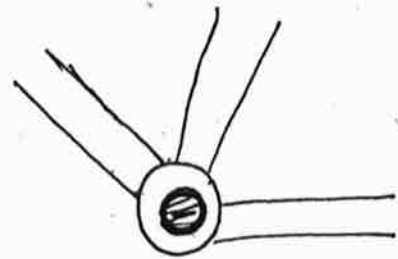
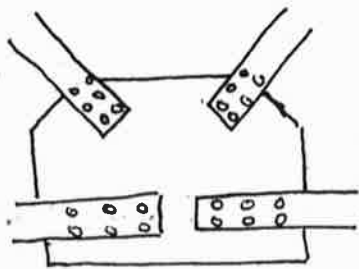

Planar Trusses:

planar trusses lie in a single plane and are used to support roofs and bridges.

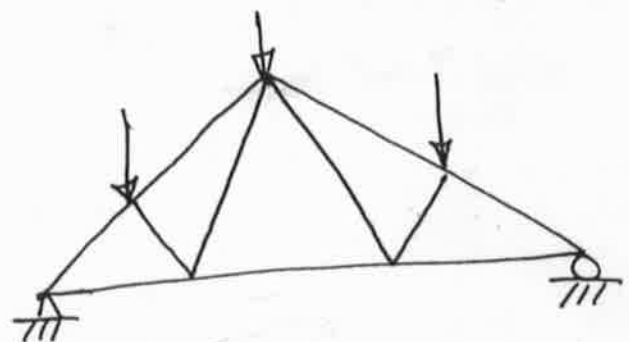
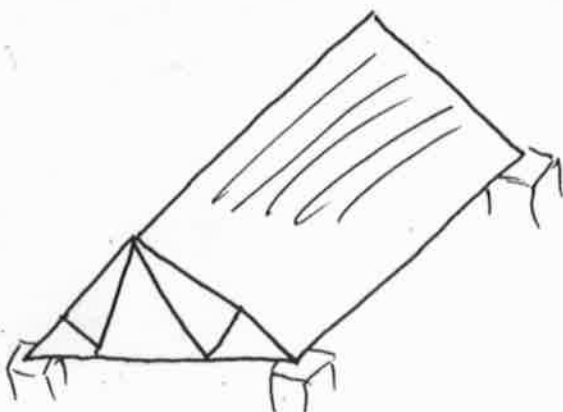

roof truss

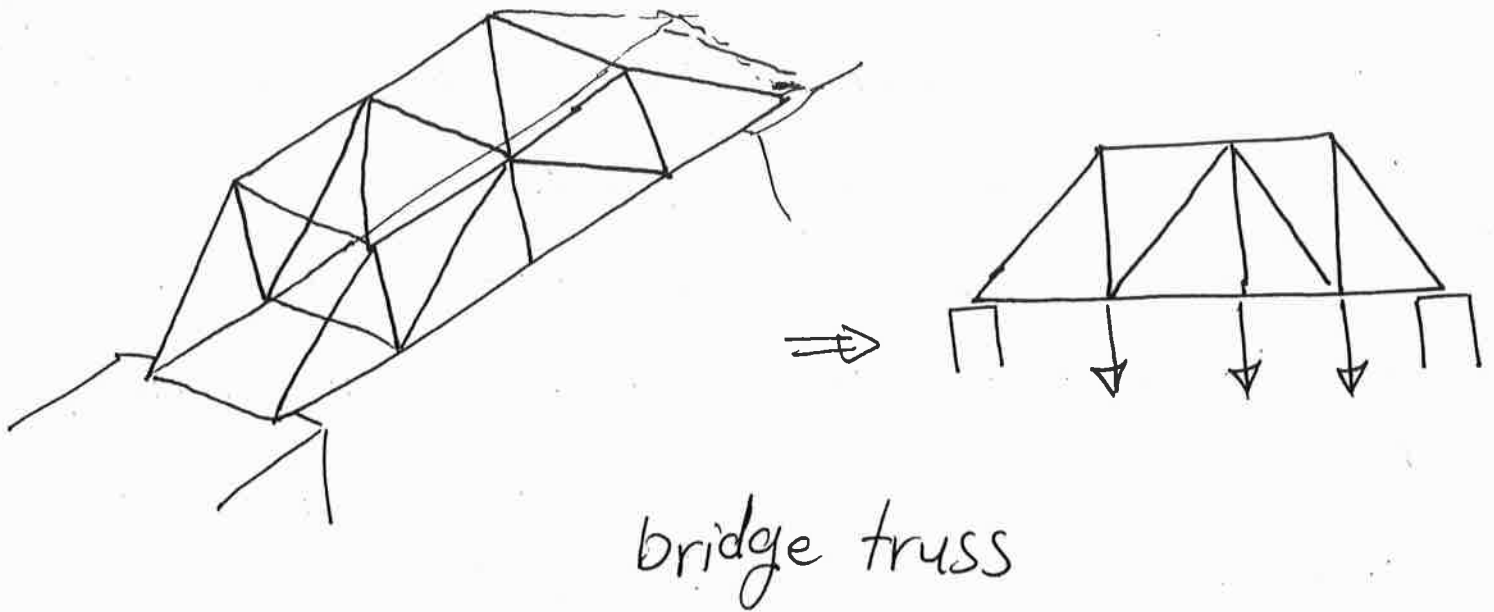

Assumptions for Design

1. All loadings are applied at the joints.
2. The members are joined together by smooth pins.

Because of these two assumptions, the forces at the ends of the member must be directed along the axis of the member. If the force tends to elongate the member, it is a tensile force (T), whereas if it tends to shorten the member, it is a compressive force (C).

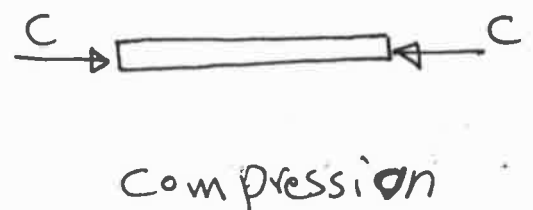
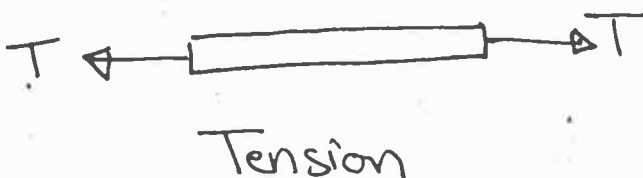

Analysis of a Truss:

The analysis means finding the reactions and the forces in the truss members.

There are two methods to find the forces in the members of the truss:

-1- The joints method.

-2- The sections Method.

① The Method of joints:

In this method, the F.B.D of each joint is drawn.

Then the equilibrium equations $\sum F_x = 0$ and $\sum F_y = 0$ are applied (The equilibrium equation $\sum M = 0$ is satisfied since the forces in each joint are concurrent).

If the sense of direction of force in the member is unknown, assume the force is tension (T).

Notice that the tension forces pulling on the joint while the compression force pushing on the joint.



Procedure for Analysis:

- 1- Draw F.B.D. of a joint have at least one unknown force and at most two unknown member forces.
- 2- If the sense of direction of the force in the member is unknown, assume the force is tension.
- 3- Apply $\sum F_x = 0$ & $\sum F_y = 0$ to find the two unknown member forces.
- 4- Repeat step (1) to (3) for the other joints.

Note: Orient x & y axes such that the forces in F.B.D. can be easily resolved.

Examples (Joint Method):

Ex. 1: Determine the force in each member of the truss.

Sol:

Joint B:

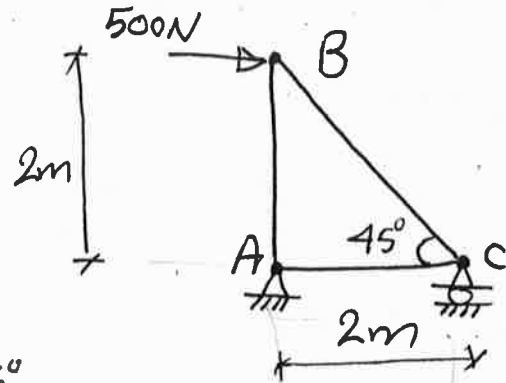
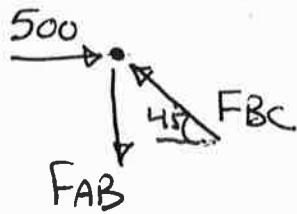

$$\rightarrow \Sigma F_x = 0 \Rightarrow 500 - F_{BC} \cos 45^\circ = 0$$

$$F_{BC} = 707.1 \text{ N (C.)}$$

$$+\uparrow \Sigma F_y = 0 \Rightarrow -F_{AB} + \underbrace{F_{BC} \sin 45^\circ}_{707.1} = 0$$

$$F_{AB} = 500 \text{ N (T.)}$$

Joint C:

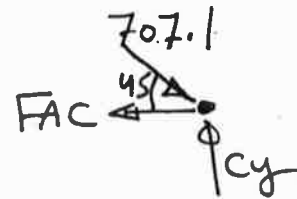

$$\Sigma F_x = 0 \Rightarrow -F_{AC} + 707.1 \cos 45^\circ = 0$$

$$\Rightarrow F_{AC} = 500 \text{ N (T.)}$$

$$\Sigma F_y = 0 \Rightarrow -707.1 \sin 45^\circ + C_y = 0 \Rightarrow C_y = 500 \text{ N } \uparrow$$

Joint A:

$$\Sigma F_x = 0 \Rightarrow A_x = 500 \text{ N } \leftarrow$$

$$\Sigma F_y = 0 \Rightarrow A_y = 500 \text{ N } \downarrow$$

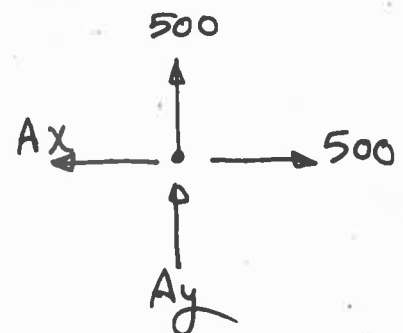

Ex. 2: Determine The force in each member of the truss.

Sol: There are more than two unknowns at each joint.

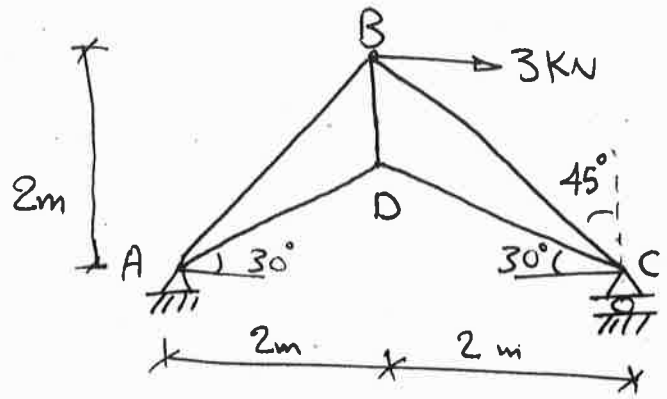

Find the reactions.

$$\sum M_A = 0$$

$$3(2) - C_y(4) = 0 \Rightarrow C_y = 1.5 \text{ kN} \uparrow$$

$$\sum F_y = 0 \Rightarrow A_y = 1.5 \text{ kN} \downarrow$$

$$\sum F_x = 0 \Rightarrow A_x = 3 \text{ kN} \leftarrow$$

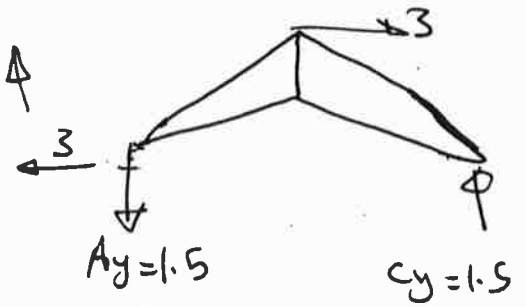

joint C: Use the axes orientation to simplify the solution.

$$\sum F_{\bar{y}} = 0$$

$$1.5 \cos 30^\circ - F_{BC} \sin 15^\circ = 0$$

$$F_{BC} = 5.02 \text{ kN (C)}$$

$$\sum F_{\bar{x}} = 0$$

$$-F_{CD} + 5.02 \cos 15^\circ - 1.5 \sin 30^\circ = 0$$

$$\Rightarrow F_{CD} = 4.1 \text{ kN (T)}$$

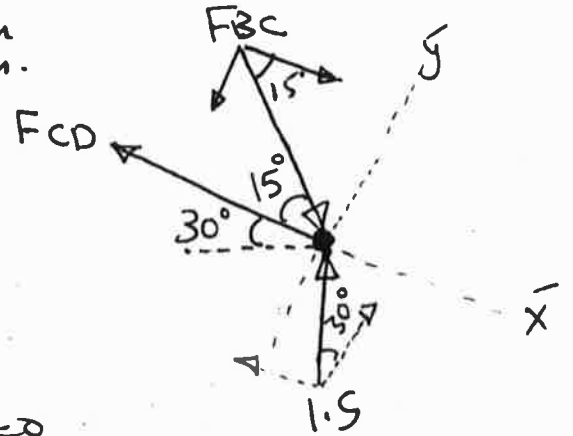

joint D:

$$\sum F_x = 0: 4.1 \cos 30^\circ - F_{AD} \cos 30^\circ = 0$$

$$\Rightarrow F_{AD} = 4.1 \text{ kN (T)}$$

$$\sum F_y = 0: -2(4.1 \sin 30^\circ) + F_{BD} = 0$$

$$\Rightarrow F_{BD} = 4.1 \text{ kN (T)}$$

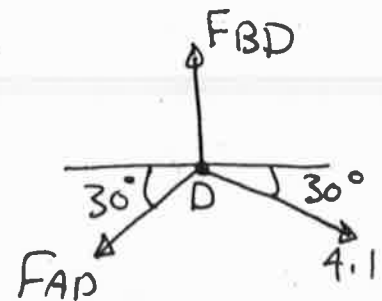

joint (B):

$$\sum F_x = 0: -F_{AB} \sin 45^\circ + 3 - 5.02 \sin 45^\circ = 0$$

$$\Rightarrow F_{AB} = -0.777 \text{ kN} = 0.777 \text{ kN (C)}$$

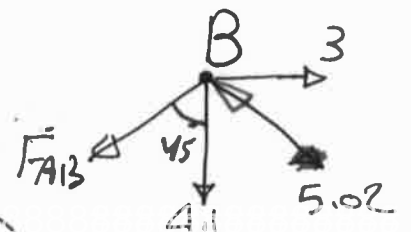

Zero - Force Members:

The Zero - force members are used to increase the stability of the truss during construction and to provide support if the applied loading is changed.

The Zero - force members can be determined by inspection

In general, there are two cases:

1 - If only two members form a truss joint and no external load or support reaction is applied to the joint these two members are Zero - force members.

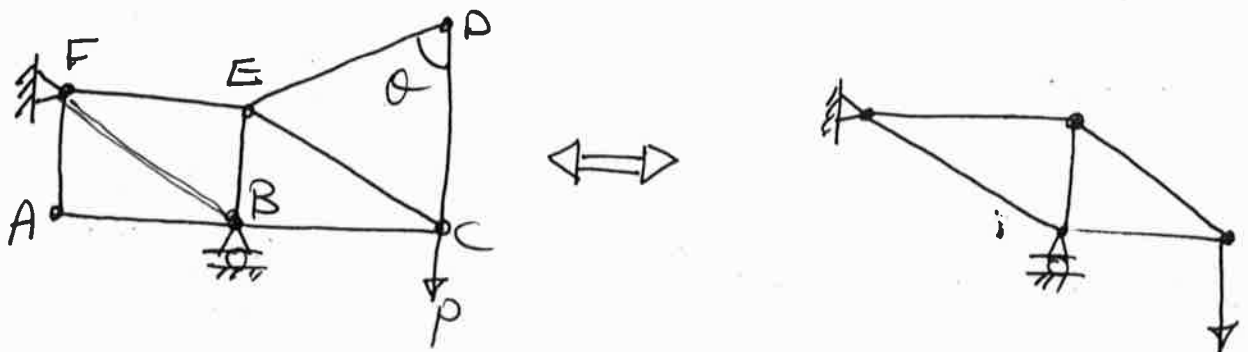

joint (A)

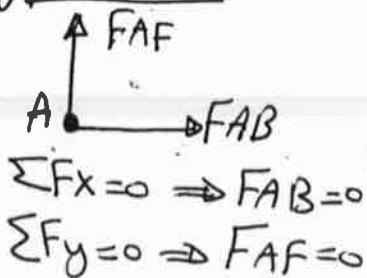

joint (D)

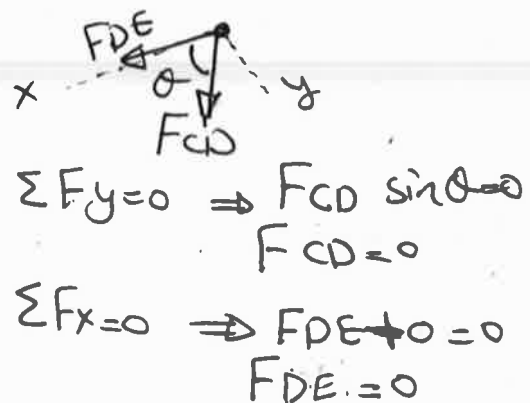

2- If three members form a truss joint for which two of the members are collinear and no external load or support reaction is applied to the joint, the third member is zero-force members.

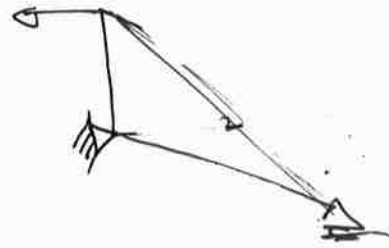
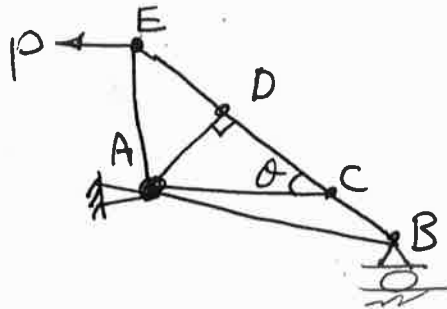

Joint D

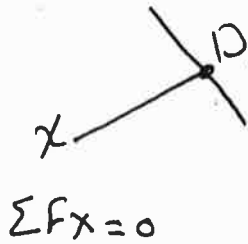

$$\sum F_x = 0$$

Joint C

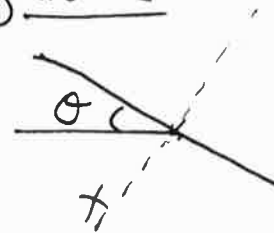

$$\sum F_x = 0$$

Ex 3: Determine the Zero force members.

Sol:

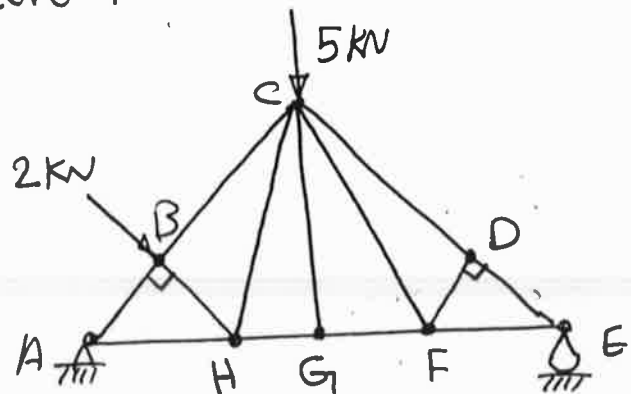

From joint G: $F_{GC} = 0$

From joint D: $F_{DF} = 0$

From joint F: $F_{CF} = 0$

Notice that From joint (B): $F_{BH} = 2kN (C)$

Ex: 4: Determine the forces in each member:

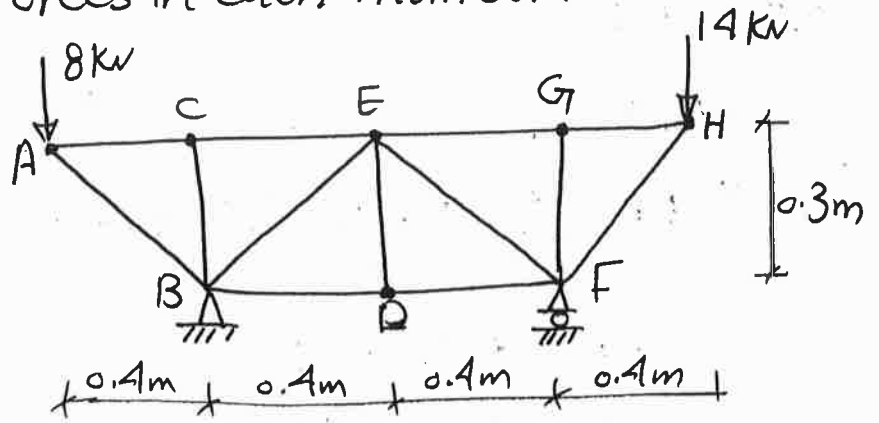

Sol:

$$F_{BC} = 0$$

$$F_{DE} = 0$$

$$F_{GF} = 0$$

joint A:

$$\sum F_y = 0 \Rightarrow F_{AB} \left(\frac{3}{5}\right) = 8 \quad \boxed{F_{AB} = 13.33 \text{ kN (C.)}}$$

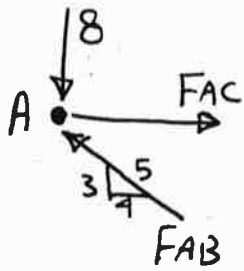

$$\sum F_x = 0 \Rightarrow F_{AC} = 13.33 \times \frac{4}{5} = \boxed{10.67 \text{ kN (T.)}}$$

joint C:

$$F_{CE} = F_{AC} = 10.67 \text{ (T.)}$$

joint H:

$$\sum F_y = 0 \Rightarrow F_{FH} \left(\frac{3}{5}\right) = 14 \Rightarrow \boxed{F_{FH} = 23.33 \text{ (C.)}}$$

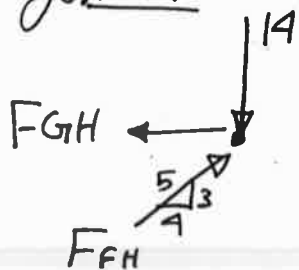

$$\sum F_x = 0 \Rightarrow F_{GH} = 23.33 \left(\frac{4}{5}\right) = \boxed{18.67 \text{ (T.)}}$$

joint G:

$$F_{EG} = F_{HG} = 18.67 \text{ (T.)}$$

Entire Truss: $\sum M_B = 0$

$$-8(0.4) - F_y(0.8) + 14(1.2) = 0$$

$$\Rightarrow \boxed{F_y = 17 \text{ kN } \uparrow}$$

joint F:

$$\sum F_y = 0$$

$$\Rightarrow F_{FE} \left(\frac{3}{5} \right) - 23.33 \left(\frac{3}{5} \right) + 17 = 0$$

$$F_{FE} = -5 \text{ kN}$$

$$F_{FE} = 5 \text{ kN (C.)}$$

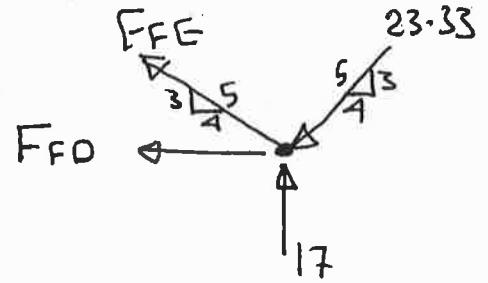

$$\sum F_x = 0$$

$$\Rightarrow -F_{FD} + 5 \left(\frac{4}{5} \right) - 23.33 \left(\frac{4}{5} \right) = 0$$

$$\Rightarrow F_{FD} = -14.67 = 14.67 \text{ kN (C.)}$$

joint D:

$$F_{BD} = F_{FD} = 14.67 \text{ (C.)}$$

joint E:

$$\sum F_y = 0$$

$$\Rightarrow 5 \left(\frac{3}{5} \right) - F_{BE} \left(\frac{3}{5} \right) = 0$$

$$\Rightarrow F_{BE} = 5 \text{ kN (T.)}$$

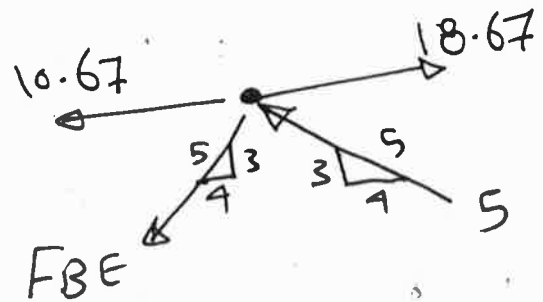

② The Method of sections:

This method is based on the principle that if a body is in equilibrium, ~~or~~ then any part of the body is also in equilibrium.

The method of sections involves cutting the truss into two parts by passing an imaginary section through the members whose forces are desired.

Then, the equilibrium eqs. ($\sum F_x = 0$, $\sum F_y = 0$ and $\sum M_o = 0$) are applied to the isolated part of the truss.

Procedure For Analysis:-

- 1- Select a section that passes through members whose forces are desired, but generally not more than three members with unknown forces.
- 2- Draw F.B.D. of the part of truss which has the least number of forces acting on it.
- 3- Apply the equilibrium eqs. to find the unknowns.

Ex: 1: Determine the forces in members CD, DG, and GH of the truss.

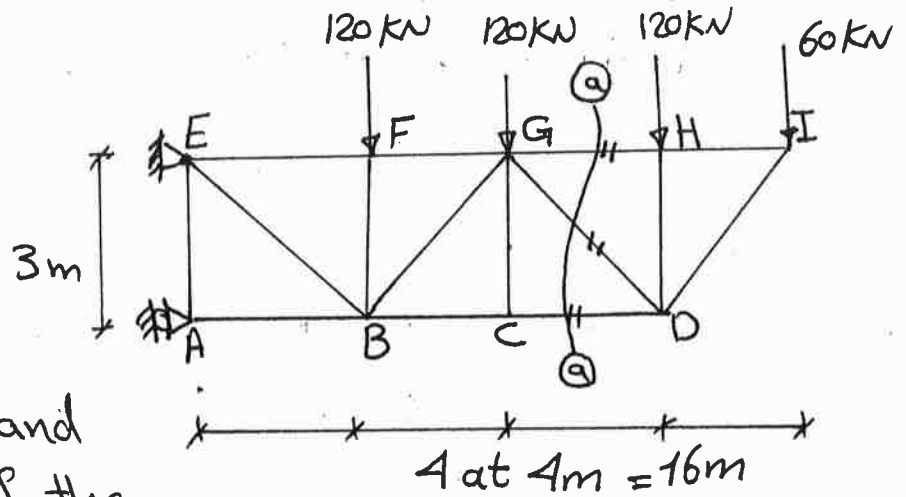

Sol:

Select section (a-a) and take the right part of the truss.

$$\sum M_D = 0$$

$$-F_{GH}(3) + 60(4) = 0$$

$$\Rightarrow F_{GH} = 80 \text{ kN (T.)}$$

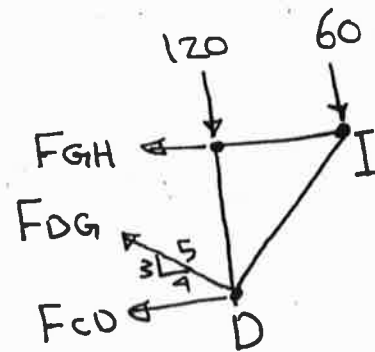

$$\sum F_y = 0$$

$$-120 - 60 + F_{DG} \left(\frac{3}{5} \right) = 0$$

$$\Rightarrow F_{DG} = 300 \text{ kN (T.)}$$

$$\sum F_x = 0$$

$$-80 - 300 \left(\frac{4}{5} \right) - F_{CD} = 0$$

$$\Rightarrow F_{CD} = -320 = 320 \text{ kN (C.)}$$

For checking:

$$\sum M_I = 0: \quad -320(3) + 300 \left(\frac{4}{5} \right) (3) + 300 \left(\frac{3}{5} \right) (4) - 120(4) = \text{Zero} \quad \underline{\underline{\text{o.k.}}}$$

Ex: 2: Determine the force in members GF, CF, and CD.

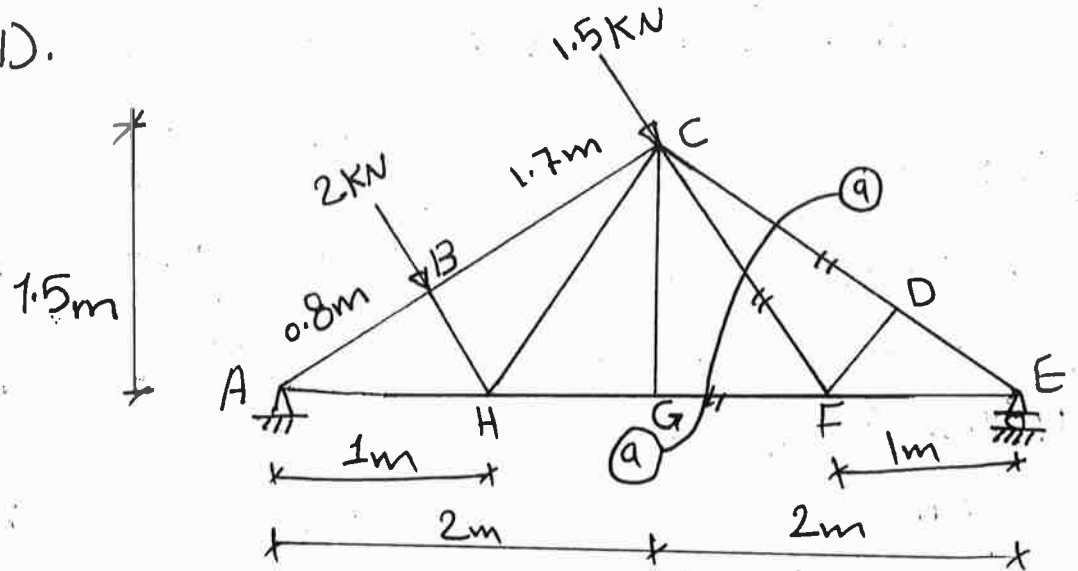

Sol:

First find E_y :

$$\sum M_A = 0$$

$$2(0.8) + 1.5(2.5) - E_y(4) = 0 \Rightarrow E_y = 1.3375 \text{ kN} \uparrow$$

Section a-a

$$\sum M_C = 0$$

$$F_{GF}(1.5) - 1.3375(2) = 0$$

$$\sum M_F = 0 \Rightarrow F_{GF} = 1.783 \text{ kN (T)}$$

$$-F_{CD} \left(\frac{3}{5}\right)(1) - 1.3375(1) = 0$$

$$\Rightarrow F_{CD} = -2.23 = 2.23 \text{ kN (C)}$$

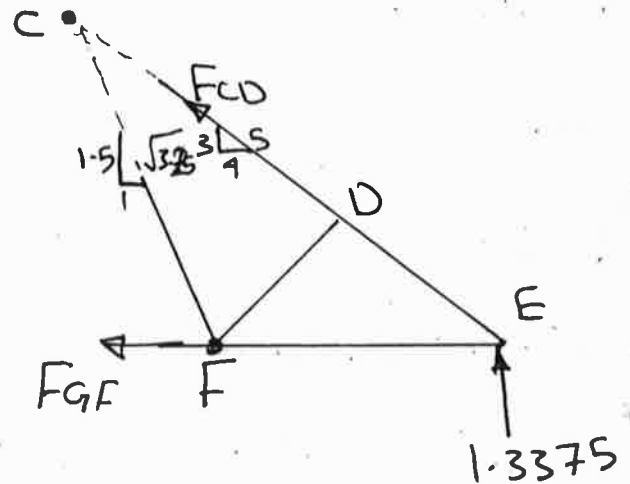

$$\sum M_E = 0$$

$$F_{CF} \left(\frac{1.5}{\sqrt{3.25}}\right)(1) = 0 \Rightarrow F_{CF} = 0$$

or directly = 0

Ex: 3: Determine the force in members F_{JH} , F_{JK} , and F_{FJ} of the K truss shown in the Fig.

Sol:

We cannot solve this problem by sec. (b)-(b) 4 unknowns with 3 eqs.

but sec. (a)-(a) can be selected since three member pass through one joint.

Take upper part:

$$\sum M_I = 0$$

$$25(8) + F_{HK}(12) = 0$$

$$F_{HK} = -16.67 = 16.67 \text{ kN (C.)}$$

Select sec. (b)-(b):

$$\sum M_F = 0$$

$$25(16) + 50(8) - 16.67(12) + F_{HJ} \left(\frac{4}{5}\right)(6) + F_{HJ} \left(\frac{3}{5}\right)(8) = 0$$

$$\Rightarrow F_{HJ} = -62.5 = 62.5 \text{ kN (C.)}$$

$$\sum F_x = 0 \Rightarrow -F_{FJ} \left(\frac{3}{5}\right) - 62.5 \left(\frac{3}{5}\right) + 50 + 25 = 0$$

$$F_{FJ} = 62.5 \text{ kN (T.)}$$

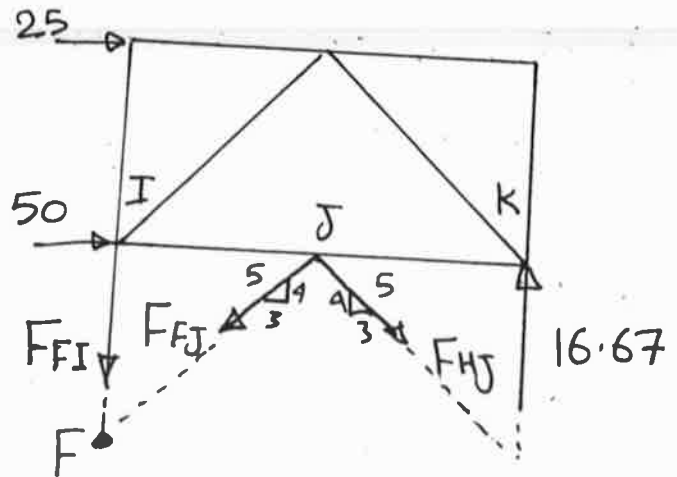
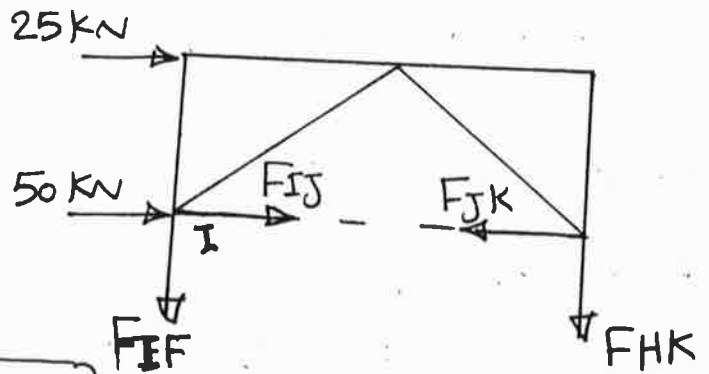
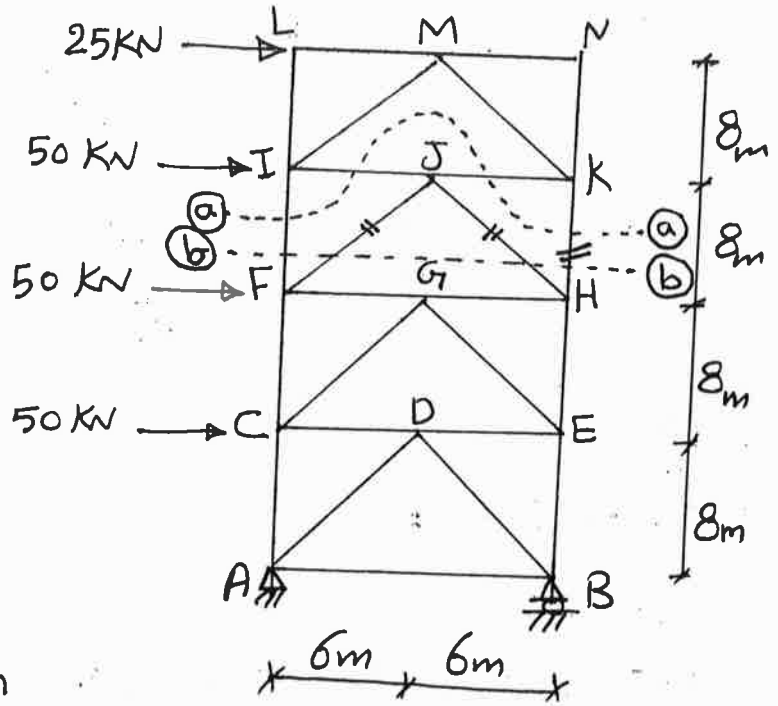

Ex: 4: Determine the force in member EB.

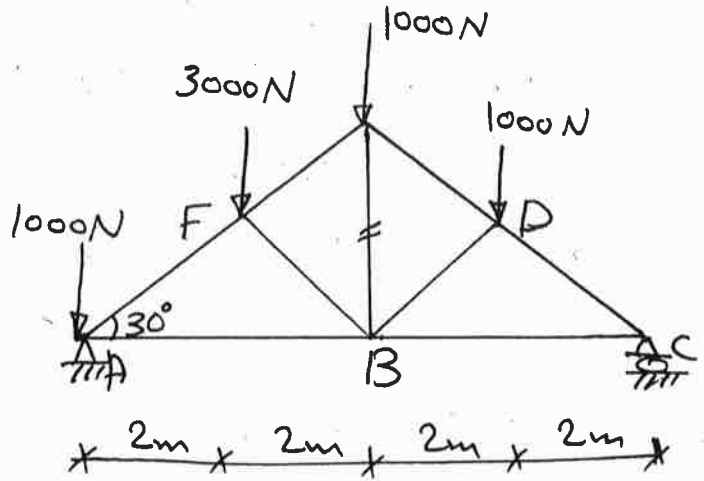

SOL:

First find reaction at C:

$$\sum M_A = 0 \Rightarrow 3000(2) + 1000(4) + 1000(6) - C_y(8) = 0$$

$$\Rightarrow C_y = 2000 \text{ N } \uparrow$$

select sec. (a) - (a)

Take right part:

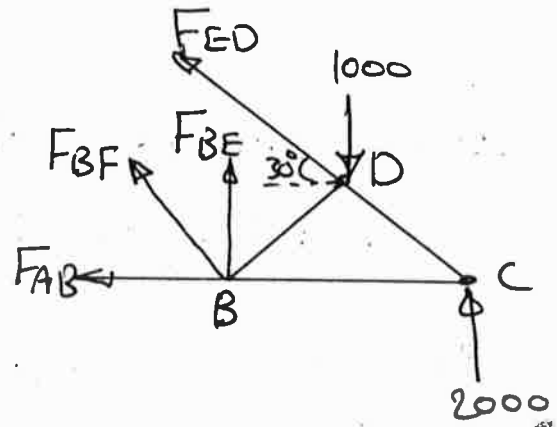

$$\sum M_B = 0$$

$$-F_{ED} \sin 30^\circ(4) - 2000(4) + 1000(2) = 0$$

$$F_{ED} = -3000 = 3000 \text{ N (C.)}$$

select sec. (b) - (b)

$$\sum F_x = 0$$

$$-F_{EF} \cos 30 - 3000 \cos 30 = 0$$

$$F_{EF} = -3000 = 3000 \text{ N (C.)}$$

$$\sum F_y = 0$$

$$2(3000 \sin 30) - 1000 = F_{EB}$$

$$\Rightarrow F_{EB} = 2000 \text{ N (T.)}$$

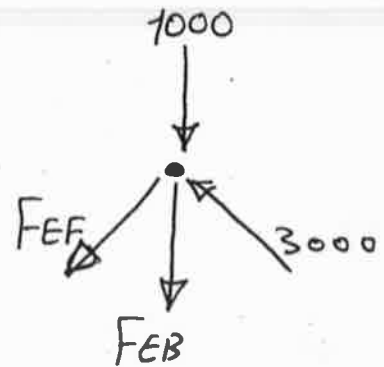

Ex. 5: | If the maximum force that any member can support is 8 kN in tension and 6 kN in compression, determine the maximum force (P) in kN that can be supported at D.

Sol: Method of joints:

joint(D): $F_{DC} = 1.1547P(T)$
 $F_{DE} = 0.57735P(C.)$

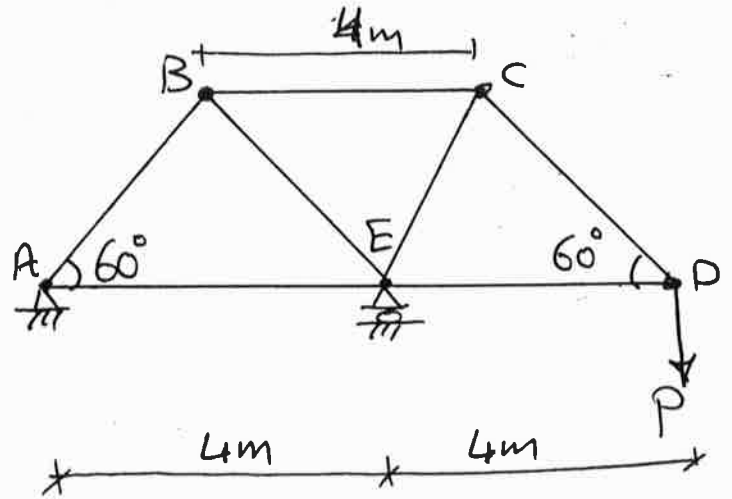

joint(C): $F_{CE} = 1.1547P(C.)$
 $F_{CB} = 1.1547P(T.)$

joint(B): $F_{BE} = 1.1547P(C.)$
 $F_{BA} = 1.1547P(T.)$

joint(E): $F_{EA} = 0.57735P(C.)$

From the resultants:

Max. compression force = $1.1547P$

Max. tension = $1.1547P$

For compression: $1.1547P = 6 \Rightarrow P = 5.20 \text{ kN}$

For tension: $1.1547P = 8 \Rightarrow P = 6.92 \text{ kN}$

$\Rightarrow P = 5.20 \text{ kN}$

Ex.

16: Determine the force in member CF of the bridge truss shown in the Fig.

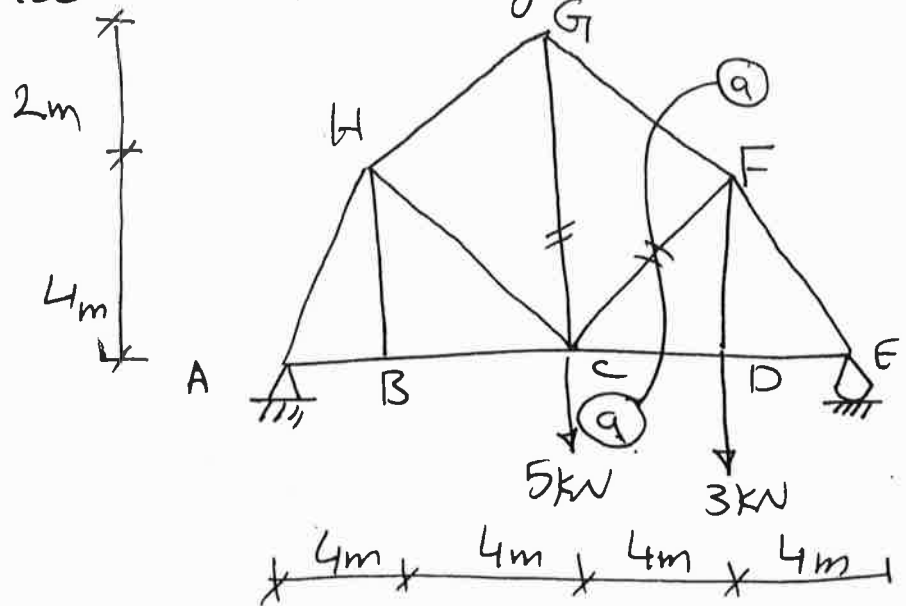

Sol:

Select section a-a and take the right part
 First find the reaction at E:

$$+\circlearrowleft \sum M_A = 0 \Rightarrow 5(8) + 3(12) - E_y(16) = 0$$

$$\Rightarrow E_y = 4.75 \text{ kN} \uparrow$$

Section a-a:

$$\frac{1}{2} = \frac{4}{d} \Rightarrow d = 8$$

$$\therefore x = 8 - 4 = 4 \text{ m}$$

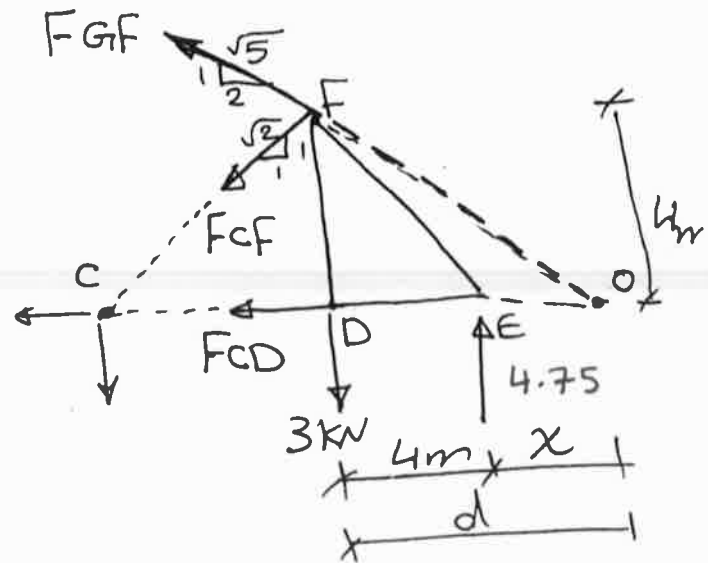

$$\sum M_O = 0$$

$$-F_{CF} \left(\frac{1}{\sqrt{2}} \right) (12) - 3(8) + 4.75(4) = 0$$

$$\Rightarrow F_{CF} = -0.589 = 0.589 \text{ kN (C.)}$$

Frames and Machines :

Frames and machines are two common types of structure which are often composed of pin connected parts.

Frames are used to support loads whereas machines, which contain moving parts, are used to transmit and alter the forces.

In the analysis of frames and machines, the FBD for the parts are drawn, and the three equations of equilibrium can be applied for the parts (and/or) for the entire structure.

When FBD is drawn for the pin connected parts, the internal reactions at the connection pin must be equal and opposite for each part.

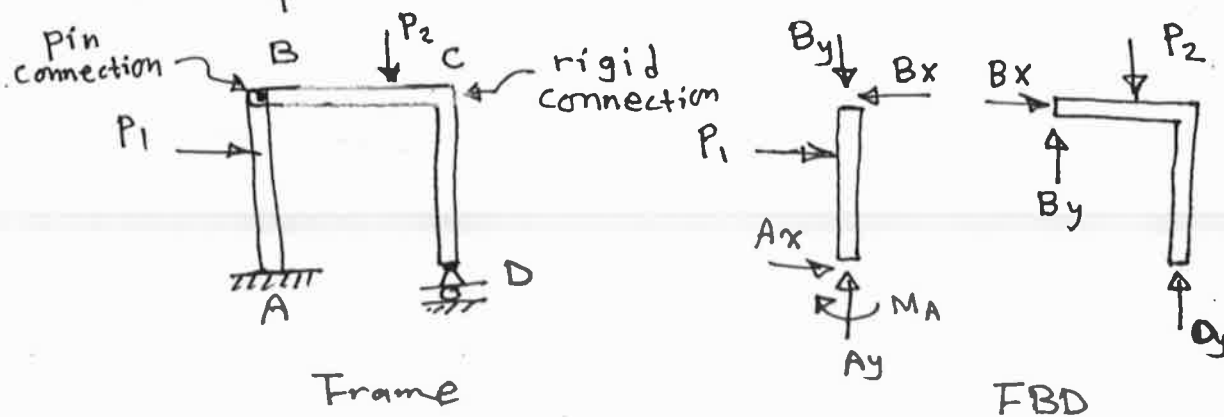

Two-Force Member: The two-force member is a member with two equal and opposite forces at its ends. The member with pins (or hinges) at its ends with no loads or supports between ends is a two-force member.

Examples for the two-force member :

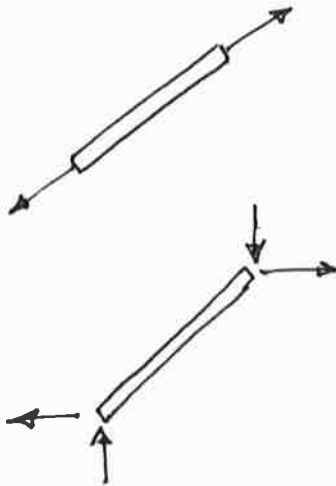
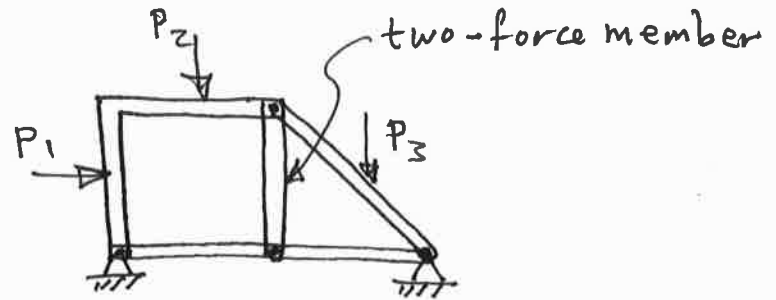
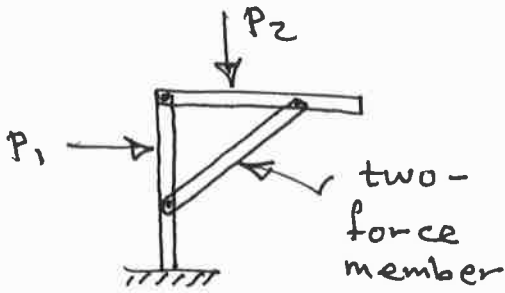

FBD if the two-force member recognized



FBD if the two-force member does not recognized

If the two-force member is recognized before analysis, then the number of internal reactions (unknowns) at the two ends will be reduced from two reactions to only one reaction at each end, which simplify the calculations.

It is important to identify the two-force member before analysis to make the analysis more simpler.

Note that the two-force member works like the truss member or the link support.

Examples :

Ex.1 : Draw the FBD for the frame shown in the figure for (a) Each member (b) Members ABC & BD together.

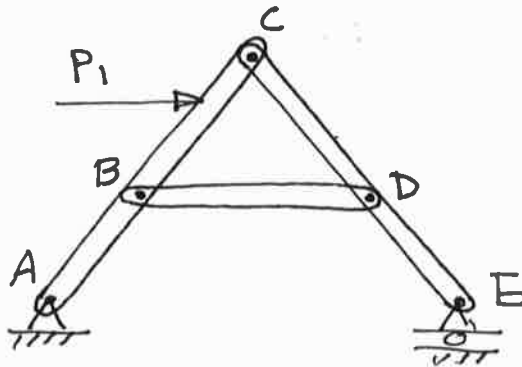

Sol. The member BD is two-force member.

(a) For each member:

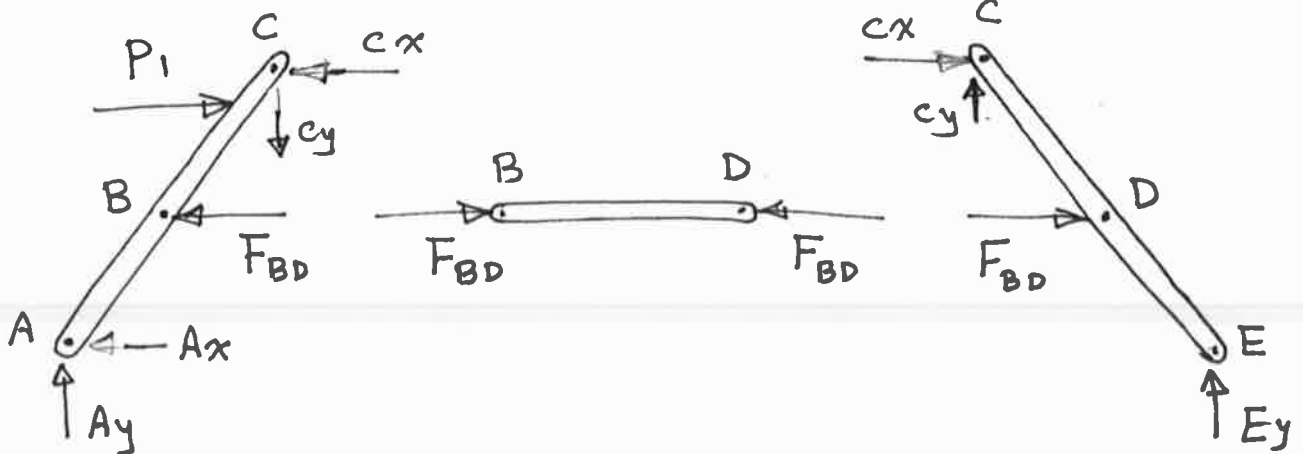

(b) For members ABC & BD together:

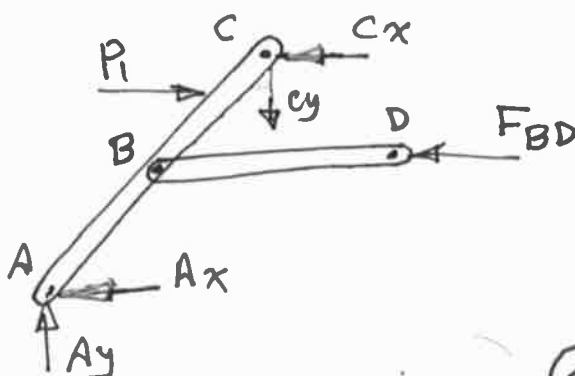

Ex.2 : Draw FBD for each member .

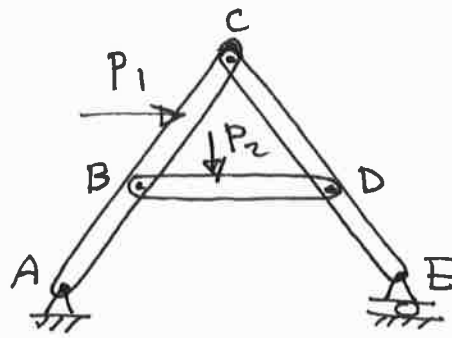

Similar to the frame in Ex.1, but the force P_2 is added over the member BD .

Sol. There is no two-force member.

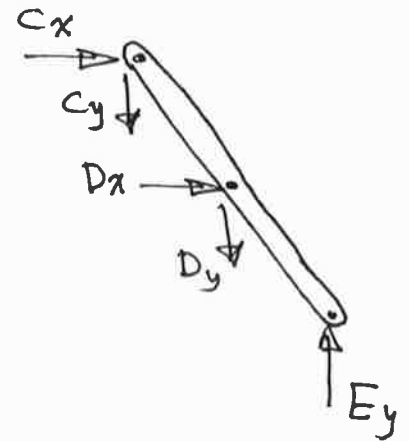
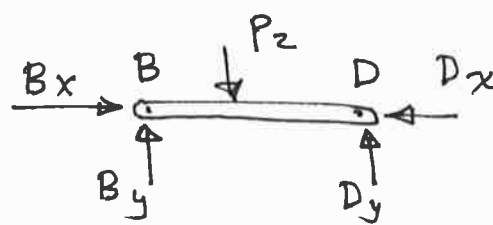
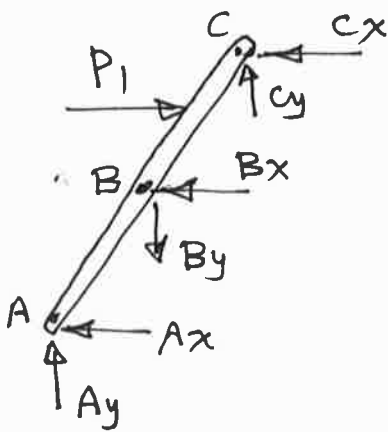

Ex.3 : Draw FBD for each member :

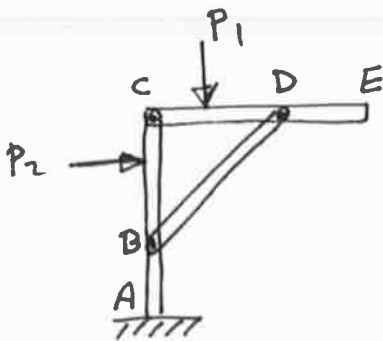

FBD →

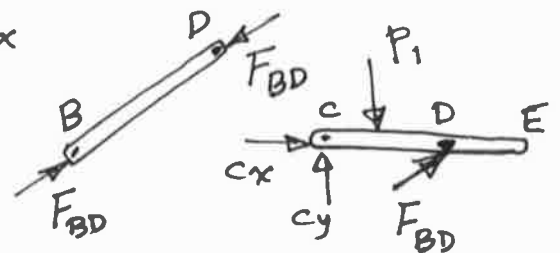
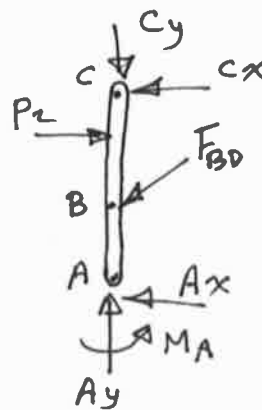

Note that BD is two-force member

Ex.4 : Determine the reactions at C .

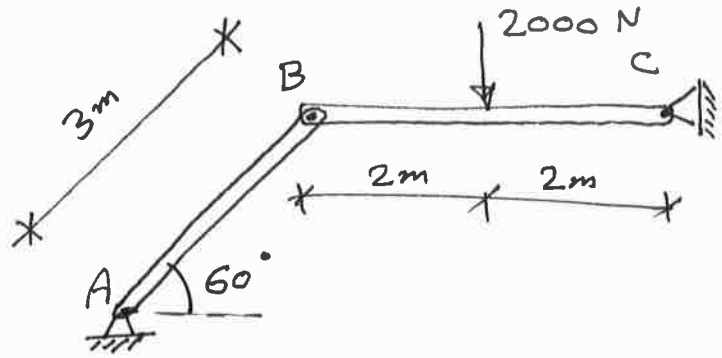

Sol. AB is two-force member.

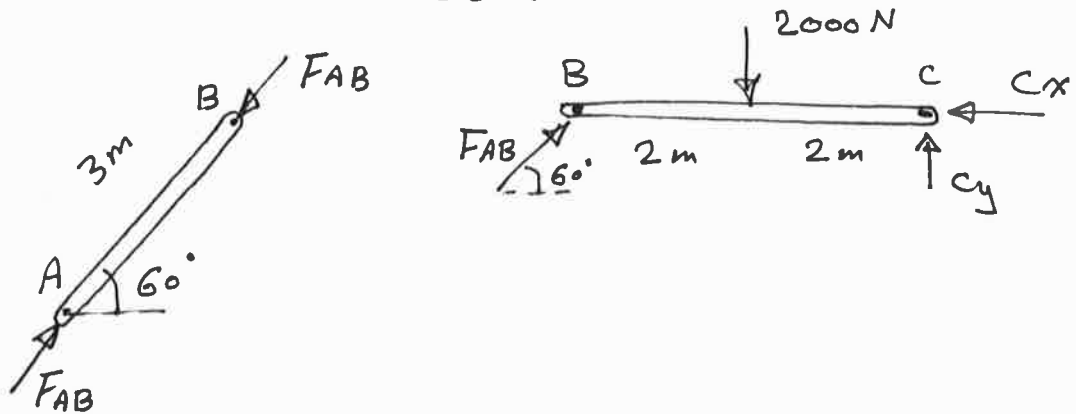

(FBD)_{BC} : $\sum M_C = 0$: $-2000(2) + F_{AB} \sin 60(4) = 0$
 $\Rightarrow F_{AB} = 1154.7 \text{ N}$

$\uparrow \sum F_y = 0$: $1154.7 \sin 60 - 2000 + C_y = 0 \Rightarrow C_y = 1000 \text{ N} \uparrow$

$\rightarrow \sum F_x = 0$: $1154.7 \cos 60 - C_x = 0 \Rightarrow C_x = 577.35 \text{ N} \leftarrow$

Notice : If one does not recognize that AB is two-force member, then more work is needed to solve the problem, as shown below:

(FBD)_{BC} : $\sum M_B = 0 \Rightarrow C_y = 1000 \text{ N} \uparrow$
 $\sum F_y = 0 \Rightarrow B_y = 1000 \text{ N} \uparrow$
 $\sum F_x = 0 \Rightarrow B_x - C_x = 0 \text{ --- ①}$

(FBD)_{AB} : $\sum M_A = 0 \Rightarrow B_y(3 \cos 60) - B_x(3 \sin 60) = 0 \Rightarrow B_x = 577.35 \text{ N} \leftarrow$
 substitute into eq. ① $\Rightarrow C_x = 577.35 \text{ N} \leftarrow$

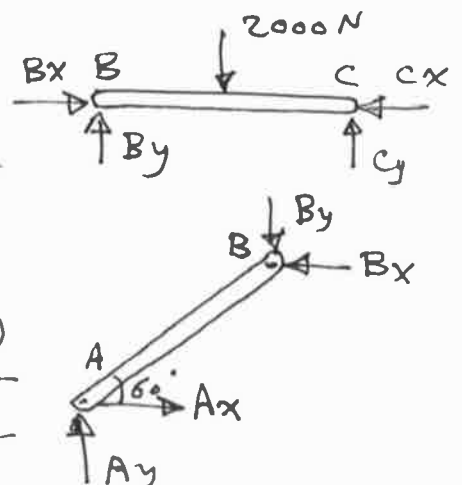

Ex.5 : Determine the reactions at pin C .

Sol.

$$W = 100 \times 9.81 = 981 \text{ N}$$

The member BE is two-force member.

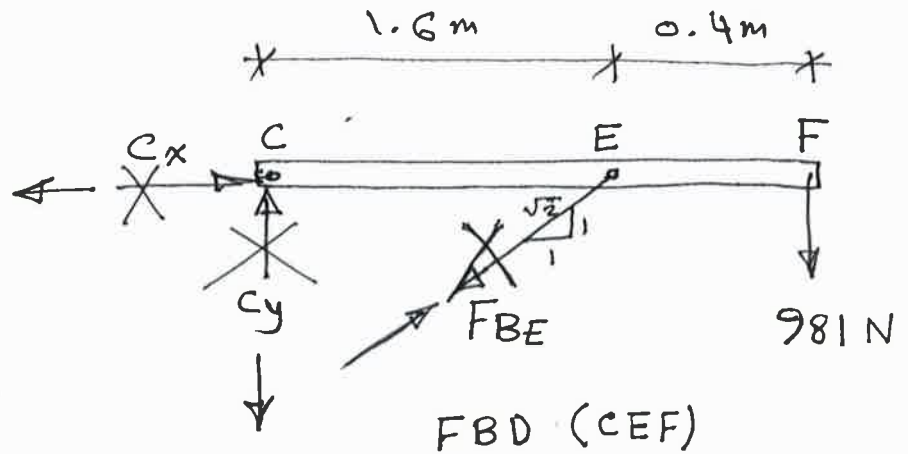
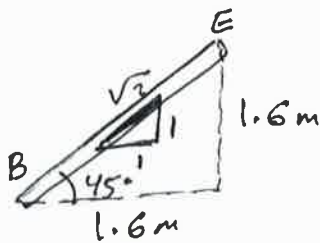
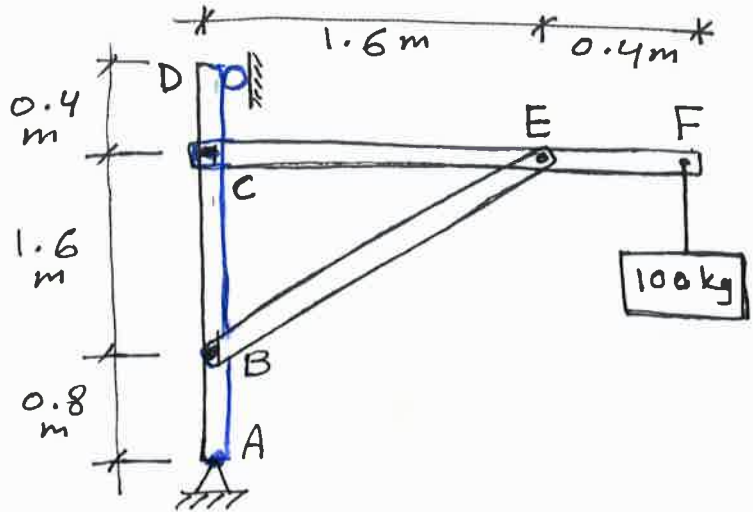

FBD (CEF):

$$\curvearrow + \sum M_C = 0$$

$$F_{BE} \left(\frac{1}{\sqrt{2}} \right) (1.6) + 981 (2) = 0 \Rightarrow F_{BE} = -1734.17$$

$$\Rightarrow F_{BE} = 1734.17 \text{ N} \nearrow$$

$$\uparrow + \sum F_y = 0 : C_y + 1734.17 \left(\frac{1}{\sqrt{2}} \right) - 981 = 0 \Rightarrow C_y = -245.25$$

$$\Rightarrow C_y = 245.25 \text{ N} \downarrow$$

$$\rightarrow + \sum F_x = 0 : C_x + 1734.17 \left(\frac{1}{\sqrt{2}} \right) = 0 \Rightarrow C_x = -1226.24$$

$$\Rightarrow C_x = 1226.24 \text{ N} \leftarrow$$

Ex. 6 :

Determine the horizontal and vertical components of forces at pins A, B, and C.

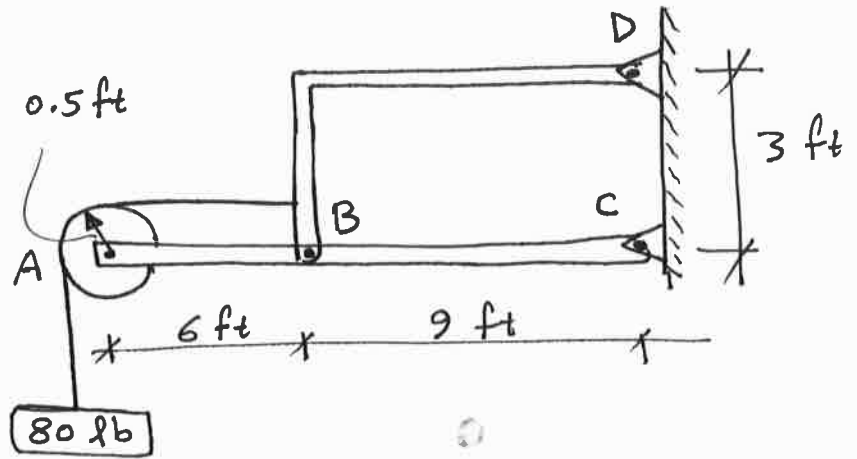

Sol.

FBD (Pulley A) :

$$\rightarrow \Sigma F_x = 0 \Rightarrow \boxed{A_x = 80 \text{ lb} \leftarrow}$$

$$\uparrow \Sigma F_y = 0 \Rightarrow \boxed{A_y = 80 \text{ lb} \uparrow}$$

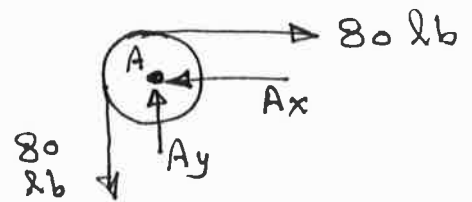

FBD (ABC) :

$$\curvearrow \Sigma M_c = 0$$

$$-80(15) + B_y(9) = 0 \Rightarrow \boxed{B_y = 133.33 \text{ lb} \uparrow}$$

$$\uparrow \Sigma F_y = 0$$

$$-80 + 133.33 + C_y = 0 \Rightarrow C_y = -53.33 \Rightarrow \boxed{C_y = 53.33 \text{ lb} \downarrow}$$

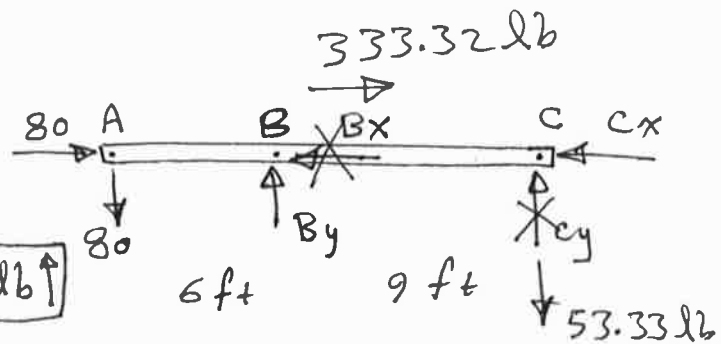

FBD (BD) :

$$\curvearrow \Sigma M_D = 0$$

$$80(2.5) - B_x(3)$$

$$-133.33(9) = 0$$

$$\Rightarrow B_x = -333.32 = \boxed{333.32 \text{ lb} \leftarrow}$$

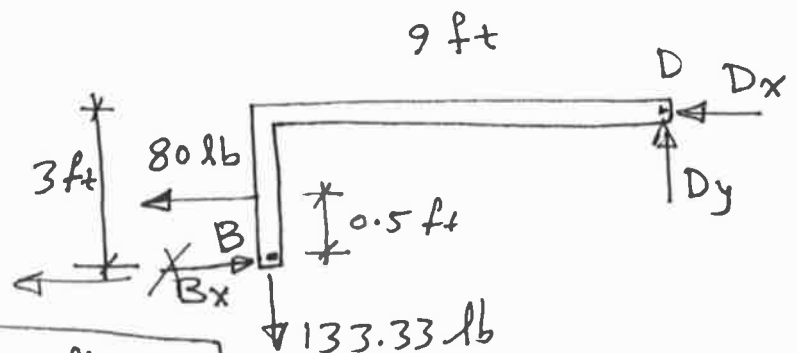

FBD (ABC) : $\rightarrow \Sigma F_x = 0 : 80 + 333.32 - C_x = 0 \Rightarrow \boxed{C_x = 413.32 \text{ lb} \leftarrow}$

Ex.7 :

Determine the force P needed to support the 200 kg mass. Also what are the reactions at hooks A, B, and C ?

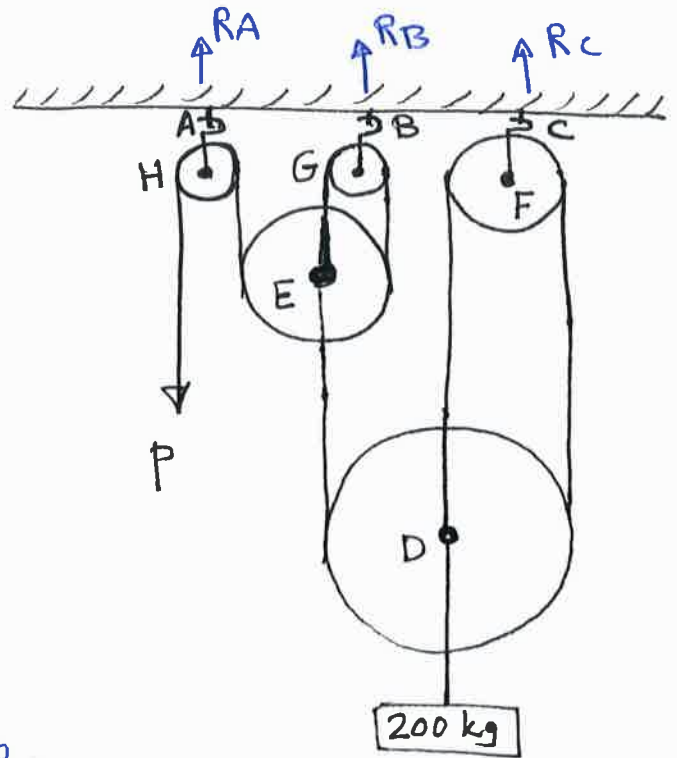

Sol. $W = 200 \times 9.81$
 $= 1962 \text{ N}$

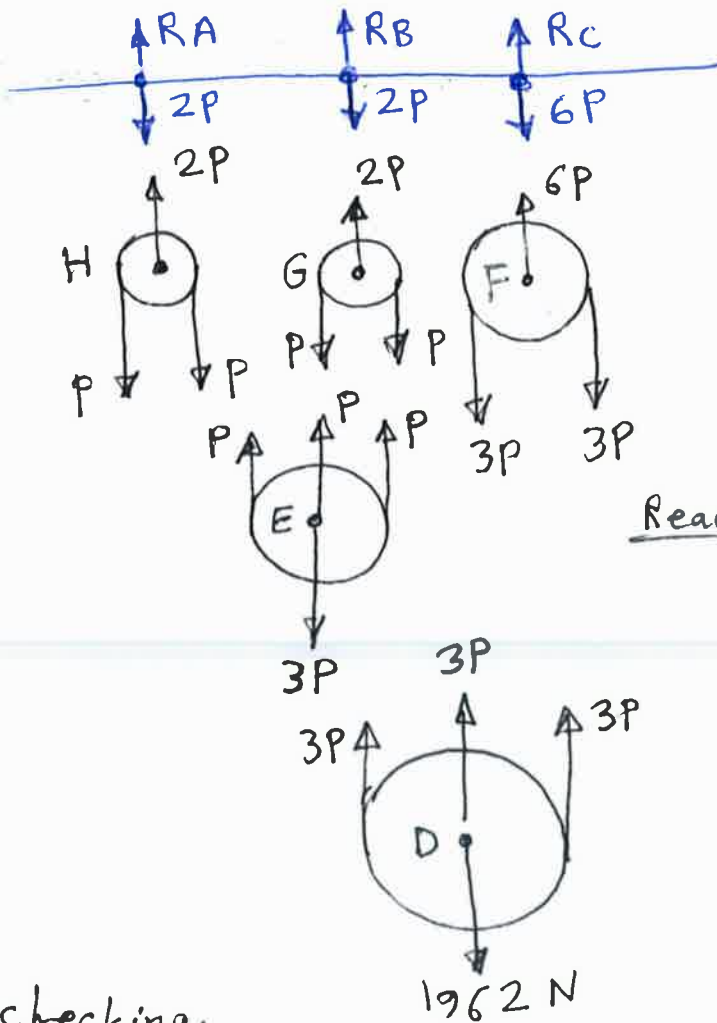

FBD (D) :

$$9P = 1962$$

$$\Rightarrow P = 218 \text{ N}$$

Reactions: $R_A = 2P = 436 \text{ N} \uparrow$

$R_B = 2P = 436 \text{ N} \uparrow$

$R_C = 6P = 1308 \text{ N} \uparrow$

For checking:

Entire system: $\uparrow \Sigma F_y = 0 ; R_A + R_B + R_C - P - 1962 = 0$
 $436 + 436 + 1308 - 218 - 1962 = 0$

Ex. 8 :

Determine the forces at pins B and C on member ABC.

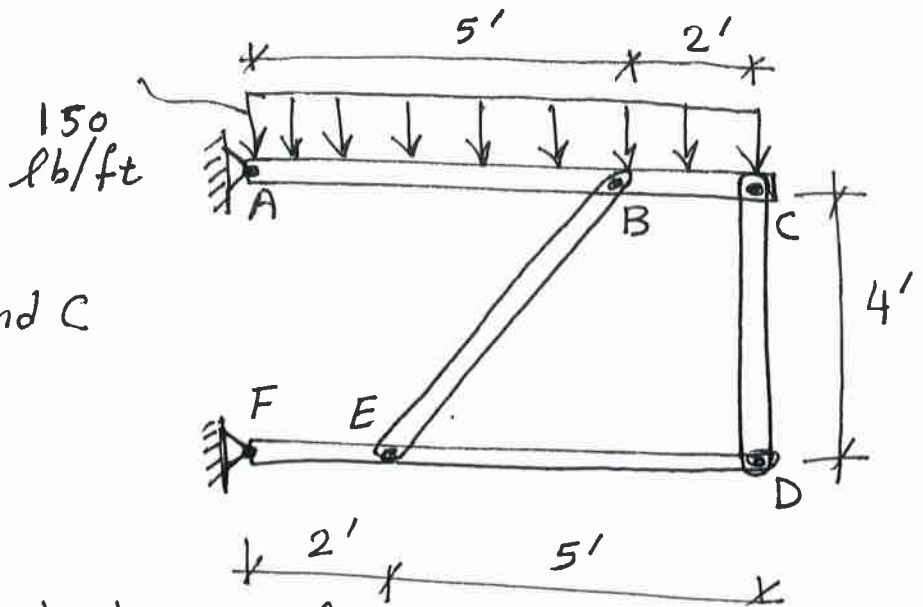

Sol.: EB and CD are both two-force members.

FBD (ABC):

$$\sum M_A = 0$$

$$1050(3.5) - F_{BE} \left(\frac{4}{5}\right)(5) - F_{CD}(7) = 0$$

$$\Rightarrow F_{CD} = 525 - \frac{4}{7} F_{BE} \quad \text{--- ①}$$

$$150 \times 7 = 1050 \text{ lb}$$

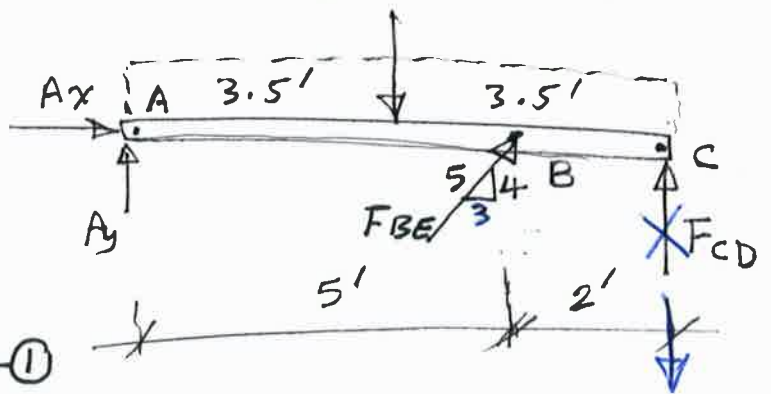

FBD (DEF):

$$\sum M_F = 0$$

$$F_{BE} \left(\frac{4}{5}\right)(2) + F_{CD}(7) = 0 \quad \text{--- ②}$$

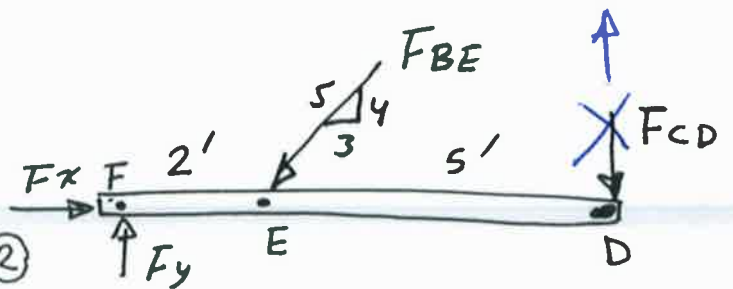

Substitute eq. ① into eq. ②:

$$\Rightarrow F_{BE} \left(\frac{8}{5}\right) + 7 \left(525 - \frac{4}{7} F_{BE}\right) = 0$$

$$\Rightarrow F_{BE} = 1531.25 \text{ lb } \swarrow$$

$$\Rightarrow F_{CD} = -350 = 350 \text{ lb } \uparrow$$

Ex.9 : Determine the reactions at A and B .

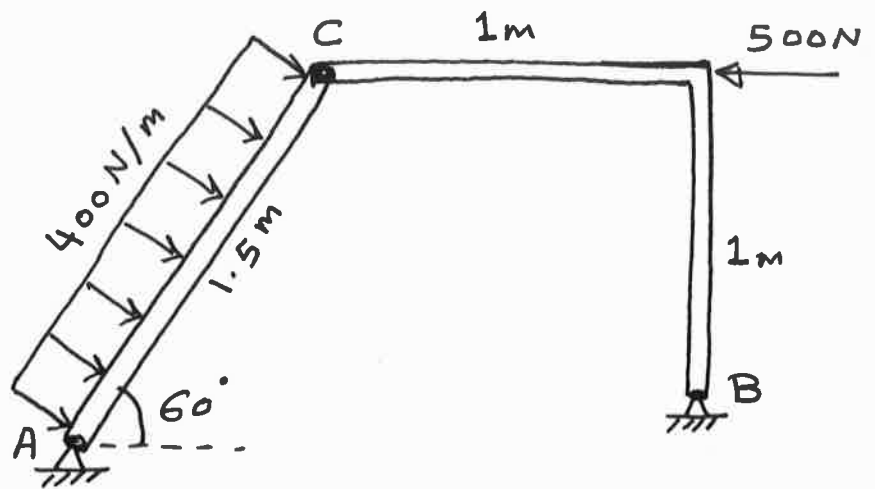

Sol.

FBD (AC) :

$$\sum M_A = 0$$

$$- C_x (1.5 \sin 60) - C_y (1.5 \cos 60) + 600 (0.75) = 0 \quad \text{--- ①}$$

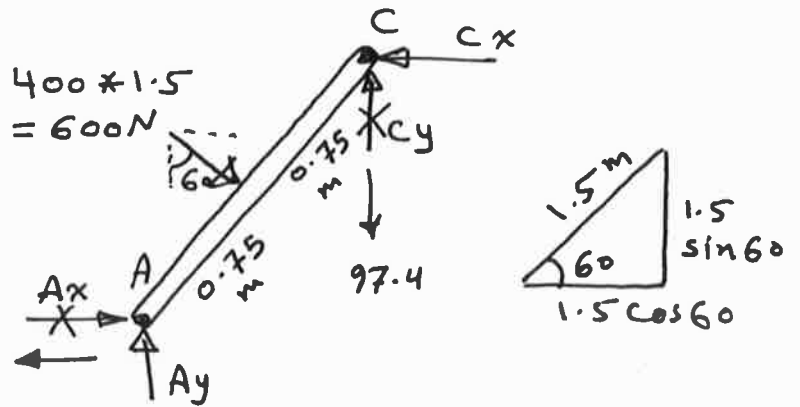

FBD (BC) :

$$\sum M_B = 0 : C_x (1) - C_y (1) - 500 (1) = 0 \quad \text{--- ②}$$

Solve ① & ② $\Rightarrow C_x = 402.6 \text{ N}$

$C_y = -97.4$ (correct the direction)

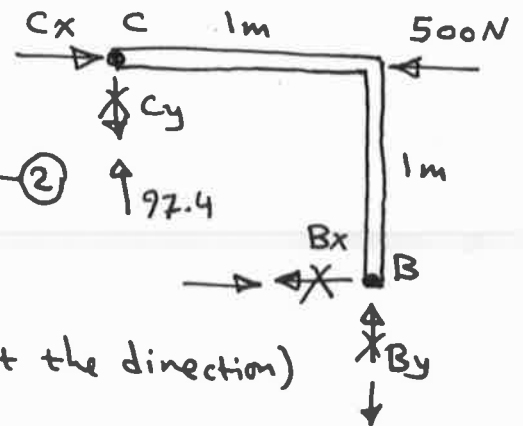

$$\sum F_x = 0 \Rightarrow 402.6 - 500 - B_x = 0 \Rightarrow B_x = -97.4 = 97.4 \text{ N} \rightarrow$$

$$\sum F_y = 0 \Rightarrow 97.4 + B_y = 0 \Rightarrow B_y = -97.4 = 97.4 \text{ N} \downarrow$$

FBD (AC) :

$$\sum F_x = 0 \Rightarrow A_x + 600 \sin 60 - 402.6 = 0 \Rightarrow A_x = -117 = 117 \text{ N} \leftarrow$$

$$\sum F_y = 0 \Rightarrow A_y - 600 \cos 60 - 97.4 = 0 \Rightarrow A_y = 397 \text{ N} \uparrow$$

Ex.10 :

The pin B will safely support a force of 24 kN. What is the largest mass M that the pin B will safely support ?

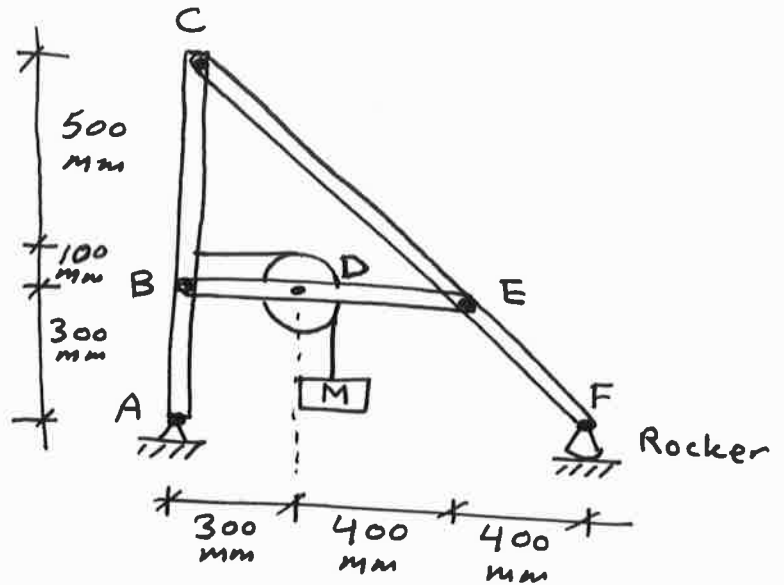

Sol. $W = M * g = 9.81 M$

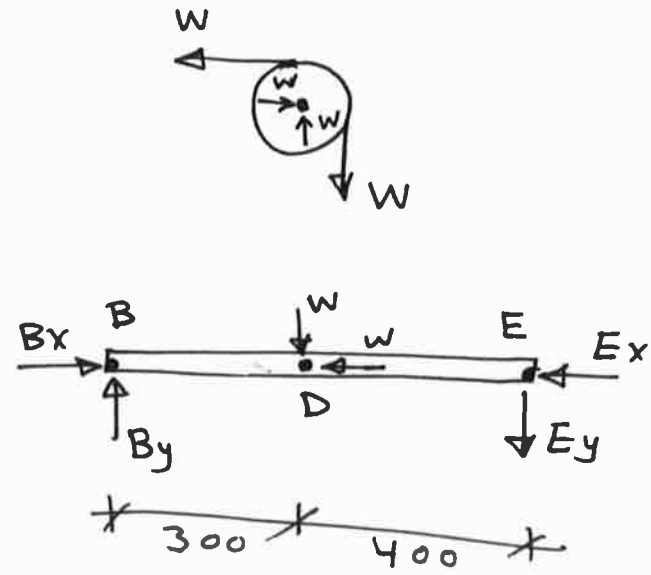
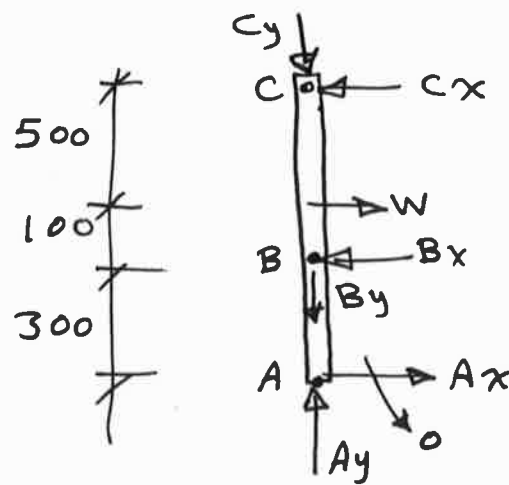

FBD (BDE):

$$\sum M_E = 0 \Rightarrow By(700) - W(400) = 0 \Rightarrow By = \frac{4}{7} W$$

Entire Frame:

$$\sum F_x = 0 \Rightarrow Ax = 0$$

FBD(ABC):

$$\sum M_c = 0 \Rightarrow Bx(600) - W(500) = 0 \Rightarrow Bx = \frac{5}{6} W$$

Now: $R_B = \sqrt{(By)^2 + (Bx)^2} = \sqrt{(\frac{4}{7}W)^2 + (\frac{5}{6}W)^2} = 1.0104 W$

$$24 \text{ kN} = 1.0104 W \Rightarrow W = 23.752 \text{ kN} = 23752 \text{ N}$$

$$W = 9.81 M \Rightarrow M = 23752 / 9.81 = \boxed{2421.2 \text{ kg}}$$

Ex. 11 :

Determine the reactions at A, B, and C.

(There is a hinge (Pin) at point D).

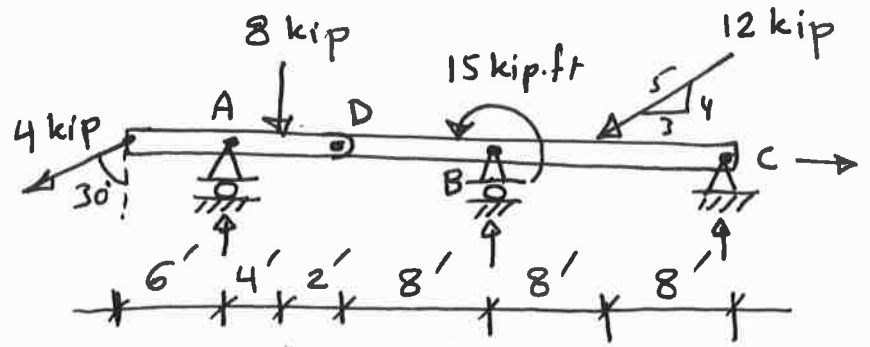
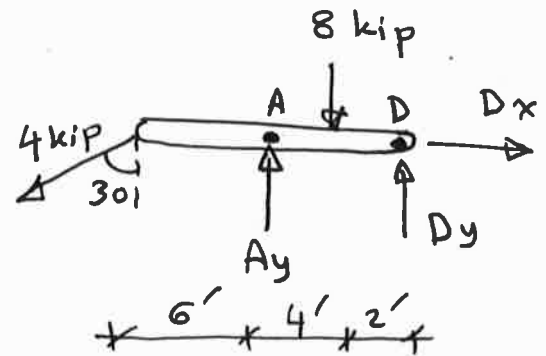
Sol.FBD (AD):

$$\sum M_D = 0$$

$$-4 \cos 30 (12) + A_y (6) - 8(2) = 0$$

$$\Rightarrow A_y = 9.595 \text{ kip } \uparrow$$

Entire beam :

$$\sum M_C = 0$$

$$-4 \cos 30 (36) + 9.595 (30) - 8(26) - 15 + B_y (16)$$

$$- 12 \left(\frac{4}{5}\right)(8) = 0$$

$$\Rightarrow B_y = 8.541 \text{ kip } \uparrow$$

$$\sum F_y = 0$$

$$-4 \cos 30 + 9.595 - 8 + 8.541 - 12 \left(\frac{4}{5}\right) + C_y = 0$$

$$\Rightarrow C_y = 2.928 \text{ kip } \uparrow$$

$$\sum F_x = 0$$

$$-4 \sin 30 - 12 \left(\frac{3}{5}\right) + C_x = 0 \Rightarrow C_x = 9.2 \text{ kip } \rightarrow$$

Ex.12 :

For the wall crane shown in the figure, find the reactions at A and D. Also find the force in the cable of the winch.

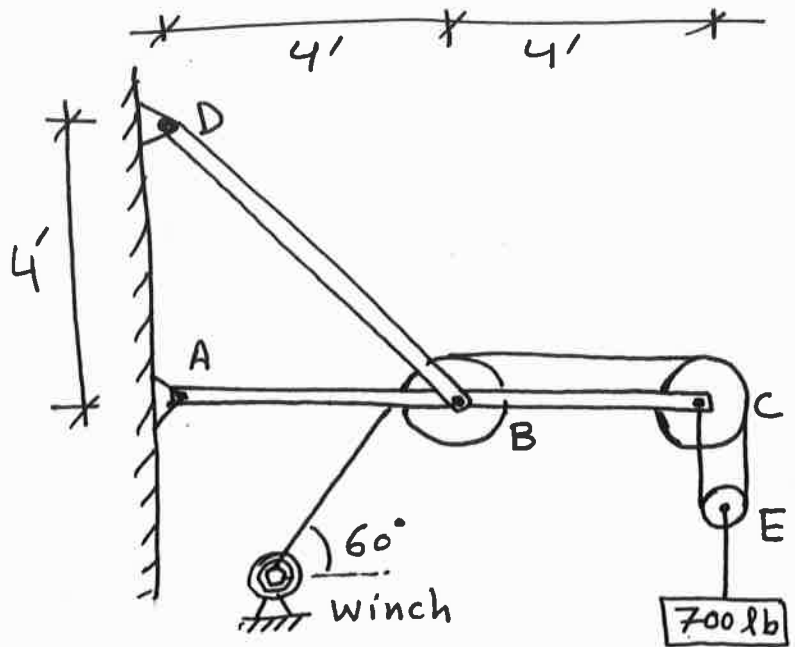

Sol.

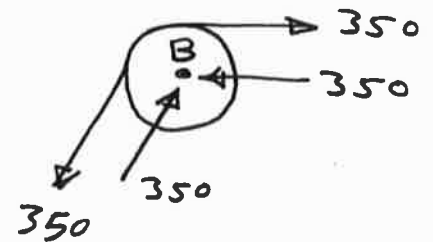
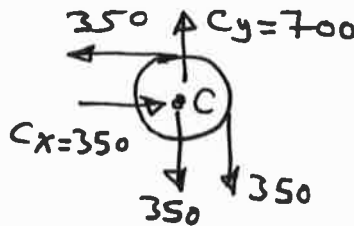
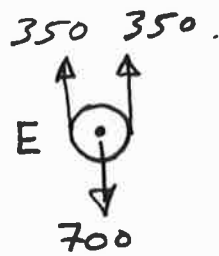

FBD (ABC): BD is two force member.

$$\sum M_A = 0$$

$$-F_{BD} \left(\frac{1}{\sqrt{2}}\right)(4) + 350 \sin 60(4) + 700(8) = 0 \Rightarrow F_{BD} = 2408.56 \text{ lb}$$

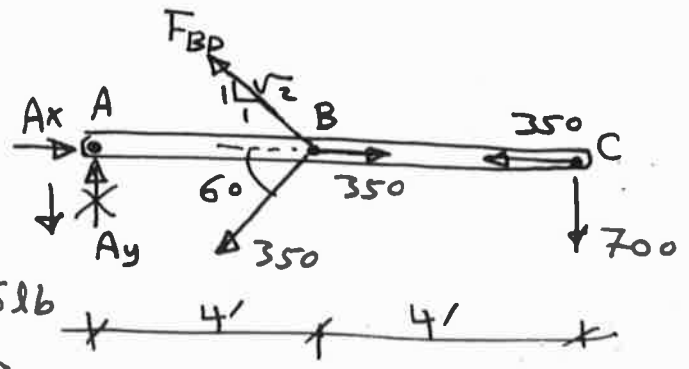

$$\sum F_y = 0$$

$$A_y + 2408.56 \left(\frac{1}{\sqrt{2}}\right) - 700 - 350 \sin 60 = 0$$

$$\Rightarrow A_y = -700 = 700 \text{ lb } \downarrow$$

$$\sum F_x = 0$$

$$A_x - 2408.56 \left(\frac{1}{\sqrt{2}}\right) - 350 \cos 60 + 350 - 350 = 0$$

$$\Rightarrow A_x = 1878.11 \text{ lb } \rightarrow$$

FBD (D):

$$D_x = 2408.56 \left(\frac{1}{\sqrt{2}}\right) = 1703.11 \text{ lb } \leftarrow$$

$$D_y = 2408.56 \left(\frac{1}{\sqrt{2}}\right) = 1703.11 \text{ lb } \uparrow$$

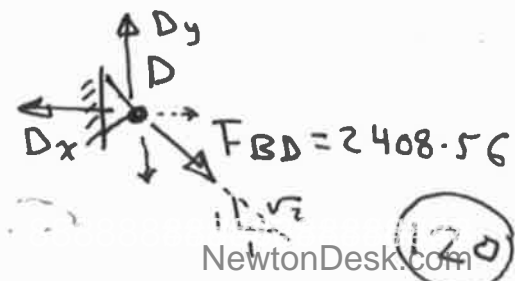

Ex. 13 :

The engine hoist is used to support the 200kg engine. Determine the force acting in the hydraulic cylinder AB, the horizontal and vertical components of the force at the pin C, and the reactions at the fixed support D.

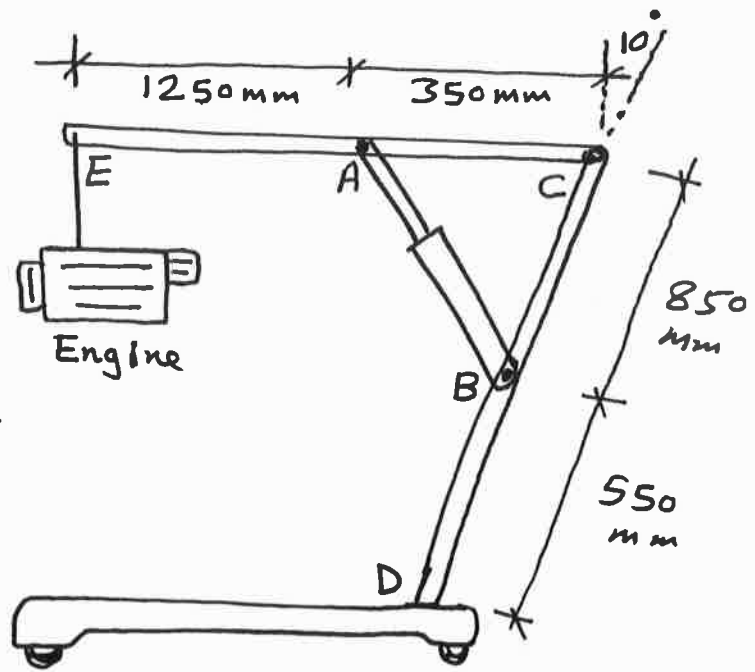

Sol. AB is two force member.

$$d = \sqrt{350^2 + 850^2 - 2(350)(850)\cos 80}$$

$$= 861.21 \text{ mm}$$

$$\frac{\sin \theta}{850} = \frac{\sin 80}{861.21} \Rightarrow \theta = 76.41^\circ$$

FBD (EAC) :

$$\sum M_C = 0$$

$$-1962(1.6) + F_{AB} \sin 76.41(0.35) = 0$$

$$\Rightarrow F_{AB} = 9227.60 \text{ N}$$

$$\sum F_x = 0 \Rightarrow C_x - 9227.60 \cos 76.41 = 0 \Rightarrow C_x = 2168.65 \text{ N}$$

$$\sum F_y = 0 \Rightarrow -C_y - 1962 + 9227.60 \sin 76.41 = 0 \Rightarrow C_y = 7007.14 \text{ N}$$

FBD (Entire) :

$$\sum F_x = 0 \Rightarrow D_x = 0$$

$$\sum F_y = 0 \Rightarrow D_y = 1962 \text{ N}$$

$$\sum M_D = 0 \Rightarrow M_D - 1962(1.6 - 1.4 \sin 10) = 0$$

$$\Rightarrow M_D = 2662.22 \text{ N}\cdot\text{m}$$

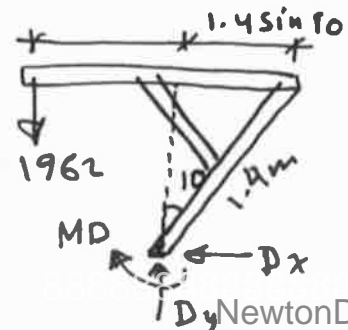
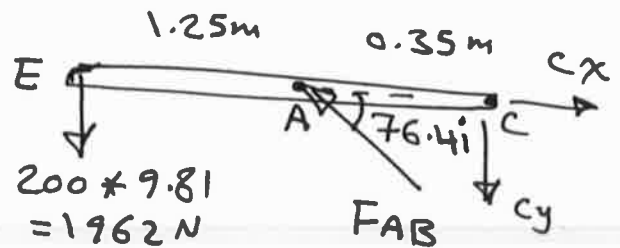
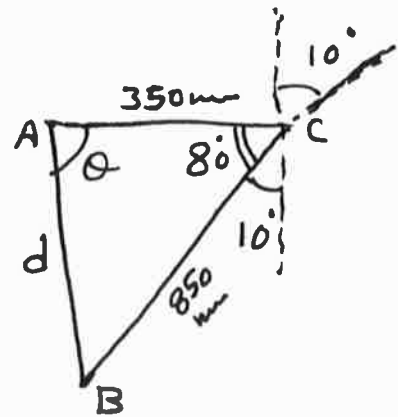

CENTROID

The centroid is a point which defines the geometric center of an object.

The lines, areas, and volumes all have centroids.

Here, we will study the centroid of area only.

Centroid of Area:

The centroid of area is represented by the coordinates (\bar{x}, \bar{y}) measured from a reference axes x and y .

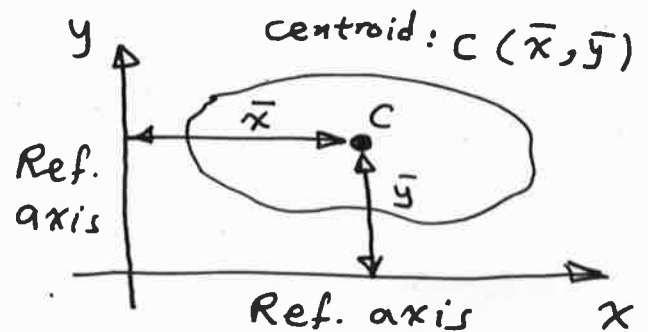

For a general case of area, the centroid is determined as follows:

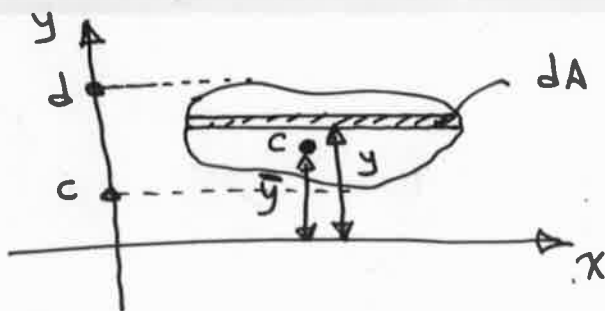

Take a horizontal strip
 Moment of area = Σ Moments of strips
 $A \cdot \bar{y} = \int dA \cdot y$

$$\Rightarrow \bar{y} = \frac{\int y dA}{A}$$

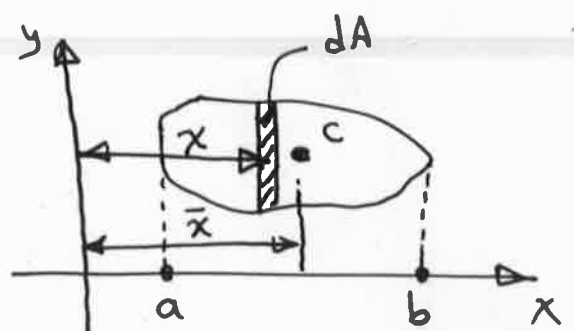

Take a vertical strip
 Moment of area = Σ Moments of strips
 $A \cdot \bar{x} = \int dA \cdot x$

$$\Rightarrow \bar{x} = \frac{\int x dA}{A}$$

Symmetric Area:

When the area has an axis of symmetry, the centroid of the area will lie along the axis of the symmetry.

When the area has two or more than two axes of symmetry, the centroid will lie at the intersection of these axes.

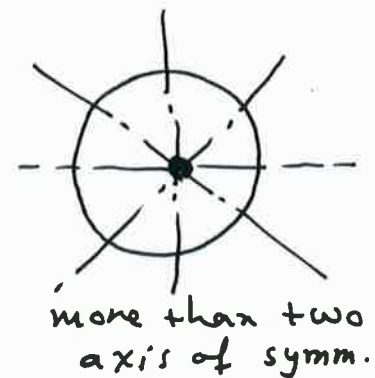
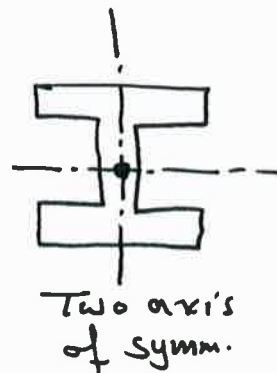
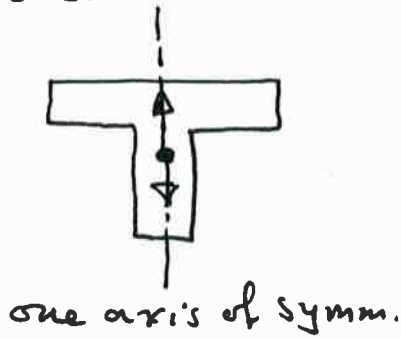

Ex.1 Locate the centroid of the shaded area shown:

Sol. $\bar{x} = \frac{\int x dA}{A}$, $\bar{y} = \frac{\int y dA}{A}$

For \bar{x} :

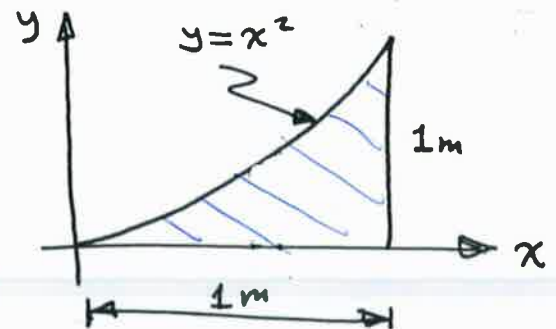
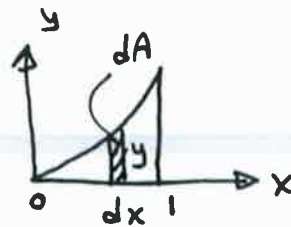

$$\int x dA = \int x \cdot y \cdot dx$$

$$= \int x \cdot x^2 \cdot dx = \int_0^1 x^3 dx = \frac{1}{4} [x^4]_0^1 = \frac{1}{4}$$

$$A = \int y dx = \int_0^1 x^2 dx = \frac{1}{3} [x^3]_0^1 = \frac{1}{3}$$

$$\Rightarrow \bar{x} = \frac{\int x dA}{A} = \frac{1/4}{1/3} = \frac{3}{4} \text{ m} = 0.75 \text{ m}$$

For \bar{y} :

$$dA = (1-x) dy, \quad x = y^{1/2}$$

$$\Rightarrow dA = (1 - y^{1/2}) dy$$

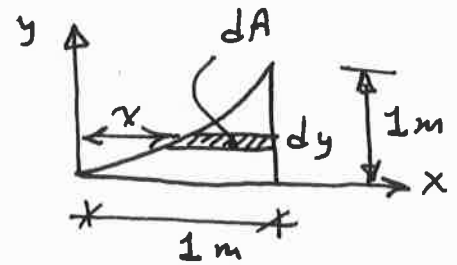

$$\int y dA = \int y (1 - y^{1/2}) dy = \int_0^1 (y - y^{3/2}) dy = \left[\frac{y^2}{2} - \frac{2}{5} y^{5/2} \right]_0^1$$

$$= \frac{1}{2} - \frac{2}{5} = \frac{1}{10}$$

$$A = \int_0^1 (1-x) dy = \int_0^1 (1 - y^{1/2}) dy$$

$$= \left[y - \frac{2}{3} y^{3/2} \right]_0^1$$

$$= 1 - \frac{2}{3} = \frac{1}{3}$$

$$\Rightarrow \bar{y} = \frac{\int y dA}{A} = \frac{1/10}{1/3} = \frac{3}{10} = 0.3 \text{ m}$$

\Rightarrow the centroid of the area is $(0.75 \text{ m}, 0.3 \text{ m})$

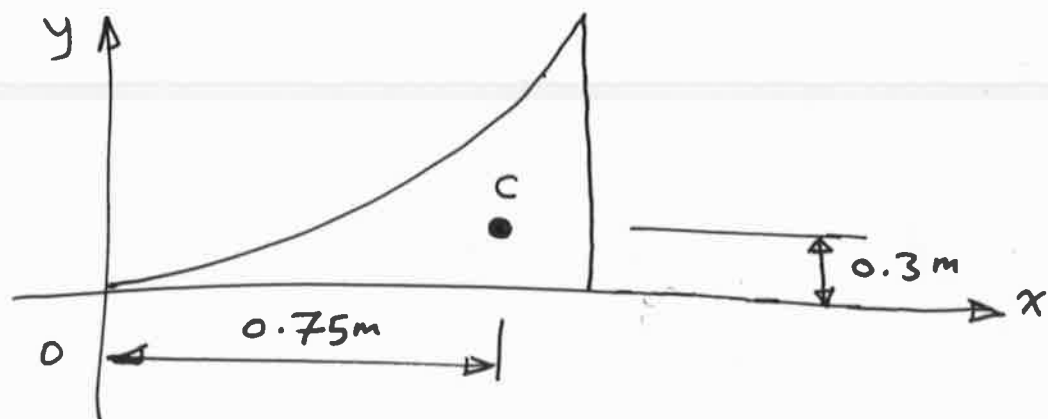

Ex.2: Locate \bar{x} for the shaded area:

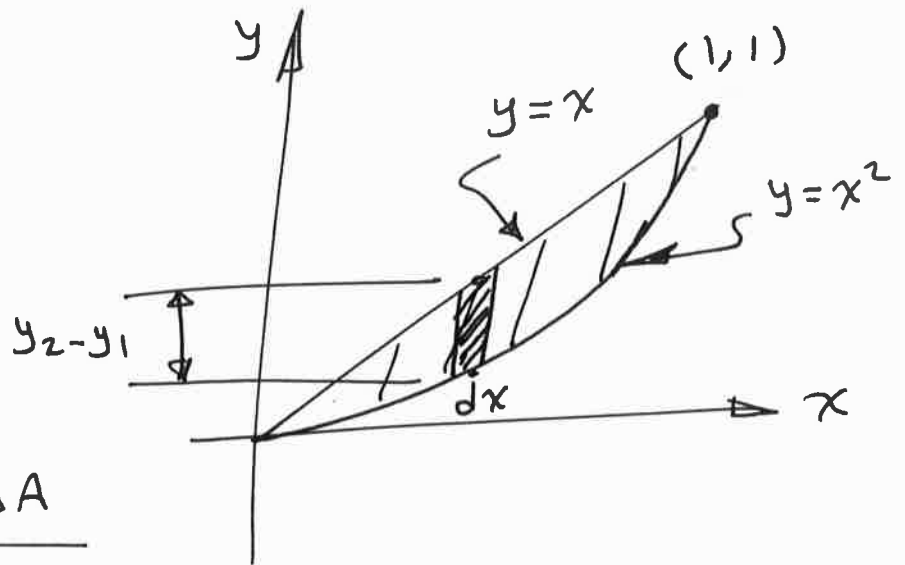

Sol. $\bar{x} = \frac{\int x dA}{A}$

$$dA = (y_2 - y_1) dx = (x - x^2) dx$$

$$\Rightarrow \int x dA = \int_0^1 x(x - x^2) dx$$

$$= \int_0^1 (x^2 - x^3) dx = \left[\frac{x^3}{3} - \frac{x^4}{4} \right]_0^1$$

$$= \frac{1}{3} - \frac{1}{4} = \frac{1}{12}$$

$$A = \int_0^1 (y_2 - y_1) dx = \int_0^1 (x - x^2) dx$$

$$= \left[\frac{x^2}{2} - \frac{x^3}{3} \right]_0^1 = \frac{1}{2} - \frac{1}{3} = \frac{1}{6}$$

$$\Rightarrow \bar{x} = \frac{1/12}{1/6} = \frac{1}{2} = 0.5$$

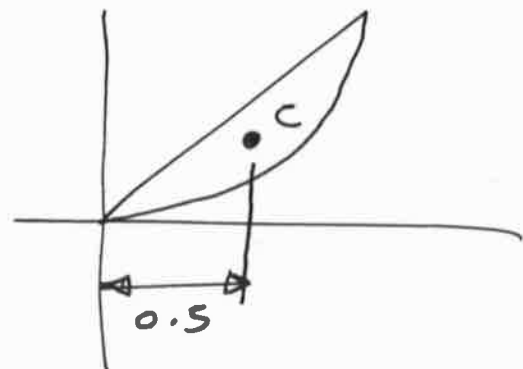

Centroid of composite areas:

The centroid of composite areas can be found using the relations:—

$$\bar{x} = \frac{\sum xA}{\sum A}$$

$$\bar{y} = \frac{\sum yA}{\sum A}$$

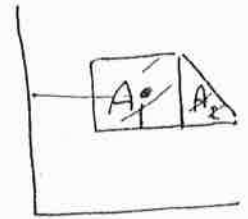

where:

x, y : centroids of each composite part of the area.

$\sum A$: sum of the areas of all parts (total area).

\bar{x}, \bar{y} : Centroids of the total area.

Centroids for common shapes of areas are given in the table below:



Shape

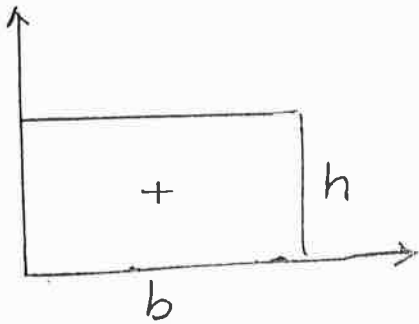

$$\bar{x} = \frac{b}{2}, \bar{y} = \frac{h}{2}$$

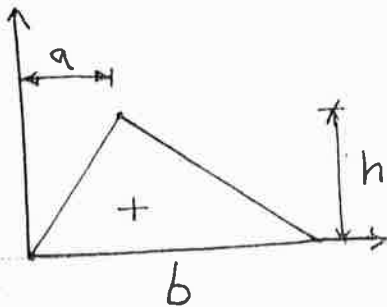

$$\bar{x} = \frac{a+b}{3}, \bar{y} = \frac{h}{3}$$

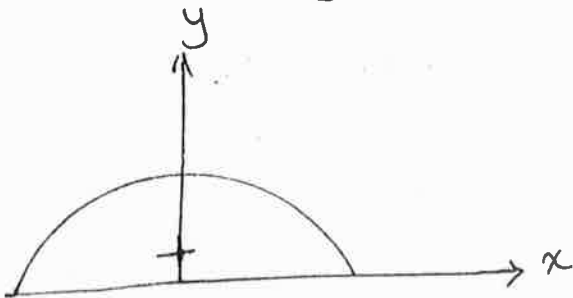

$$\bar{x} = 0, \bar{y} = \frac{4r}{3\pi} = 0.424r$$

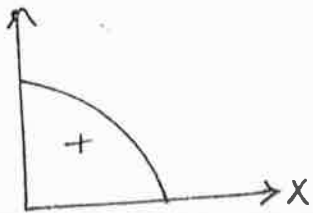

$$\bar{x} = 0.424r, \bar{y} = 0.424r$$

Section

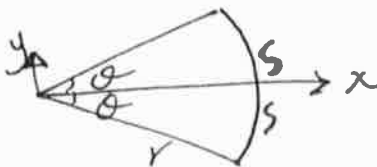

$$A = r^2 \theta$$

from $A = \frac{1}{2} r s$ & $s = r \theta$

$$\Rightarrow A = \frac{1}{2} r^2 \theta \text{ (for each sector)}$$

$$\bar{x} = \frac{2}{3} \frac{r \sin \theta}{\theta}, \bar{y} = 0$$

θ (in radians)

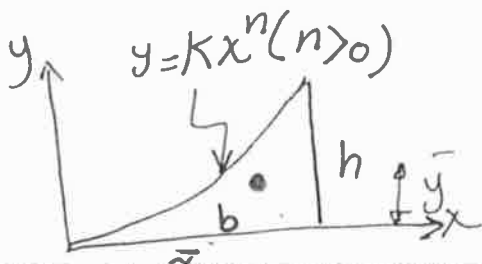

$$A = \frac{1}{n+1} bh$$

$$\bar{x} = \frac{n+1}{n+2} b, \bar{y} = \frac{n+1}{4n+2} h$$

Ex 1. Locate the centroid of the plate shown:

Sol: The plate is divided into three segments:

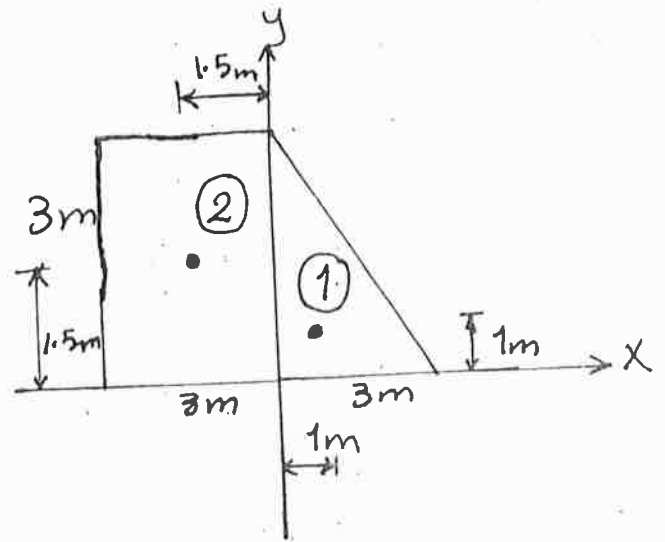
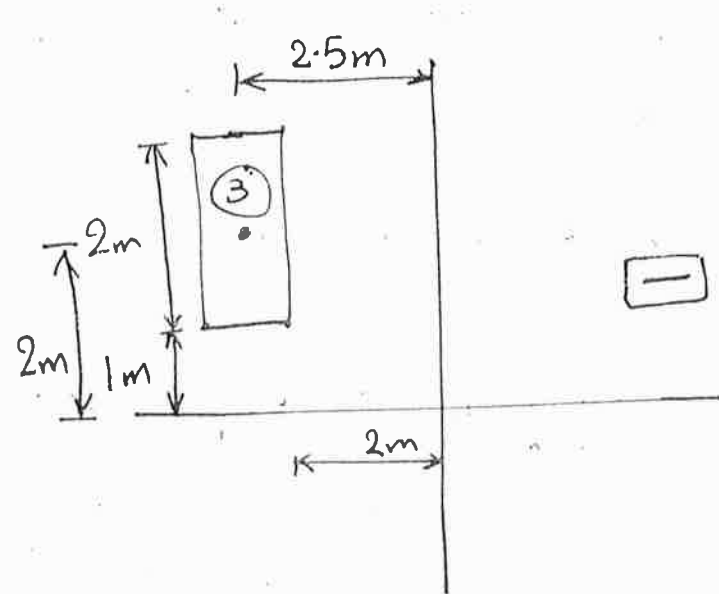
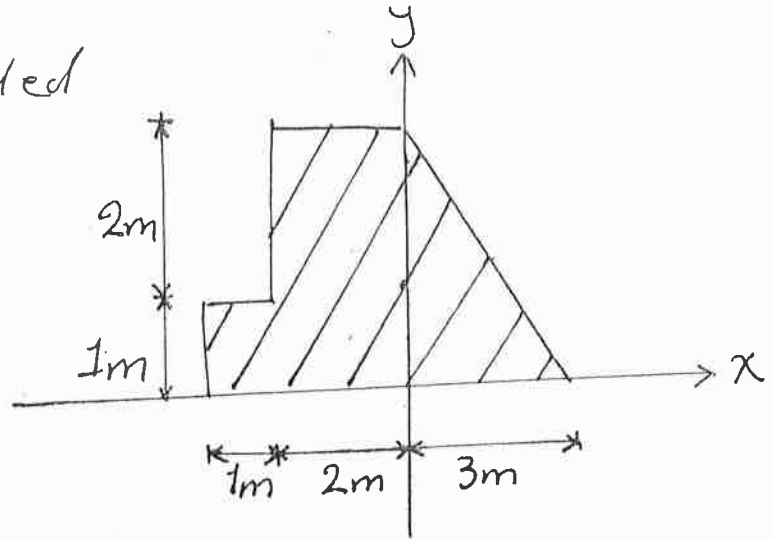

segment	A	\bar{x}	\bar{y}	$A \cdot \bar{x}$	$A \cdot \bar{y}$
(1)	$\frac{1}{2}(3)(3) = 4.5$	1	1	4.5	4.5
(2)	$3(3) = 9$	-1.5	1.5	-13.5	13.5
(3)	$-2(1) = -2$	-2.5	2	5	-4
	$\boxed{\sum A = 11.5}$			$\boxed{\sum A \cdot \bar{x} = -4}$	$\boxed{\sum A \cdot \bar{y} = 14}$

$$\bar{x} = \frac{\sum A \cdot \bar{x}}{\sum A} = \frac{-4}{11.5} = -0.348 \text{ m}$$

$$\bar{y} = \frac{\sum A \cdot \bar{y}}{\sum A} = \frac{14}{11.5} = 1.22 \text{ m}$$

Ex. 2: Locate the centroid?

sol:

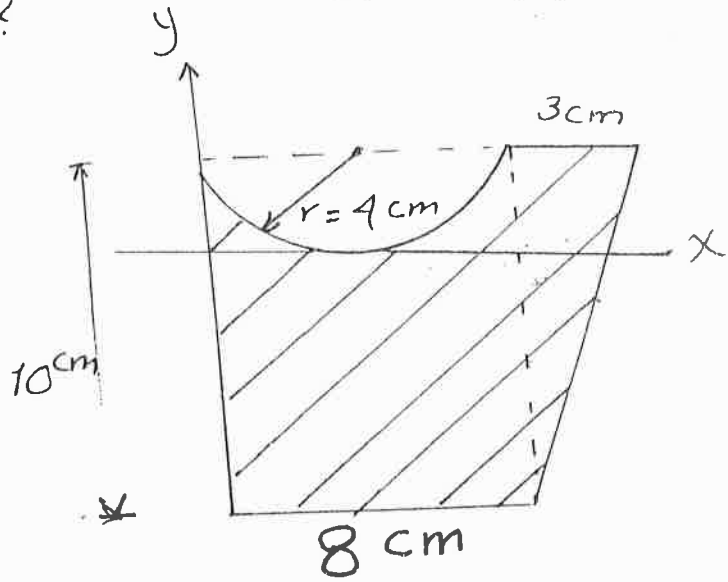
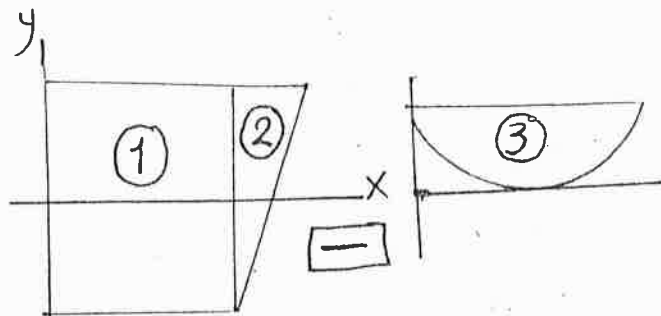

segment	A	x	y	A · x	A · y
①	8 × 10 = 80	4	-1	320	-80
②	$\frac{1}{2}(3)(10) = 15$	9	$4 - \frac{10}{3} = 0.667$	135	10
③	$-\frac{\pi(4)^2}{2} = -25.13$	4	$4 - 0.424(4) = 2.304$	-100.52	-57.8
	$\Sigma A = 69.87$			$\Sigma A \cdot x = 354.48$	$\Sigma A \cdot y = -127.8$

$$\Rightarrow \bar{x} = \frac{354.48}{69.87} = 5.07 \text{ cm}$$

$$\bar{y} = \frac{-127.8}{69.87} = -1.829 \text{ cm}$$

Direct Solution:

$$\bar{x} = \frac{(8 \times 10)(4) + (0.5 \times 3 \times 10)(8 + \frac{3}{3}) - (0.5\pi(4)^2)(4)}{(8 \times 10) + (0.5 \times 3 \times 10) - (0.5\pi(4)^2)} = 5.07 \text{ cm}$$

$$\bar{y} = \frac{(8 \times 10)(-1) + (0.5 \times 3 \times 10)(4 - \frac{10}{3}) - (0.5\pi(4)^2)(4 - 0.424(4))}{(8 \times 10) + (0.5 \times 3 \times 10) - (0.5\pi(4)^2)} = -1.829 \text{ cm}$$

Ex. 3 Locate the centroid (\bar{y}) of the cross sectional area of the beam.

Sol:

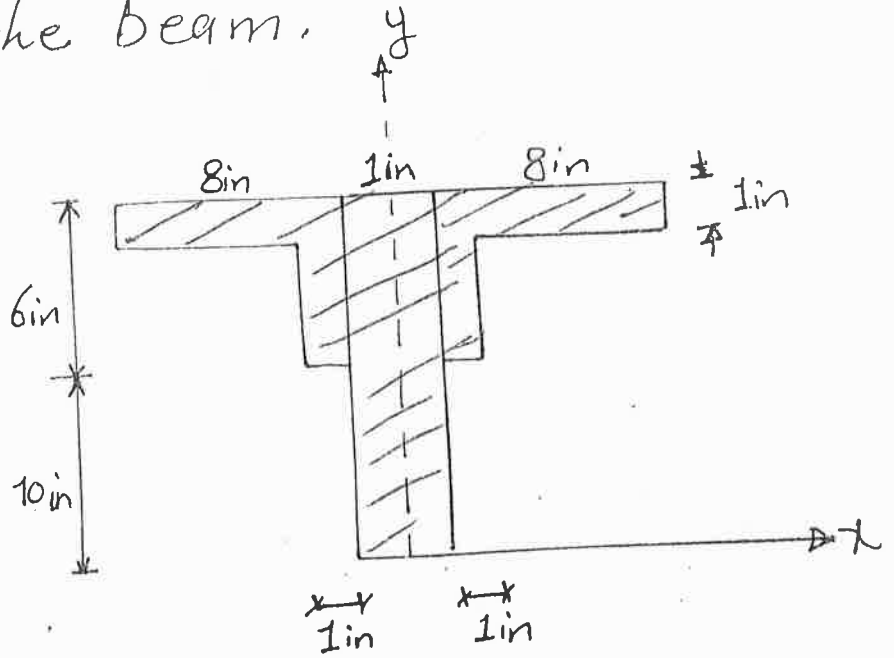
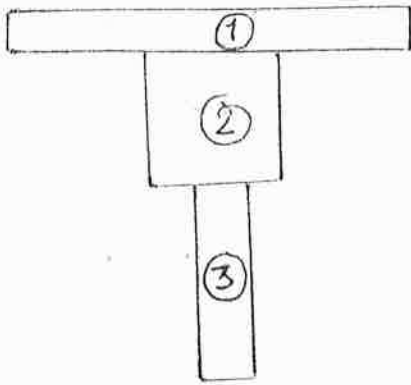

<u>Segment</u>	<u>A</u>	<u>y</u>	<u>A · y</u>
①	$17 * 1 = 17$	15.5	263.5
②	$5 * 3 = 15$	12.5	187.5
③	$10 * 1 = 10$	5	50
	<u>$\sum A = 42$</u>		<u>$\sum A \cdot y = 501$</u>

$$\Rightarrow \bar{y} = \frac{501}{42} = 11.9 \text{ in}$$

or directly:

$$\bar{y} = \frac{(17 * 1)(15.5) + (5 * 3)(12.5) + (10 * 1)(5)}{(17 * 1) + (5 * 3) + (10 * 1)} = 11.9 \text{ in.}$$

130

Ex 4: Determine \bar{x}

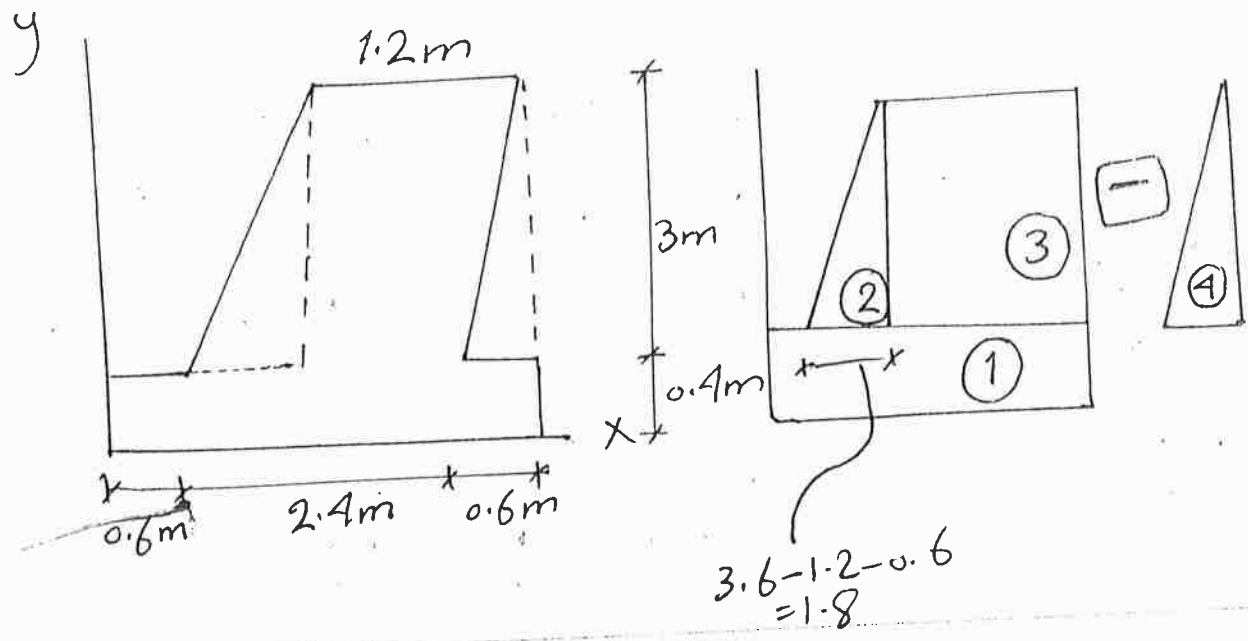

Seg.	A	x	A · x
①	$0.4 \times 3.6 = 1.44$	1.8	2.592
②	$\frac{1.8 \times 3}{2} = 2.7$	$2(\frac{1.8}{3}) + 0.6 = 1.8$	4.86
③	$1.2 \times 3 = 3.6$	$0.6 + 2.4 = 3$	10.8
④	$-\frac{1}{2}(0.6)(3) = -0.9$	$3.6 - \frac{0.6}{3} = 3.4$	-3.06
$\Sigma A = 6.84$			$\Sigma A \cdot x = 15.192$

$$\Rightarrow \bar{x} = \frac{15.192}{6.84} = 2.22 \text{ m}$$

Directly:

$$\bar{x} = \frac{(0.4 \times 3.6)(1.8) + (0.5 \times 1.8 \times 3)(0.6 + \frac{2}{3}(1.8)) + (1.2 \times 3)(2.4 + \frac{1.2}{2}) - (0.5 \times 0.6 \times 3)(3.6 - \frac{0.6}{3})}{(0.4 \times 3.6) + (0.5 \times 1.8 \times 3) + (1.2 \times 3) - (0.5 \times 0.6 \times 3)}$$

= 2.22 m

Ex 5: Locate the centroid:

sol: due to symmetry, $\bar{x} = 0$

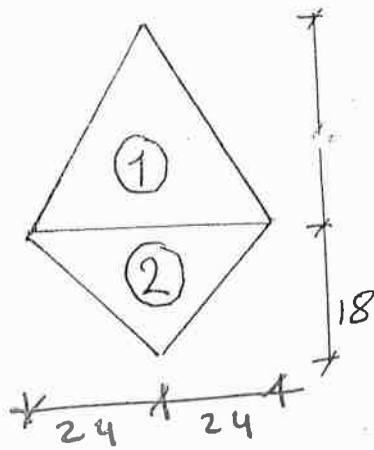

32

□

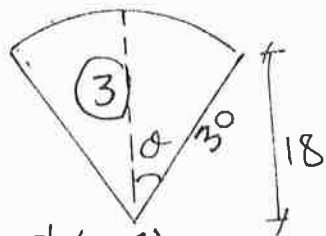

$$\theta = \tan^{-1}\left(\frac{24}{18}\right)$$

$$\theta = 53.13^\circ$$

$$53.13 \times \frac{\pi}{180} = 0.927 \text{ rad.}$$

$$\sin \theta = 0.8$$

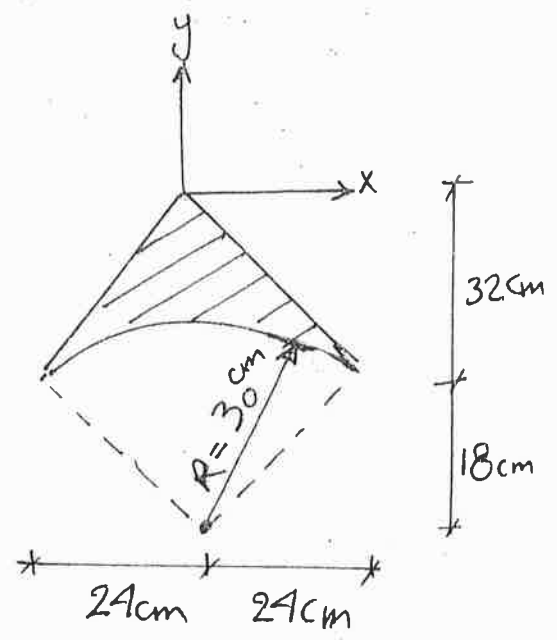

Seg.	A	y	A · y
①	$\frac{1}{2}(48)(32) = 768$	$-\frac{2}{3}(32) = -21.33$	-16381.11
②	$\frac{1}{2}(48)(18) = 432$	$-(32 + \frac{1}{3}(18)) = -38$	-16416
③	$\frac{(30)^2}{r^2} \times \theta = 834.3$	$(50 - \frac{2}{3} \times \frac{30 \times 0.8}{0.927}) = -32.74$	27314.982

$$\Sigma A = 365.7$$

$$\Sigma A \cdot y = -5482.458$$

$$\bar{y} = \frac{-5482.458}{365.7} = -14.99 \text{ cm}$$

$$\approx -15 \text{ cm}$$

H.W.1 An engineer wants to estimate the effect of wind loads and he needs the area and centroid. Determine the area and centroid for the wall.

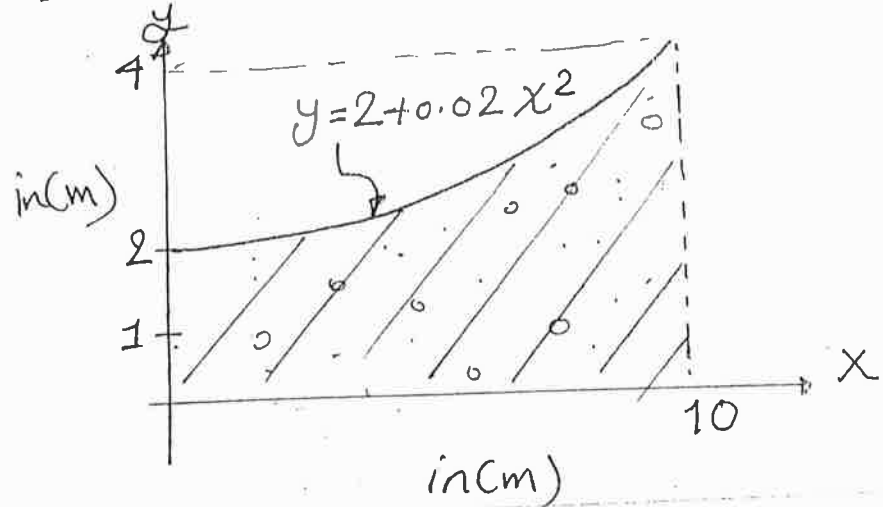

Ans.

$$A = 26.67 \text{ m}^2$$

$$\bar{x} = 5.62 \text{ m}$$

$$\bar{y} = 1.4 \text{ m}$$

H.W.2 $\bar{x} = ?$

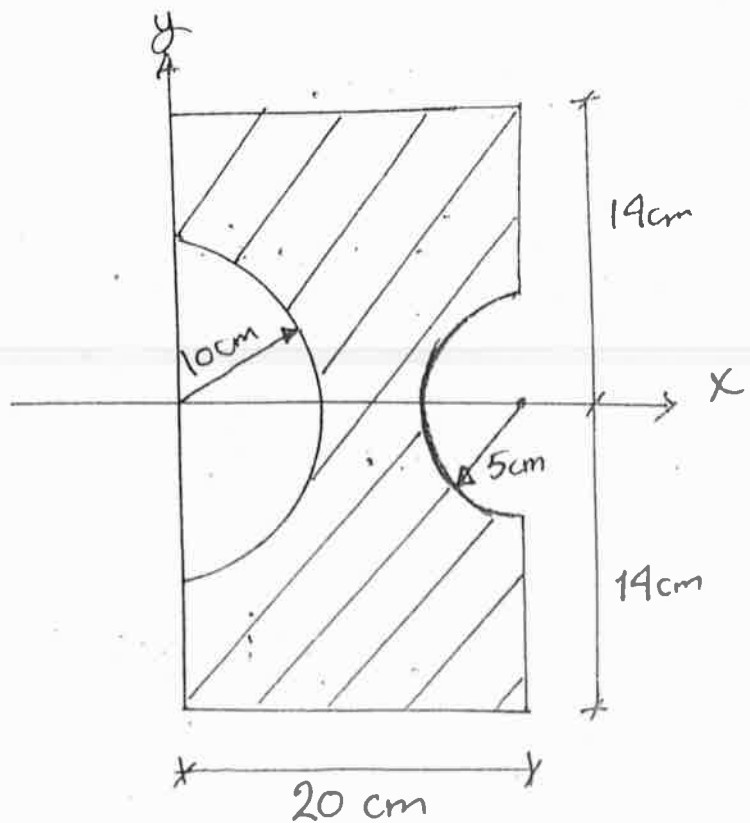

Ans.

$$\bar{x} = 11.6 \text{ cm}$$

THE MOMENTS OF INERTIA FOR AREAS:

The inertia is the resistance of any object to a change

The moment of inertia is a measure of an object's resistance to its rotation.

The moment of inertia for an area is an important property in analysis and design of structural members.

The centroid represents the first moment of area ($\int x \, dA$), while the moment of inertia of area represents the second moment of area ($\int x^2 \, dA$).

Consider the figure.

The moment of inertia of the area about (x) & (y) axes are:

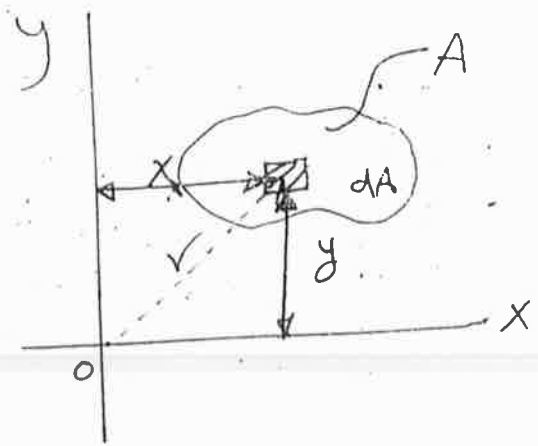

$$I_x = \int y^2 \, dA \quad , \quad I_y = \int x^2 \, dA$$

The polar moment of inertia J_o is

$$J_o = \int r^2 \, dA$$

The relation with I_x & I_y is $J_o = I_x + I_y$

$$[\text{From } r^2 = x^2 + y^2]$$

The moment of inertia is always positive [product of distance squared & area], and the units are length raised to the fourth power, eg., m^4 , mm^4 , in^4 , ... etc.

Parallel Axis Theorem For an Area:

This theorem is used to find the moment of inertia about an axis parallel to axis passing through the centroid.

This theorem says:

$$I_x = I_{\bar{x}} + A d_y^2$$

$$I_y = I_{\bar{y}} + A d_x^2$$

$$J_o = J_c + A d^2$$

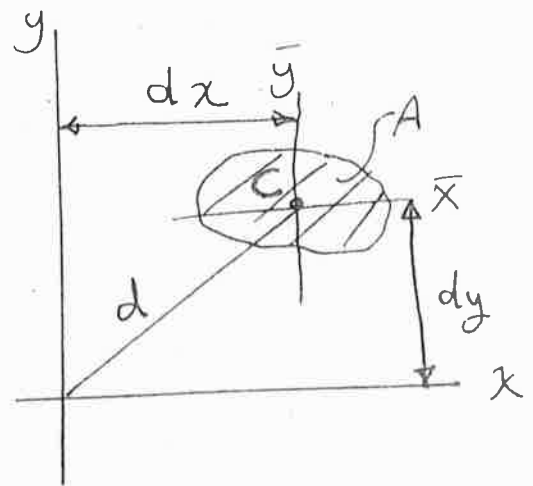

Radius of Gyration of an Area:

The radius of Gyration is often used in design of columns. The formulas are:

$$k_x = \sqrt{\frac{I_x}{A}}, \quad k_y = \sqrt{\frac{I_y}{A}}, \quad k_o = \sqrt{\frac{J_o}{A}}$$

Moment of inertia by integration:

Ex1: Determine the moment of inertia for the rectangular area with respect to (a) the centroidal \bar{x} axis. (b) the axis x_b passing through the base of rectangle. (c) the \bar{z} axis perpendicular to \bar{x} - \bar{y} plane and passing through C.

Sol.

$$(a) \quad I_{\bar{x}} = \int \bar{y}^2 dA$$

$$dA = b dy$$

$$I_{\bar{x}} = \int_{-h/2}^{h/2} (\bar{y})^2 b dy$$

$$= b \int_{-h/2}^{h/2} (\bar{y})^2 dy = b \left[\frac{\bar{y}^3}{3} \right]_{-h/2}^{h/2}$$

$$= \frac{b}{3} \left[\frac{h^3}{8} - \frac{-h^3}{8} \right] = \frac{1}{12} bh^3$$

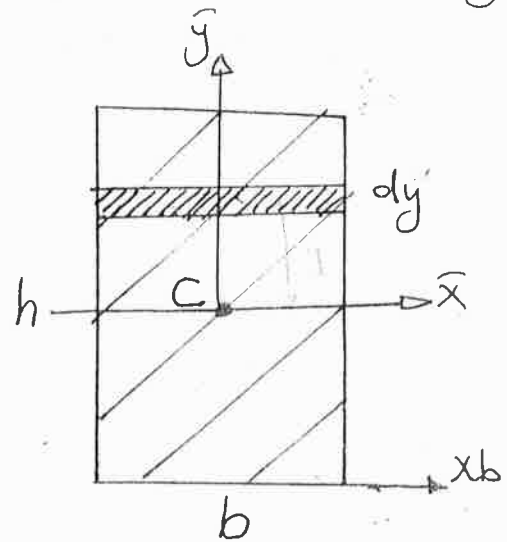

$$(b) \quad I_{x_b} = I_{\bar{x}} + Ad^2$$

$$= \frac{1}{12} bh^3 + bh \left(\frac{h}{2} \right)^2 = \frac{1}{3} bh^3$$

$$(c) \quad J_c = I_{\bar{x}} + I_{\bar{y}} \quad , \quad I_{\bar{y}} = \frac{1}{12} hb^3$$

$$\downarrow$$

$$\text{or } I_{\bar{z}} = \frac{1}{12} bh^3 + \frac{1}{12} hb^3 = \frac{1}{12} bh(h^2 + b^2)$$

Ex 2: Determine moment of inertia of the shaded area and about x-axis.

Sol: $I_x = \int y^2 \cdot dA$

$$dA = (100 - x) dy$$

$$= \left(100 - \frac{y^2}{400}\right) dy$$

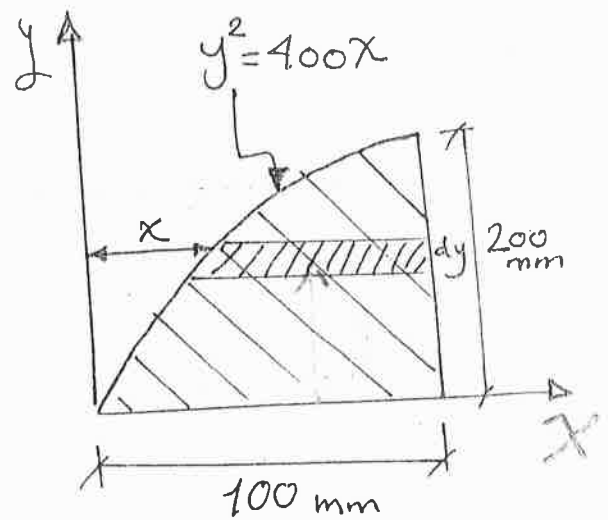

$$I_x = \int_0^{200} y^2 \left(100 - \frac{y^2}{400}\right) dy$$

$$= \int_0^{200} \left(100y^2 - \frac{1}{400} y^4\right) dy$$

$$= 107 * 10^6 \text{ mm}^4$$

Ex 3: Find the M.O.I. with respect to X-axis:

Sol: $I_x = \int y^2 \cdot dA$

$$dA = 2x dy$$

$$dA = 2\sqrt{a^2 - y^2} dy$$

$$I_x = \int_{-a}^a y^2 (2\sqrt{a^2 - y^2}) dy$$

$$I_x = \frac{\pi a^4}{4}$$

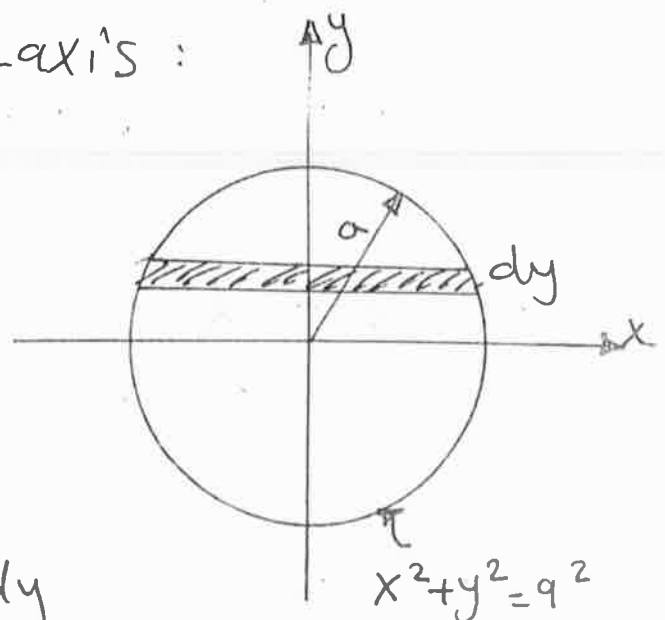

Moment of Inertia for Composite Areas:

The following procedure provides a method for determining the M.O.I of a composite area about a reference axis.

1. Divide the area into its composite parts and indicate the perpendicular distance from the centroid of each part to the reference axis.

2. Find the M.O.I of each part about its centroidal axis (use the table of M.O.I).

If the centroidal axis does not coincide with the reference axis, use the parallel axis theorem

$$I = \bar{I} + Ad^2$$

3. The M.O.I of the total area about the reference axis is determined by summing the results of parts.

M.O.I for Common shape:

Shape	M.O.I
	$I_{\bar{x}} = \frac{bh^3}{12}$ $I_x = \frac{bh^3}{3}$
	$I_{\bar{x}} = \frac{bh^3}{36}$ $I_x = \frac{bh^3}{12}$
	$I_{\bar{x}} = \frac{\pi r^4}{4}$ $I_{\bar{y}} = \frac{\pi r^4}{4}$
	$I_{\bar{x}} = 0.11 r^4$ $I_{\bar{y}} = \frac{1}{8} \pi r^4$ $I_x = \frac{1}{8} \pi r^4$
	$I_x = \frac{1}{16} \pi r^4$ $I_{\bar{y}} = \frac{1}{16} \pi r^4$ $I_{\bar{x}} = 0.055 r^4$ $I_{\bar{y}} = 0.055 r^4$

Ex1: Find M.O.I about x-axis:

Sol:

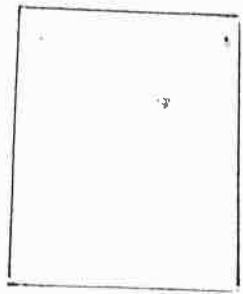

-

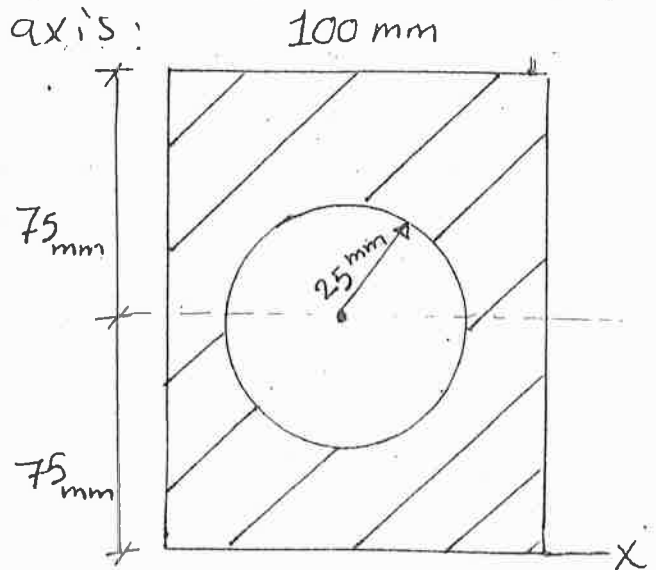
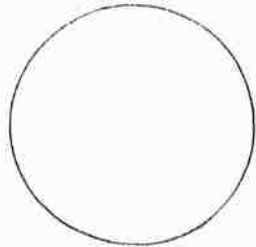

Circle: $I_x = I_{\bar{x}} + Ad^2$

$$= \frac{\pi(25)^4}{4} + \pi(25)^2(75)^2 = 11.4 \times 10^6 \text{ mm}^4$$

rectangle: $I_x = I_{\bar{x}} + Ad^2$

$$= \frac{100(150)^3}{12} + (100)(150)(75)^2$$

$$= 112.5 \times 10^6 \text{ mm}^4$$

\Rightarrow M.O.I for composite Area

$$= 112.5 \times 10^6 - 11.4 \times 10^6$$

$$\text{M.O.I} = 101.1 \times 10^6 \text{ mm}^4$$

Ex 2: Find I_x & K_x .

sol:

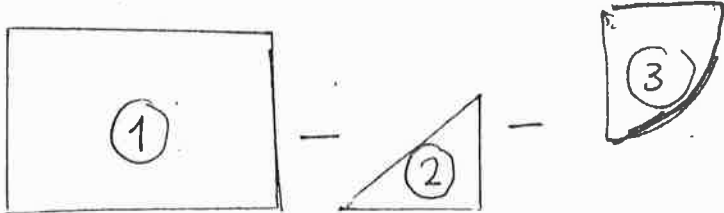
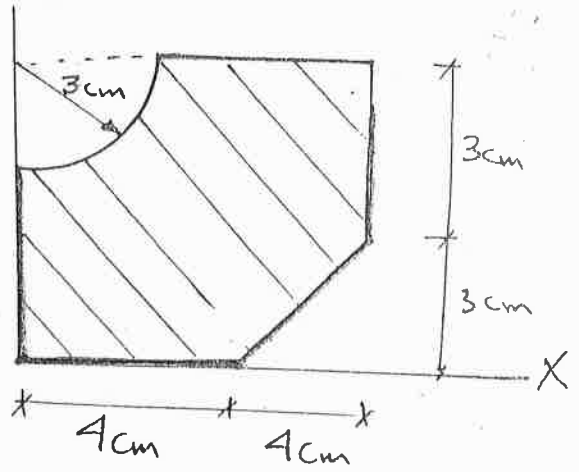

Seg.	$I_{\bar{x}}$	A	d^2	$A d^2$	I_x
(1)		8x6 =48			$\frac{bh^3}{3} = \frac{8(6)^3}{3}$ =576
(2)		$-\frac{1}{2}(4)(3)$ =-6			$-\frac{4(3)^3}{12} = -9$
(3)	$0.055(3)^4$ =4.455	$-\frac{\pi(3)^2}{4}$ =7.068	$\left[6 - \frac{4(3)}{3\pi}\right]^2$ =(4.726) ² or $\left[6 - 0.424(3)\right]^2$ =(4.726) ²	157.86	$-(4.455 + 157.86)$ =-162.315
$\Sigma A = 34.932$				$= 22.335$	$\Sigma = 404.685$

$I_x = 404.685 \text{ cm}^4$

$K_x = \sqrt{\frac{I_x}{A}} = 3.4 \text{ cm}$

=x.s: Determine $I_{\bar{x}}$ and $I_{\bar{y}}$ the centroid
 $\bar{y} = 207 \text{ mm}$

sol.

$$I_{\bar{x}} = \left[\frac{1}{12} (50) (250)^3 + 50 (250) (207 - 125)^2 \right] + \left[\frac{1}{12} (300) (50)^3 + 300 (50) * (275 - 207)^2 \right]$$

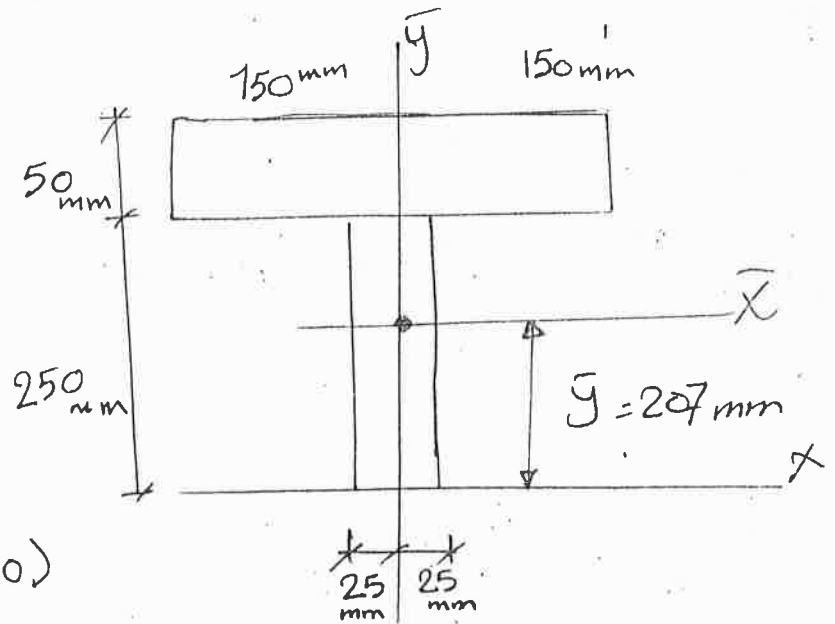

$$I_{\bar{x}} = 222 * 10^6 \text{ mm}^4$$

$$I_{\bar{y}} = \frac{1}{12} (250) (50)^3 + \frac{1}{12} (50) (300)^3 = 115 * 10^6 \text{ mm}^4$$

Ex 4: Find the polar M.O.I about the point O.

sol.

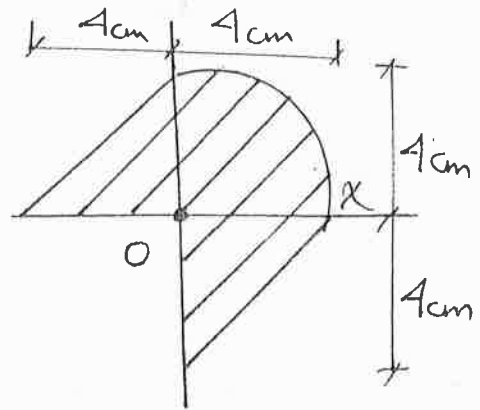
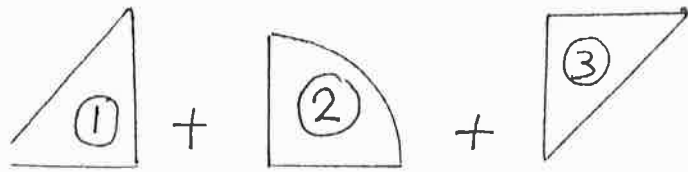

Seq.

1)

2)

3)

$$\underline{I_y}$$

$$21.333$$

$$50.265$$

$$21.333$$

$$92.931$$

$$\underline{I_x}$$

$$\frac{4(4)^3}{12} = 21.333$$

$$\frac{\pi(4)^4}{16} = 50.265$$

$$\frac{4(4)^3}{12} = 21.333$$

$$92.931$$

$$J_o = I_x + I_y = 185.86 \text{ cm}^4$$

H.W: Find J_c with respect to Centroid.

Ans. $J_c = 153.77 \text{ cm}^4$

EX5: Find M.O.I. of the shaded and with respect to the a -axis.

Sol.

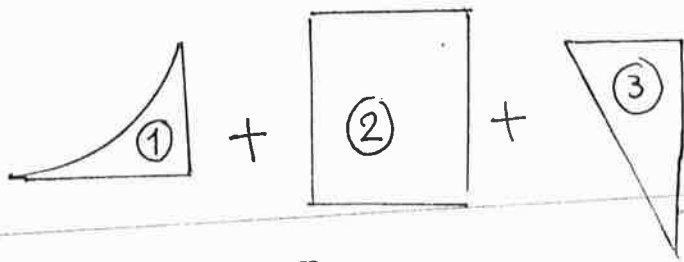
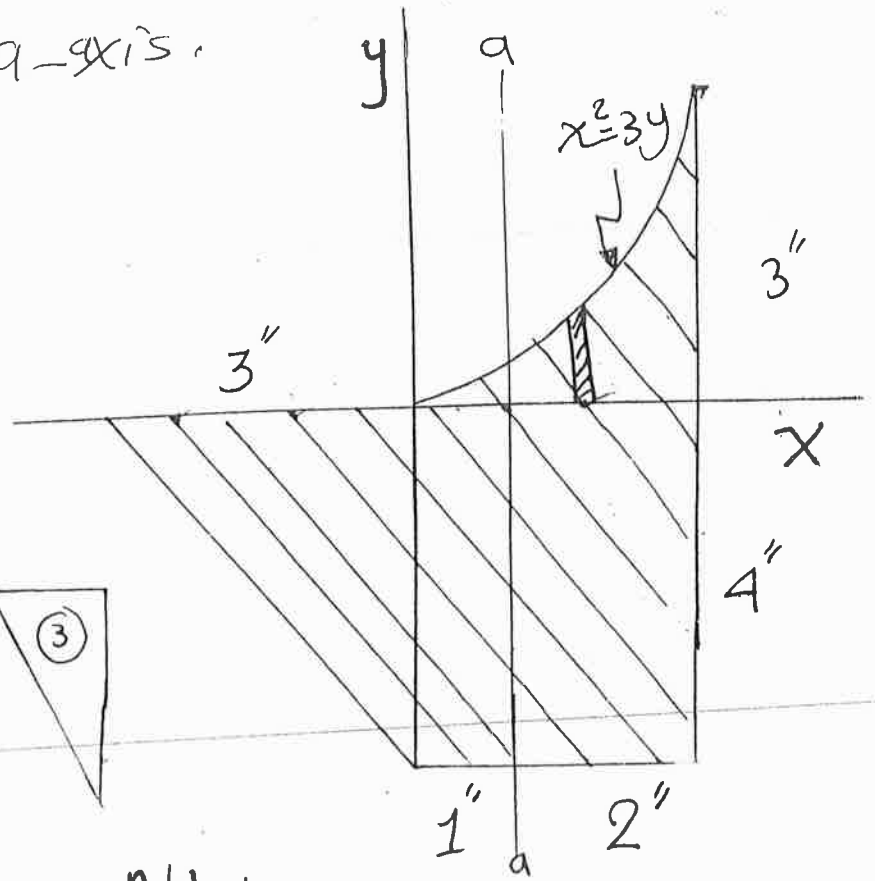

Segment (1)

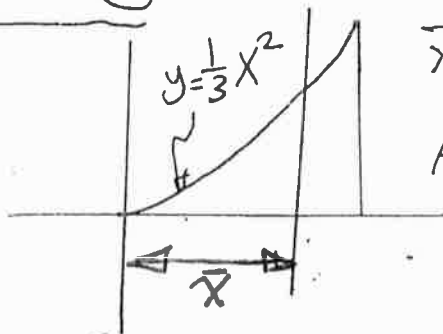

$$\bar{x} = \frac{n+1}{n+2} b$$

$$A = \frac{1}{n+1} bh$$

$$\bar{x} = \frac{2+1}{2+2} (3) = 2.25$$

$$I_y = \int x^2 dA = \int_0^3 x^2 (y dx) = \int_0^3 \frac{1}{3} x^4 dx$$

$$I_y = \frac{1}{15} [x^5]_0^3 = 16.2 \text{ in}^4$$

$$I_{\bar{y}} = I_y - Ad^2 = 16.2 - \frac{1}{3} (3)(3)(2.25)^2$$

$$I_{\bar{y}} = 1.0125 \text{ in}^4$$

$$\Rightarrow I_a = I_{\bar{y}} + Ad^2 = 1.0125 + \frac{1}{3} (3)(3)(1.25)^2$$

$$I_a = 5.7 \text{ in}^4$$

Seg. (2)

$$I_{\bar{y}} = \frac{4(3)^3}{12} = 9$$

$$I_a = I_{\bar{y}} + Ad^2$$

$$= 9 + (4 \times 3) \times (6-5)^2$$

$$I_a = 12 \text{ in}^4$$

Seg. (3)

$$I_{\bar{y}} = \frac{4(3)^3}{36} = 3$$

$$I_a = I_{\bar{y}} + Ad^2$$

$$= 3 + \frac{4(3)}{2} (2)^2$$

$$I_a = 27 \text{ in}^4$$

$$\Rightarrow I_a = 5.7 + 12 + 27$$

$$I_a = 44.7 \text{ in}^4$$

Ex6: For the beam's cross sectional area; Determine the centroid and then compute $I_{\bar{x}}$.

Sol:

$$\bar{x} = \frac{[170 \times 30 \times 115 + 30 \times 200 \times 15 + 70 \times 30 \times 65]}{170 \times 30 + 30 \times 200 + 70 \times 30}$$

$$\bar{x} = 61.59 \text{ mm}$$

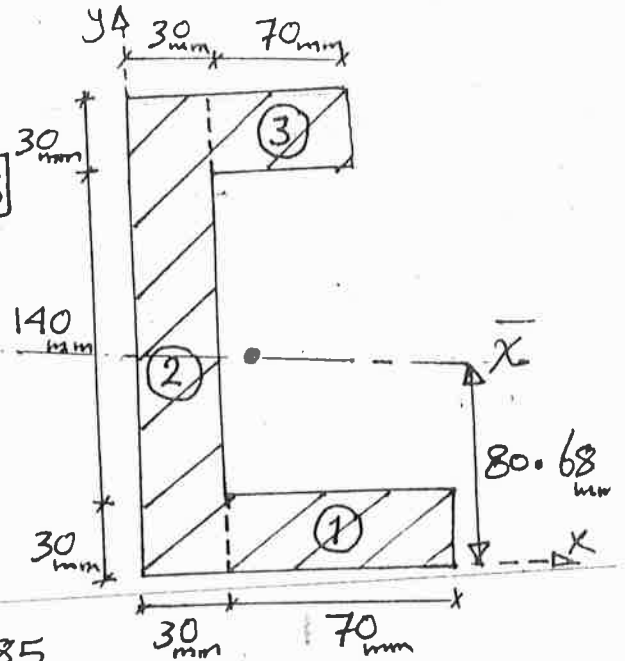

$$\bar{y} = \frac{170 \times 30 \times 15 + 30 \times 200 \times 100 + 70 \times 30 \times 185}{170 \times 30 + 30 \times 200 + 70 \times 30}$$

$$\bar{y} = 80.68 \text{ mm}$$

$$I_{\bar{x}} = \left[\frac{1}{12} (170)(30)^3 + 170 \times 30 \times (80.68 - 15)^2 \right] +$$

$$\left[\frac{1}{12} (30)(200)^3 + 30 \times 200 (100 - 80.68)^2 \right] +$$

$$\left[\frac{1}{12} (70)(30)^3 + 70 \times 30 (185 - 80.68)^2 \right]$$

$$I_{\bar{x}} = 67.63 \times 10^6 \text{ mm}^4$$

Ex. 7: Determine $I_{\bar{x}}$:

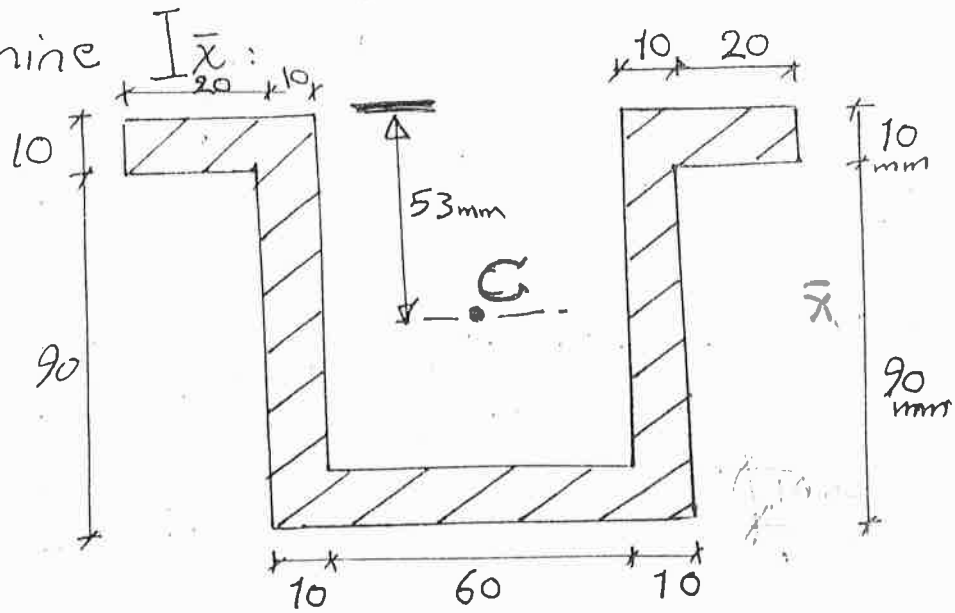
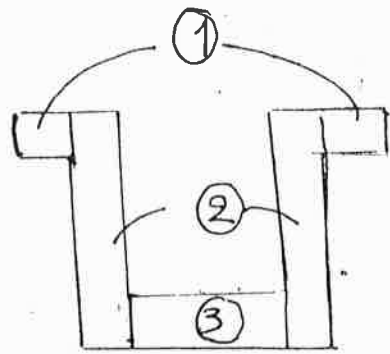

Sol.

<u>Seg.</u>	<u>I_{x_c}</u>	<u>A</u>	<u>d</u>	<u>Ad^2</u>	<u>$I_{\bar{x}}$</u>
①	$\frac{2}{12}(20)(10)^3$	$2(20)(10)$	48	921600	0.9219×10^6
②	$\frac{2}{12}(10)(100)^3$	$2(10)(100)$	3	18000	1.6847×10^6
③	$\frac{1}{12}(60)(10)^3$	60×10	42	1058400	1.0634×10^6

$$I_{\bar{x}} = 3.673 \times 10^6 \text{ mm}^4$$

Ex. 8: Determine the radius of gyration (K_x) for the column cross sectional area.

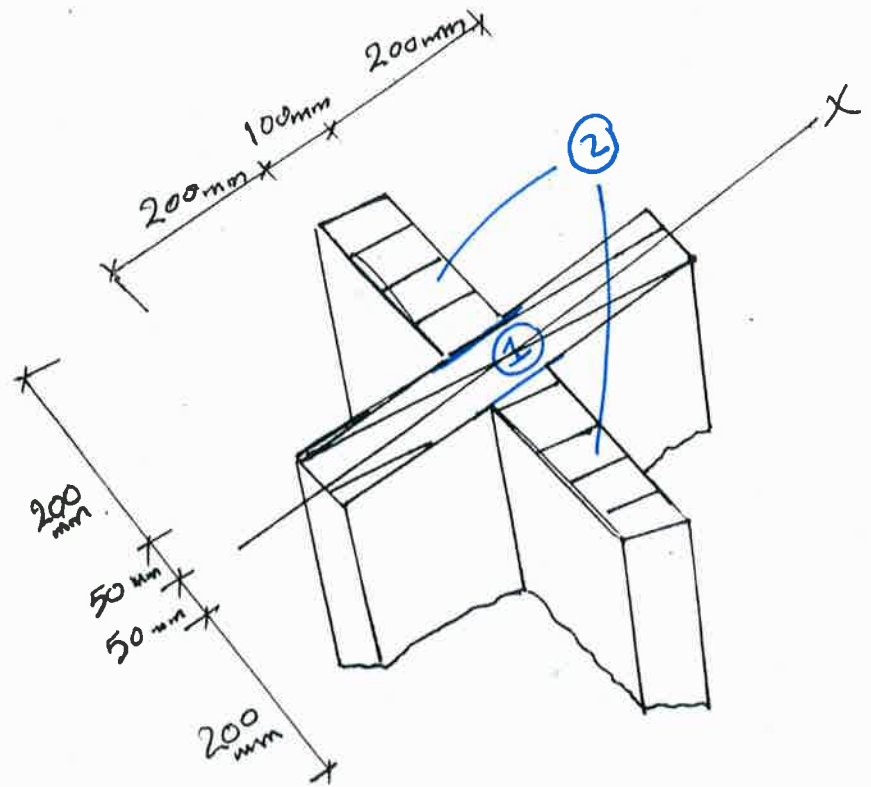

Sol.

$$I_x = \frac{1}{12} (500)(100)^3 + 2 \left[\frac{1}{12} (100)(200)^3 + 100 * 200 * (150)^2 \right]$$

$$I_x = 1.075 * 10^9 \text{ mm}^4$$

$$K_x = \sqrt{\frac{I_x}{A}} = \sqrt{\frac{1.075 * 10^9}{(500)^2 - 4(200)^2}}$$

$$\leftarrow A = 90000 \text{ mm}^2$$

$$K_x = 109.3 \text{ mm}$$

Product of Inertia for an Area:

In some applications of structural design it is necessary to know the orientation of axes that give the maximum and minimum moments of inertia for the area.

The method for determining this needs the product of inertia.

The product of inertia for an area is:

$$I_{xy} = \int xy \, dA$$

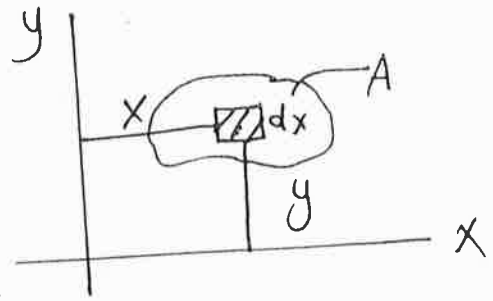

The product of inertia may be positive, negative, or zero depending on the location of the coordinate axes.

The P.O.I. will be zero if either (x) or (y) axis is an axis of symmetry.

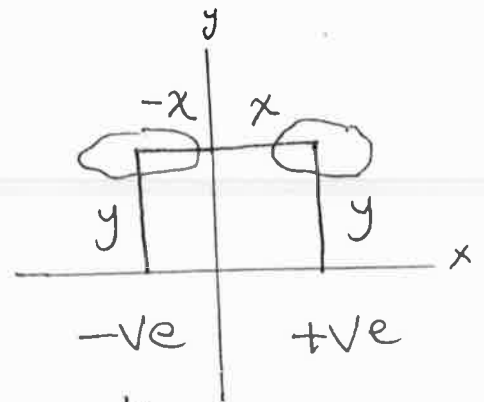

$$I_{xy} = \int xy \, dA + \int -xy \, dA = 0$$

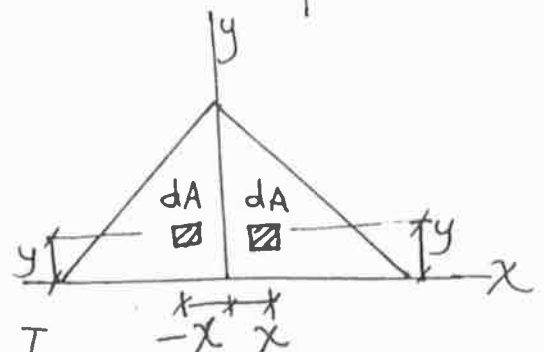

The parallel axis theorem in P.O.I is:

$$I_{xy} = I_{\bar{x}\bar{y}} + A d_x d_y$$

Ex 1: Determine the p.o.I about x & y axes:-

I_{xy} ?

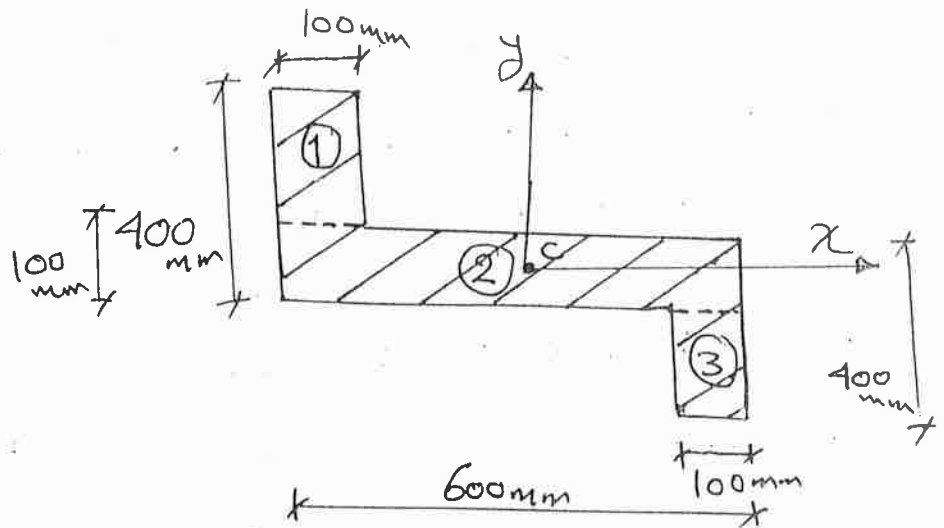

Sol.

seg (1): $I_{xy} = I_{\bar{x}\bar{y}} + A d_x d_y$

$I_{\bar{x}\bar{y}} = 0$
due to symm.

$$= 0 + 300 \times 100 (-250)(200)$$

$$= -1.5 \times 10^9 \text{ mm}^4$$

seg. (2): $I_{xy} = 0 + 0 = 0$

seg. (3): $I_{xy} = 0 + 300 \times 100 (250)(-200)$

$$= -1.5 \times 10^9 \text{ mm}^4$$

The p.o.I. for the total area =

$$-1.5 \times 10^9 + 0 - 1.5 \times 10^9$$

$$= -3 \times 10^9 \text{ mm}^4$$

Ex. 2: Determine the product of inertia for the angle with respect to \bar{x} & \bar{y} axes.

Section

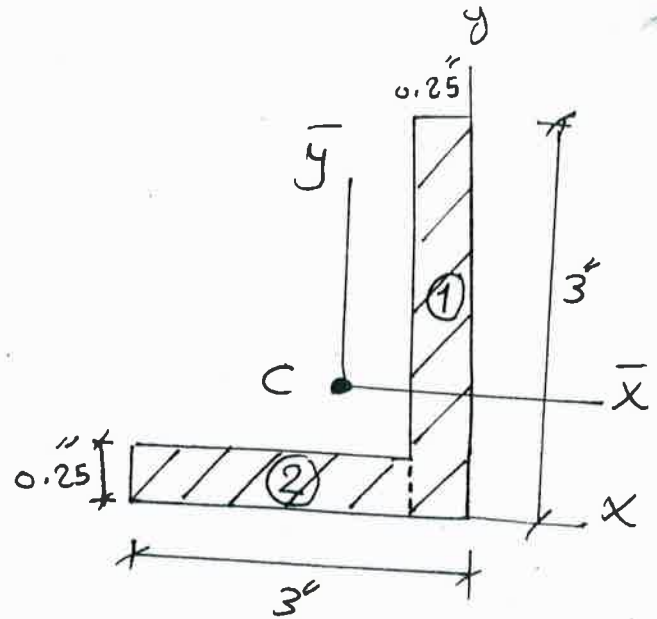

Sol.

$$\bar{x} = \frac{\sum xA}{\sum A} = \frac{(0.25)(3)(-0.125) + (2.75)(0.25)(-1.625)}{0.25 \cdot 3 + 2.75 \cdot 0.25}$$

$$\bar{x} = -0.8424 \text{ in}$$

$$\bar{y} = \frac{\sum yA}{\sum A} = \frac{(0.25)(3)(1.5) + (2.75)(0.25)(0.125)}{0.25 \cdot 3 + 2.75 \cdot 0.25}$$

$$\bar{y} = 0.8424 \text{ in}$$

$$I_{\bar{x}\bar{y}} = (0.25)(3)(0.7174)(0.6576) + (0.25)(2.75)(-0.7826)(-0.7174) + (0.25)(3)(0.8424 - \frac{0.25}{2})(1.5 - 0.8424) + (0.25)(2.75)(-\frac{2.75}{2} + 0.25 - 0.8424)(0.8424 - \frac{0.25}{2})$$

$$I_{\bar{x}\bar{y}} = 0.740 \text{ in}^4$$

Moment of Inertia for an Area About Inclined Axes

In structural design, it is sometimes necessary to calculate the M.O.I. about inclined axes.

The transformation equations are used to do this.

These eqs. are:-

$$u = x \cos \theta + y \sin \theta$$

$$v = y \cos \theta - x \sin \theta$$

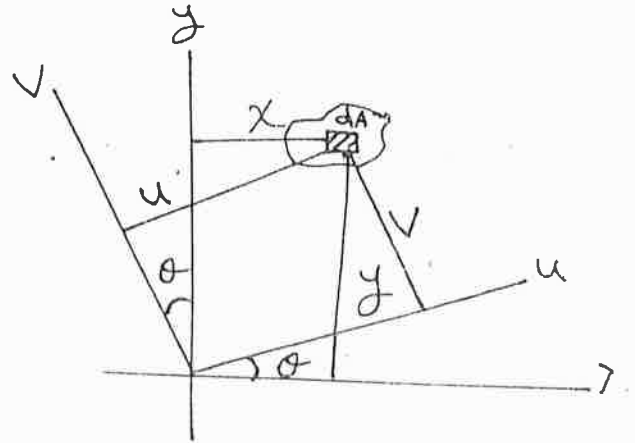

By using these equations, the M.O.I. and P.O.I become:-

$$I_u = \frac{I_x + I_y}{2} + \frac{I_x - I_y}{2} \cos 2\theta - I_{xy} \sin 2\theta$$

$$I_v = \frac{I_x + I_y}{2} - \frac{I_x - I_y}{2} \cos 2\theta + I_{xy} \sin 2\theta$$

$$I_{uv} = \frac{I_x - I_y}{2} \sin 2\theta + I_{xy} \cos 2\theta$$

$$J_o = I_u + I_v = I_x + I_y$$

Principal M.O.I.

The values of I_u , I_v , and I_{uv} depend on the angle of inclination θ of u & v axes.

The axes at which the values of I_u & I_v are maximum & minimum are called principal axes and the corresponding moments of inertia with respect to these axes, are called principal M.O.I.

The angle θ_p defines the orientation of the principal axes for the area.

This angle is determined from:

$$\tan 2\theta_p = \frac{-I_{xy}}{(I_x - I_y)/2}$$

The Max. & Min. M.O.I obtained from:

$$I_{\max.} \quad \min. = \frac{I_x + I_y}{2} \pm \sqrt{\left(\frac{I_x - I_y}{2}\right)^2 + I_{xy}^2}$$

Ex: Determine the principal M.O.I. for the beam cross sectional area with respect to an axis passing through the centroid.

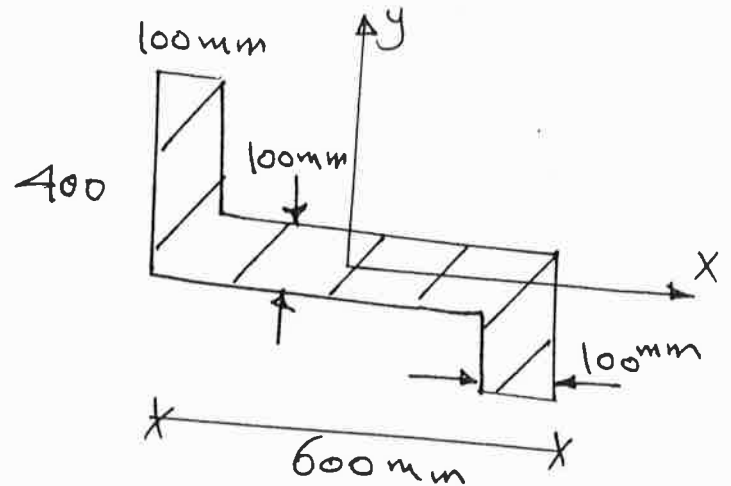

Sol.

$$I_x = 2.9 \times 10^9 \text{ mm}^4, \quad I_y = 5.6 \times 10^9 \text{ mm}^4, \quad I_{xy} = 3 \times 10^9 \text{ mm}^4$$

$$\tan 2\theta_p = \frac{-I_{xy}}{(I_x - I_y)/2} = \frac{3 \times 10^9}{(2.9 \times 10^9 - 5.6 \times 10^9)/2} = -2.22$$

$$2\theta_p = -65.8^\circ$$

$$\theta_p = -32.9^\circ$$

$$90 - 32.9 = 57.1$$

$$I_{\max.} = \frac{I_x + I_y}{2} + \sqrt{\left(\frac{I_x - I_y}{2}\right)^2 + I_{xy}^2}$$

$$I_{\min.} = \frac{I_x + I_y}{2} - \sqrt{\left(\frac{I_x - I_y}{2}\right)^2 + I_{xy}^2}$$

substitute for I_x , I_y and I_{xy}

$$I_{\max.} = 4.25 \times 10^9 + 3.29 \times 10^9$$

$$I_{\min.} = 0.96 \times 10^9 \text{ mm}^4$$

$$I_{\max.} = 7.54 \times 10^9 \text{ mm}^4$$

$$I_{\min.} = 0.96 \times 10^9 \text{ mm}^4$$

about u-axis

about v-axis

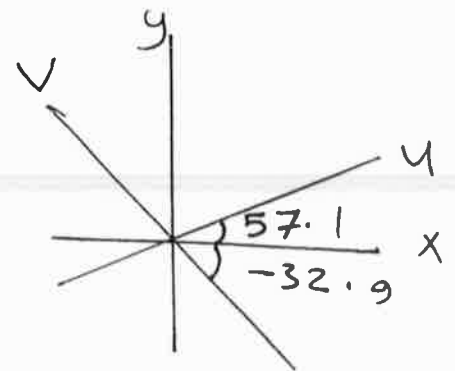

FRICTION

When a body slides or tends to slide on another body, the force that tangent to the contact surface which resists the motion, or the tendency toward motion, of one body relative to the other is defined as friction.

When two bodies are in contact and assumed to be smooth, the reaction of one body on the other is a force normal to the contact surface.

In actual practice, the contact surface is not smooth, and the reaction is resolved into two components, one perpendicular and the other tangent to the contact surface.

The component tangent to the surface is called the frictional force or the friction.

Actually:

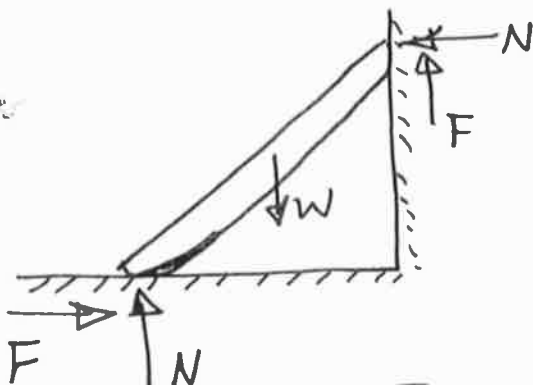

F : frictional force
 N : Normal force

When there is no relative motion between two bodies, the resistance to any tendency toward relative motion is called static friction. When one body moves relative to another body, the resistance force between the bodies is called kinetic friction.

The static frictional force is the minimum force required to maintain equilibrium or prevent relative motion between the bodies.

The kinetic friction varies somewhat with the velocity.

The variation of the frictional force versus the applied load on the body is shown in the Fig. below.

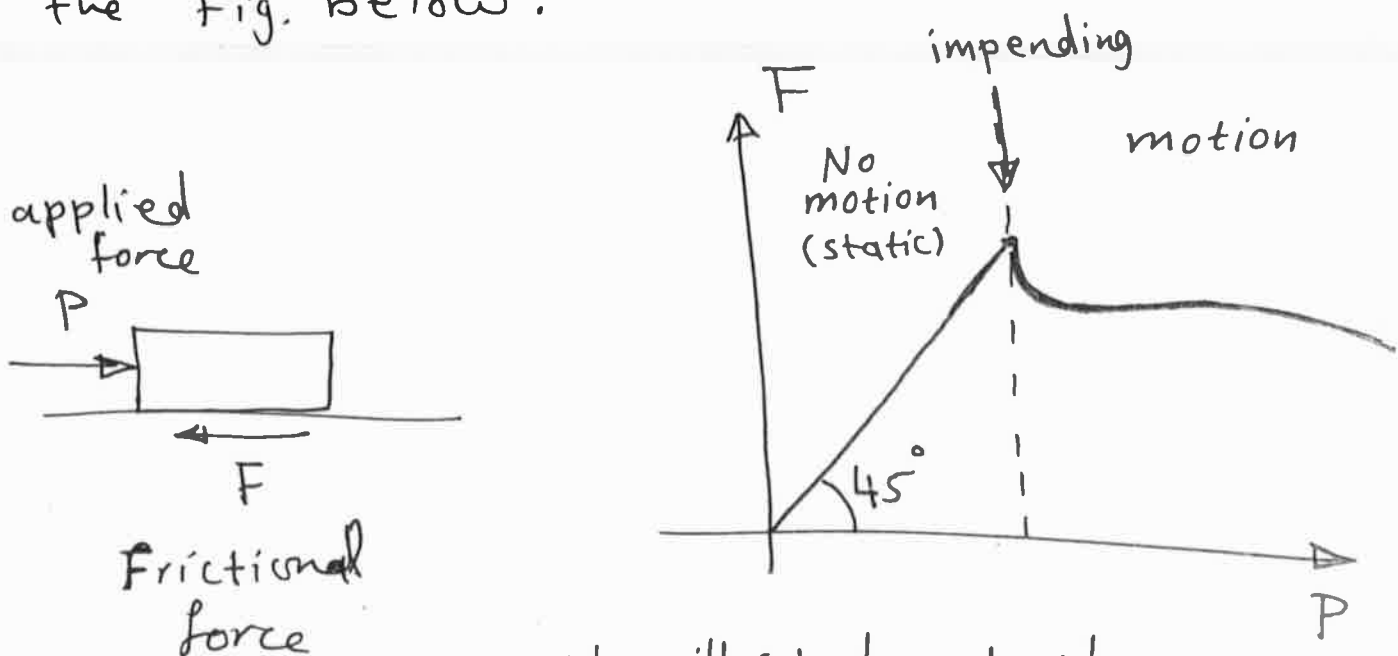

We will study only the static friction.

Coefficient of Friction :

The coefficient of static friction μ is the ratio of the maximum static frictional force F_s to the normal force N .

$$\text{Or } \mu = \frac{(F_s)_{\max}}{N}$$

The coeff. of the static friction is experimentally determined, and depends on the materials from which the contact bodies are made.

The table below shows the values of coeff. of static friction obtained by experiments on dry surfaces.

<u>Contact Materials</u>	<u>Coeff. of static friction</u>
Steel on steel	0.4 - 0.8
Wood on wood	0.3 - 0.7
Wood on metal	0.2 - 0.6
Rubber on concrete	0.6 - 0.8
Rubber on ice	0.05 - 0.2
Metal on ice	0.03 - 0.05

Angle of Friction:

The angle of friction ϕ is the angle which R makes with N .

$$\Rightarrow N = R \cos \phi$$

$$F_s = R \sin \phi$$

$$\mu = \tan \phi = \frac{F_s}{N}$$

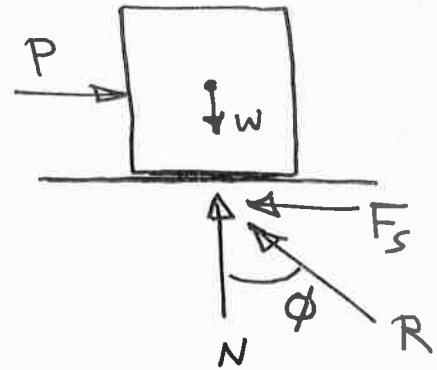

Ex.1: The crate has a mass of 20 kg. Determine if it remains in equilibrium. Use $\mu_s = 0.3$.

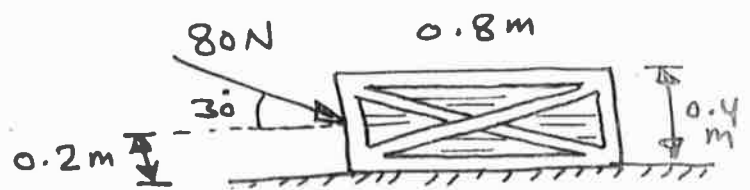

Sol. First draw F.B.D.

$$W = 20 \times 9.81 = 196.2 \text{ N}$$

$$\rightarrow \Sigma F_x = 0$$

$$80 \cos 30 - F = 0$$

$$\Rightarrow F = 69.3 \text{ N}$$

$$\uparrow \Sigma F_y = 0$$

$$-80 \sin 30 + N - 196.2 = 0$$

$$\Rightarrow N = 236 \text{ N}$$

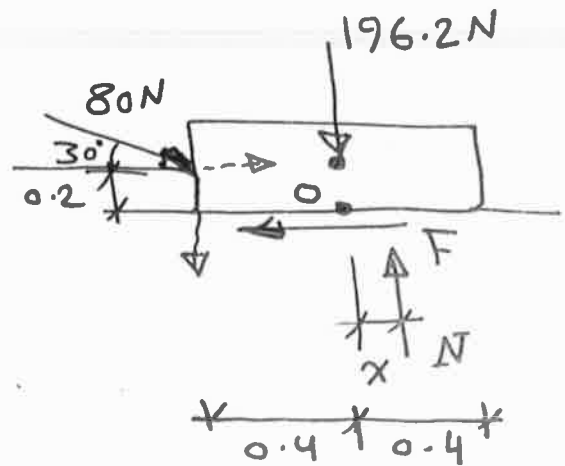

$$\overset{+}{\curvearrowright} \sum M_o = 0$$

$$-80 \sin 30 (0.4) + 80 \cos 30 (0.2) - \overset{236}{N} (x) = 0$$

$$\Rightarrow x = -0.00908 \text{ m}$$

$\Rightarrow N$ located to the left of point o .

\Rightarrow No tipping since $|x| \leq 0.4 \text{ m}$.

$$\begin{aligned} \text{Max. frictional force} = F_{\text{max.}} &= \mu_s N \\ &= 0.3(236) \\ &= 70.8 \text{ N} \end{aligned}$$

$$\text{But } F = 69.3 \text{ N}$$

$\Rightarrow F < F_{\text{max.}} \Rightarrow$ No slipping.

Since there is no tipping or slipping, the crate remains in equilibrium.

Notes

① if $x \leq \frac{b}{2}$
 \Rightarrow no tipping.

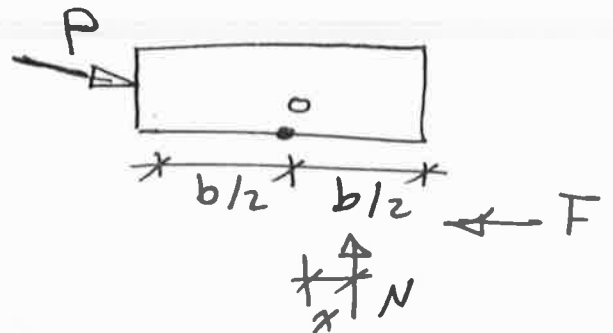

② if $x > \frac{b}{2} \Rightarrow$ tipping.

③ if $F < F_{\text{max.}} \Rightarrow$ no motion (no slipping).

④ if $F = F_{\text{max.}} \Rightarrow$ impending.

Ex.2: A block has a weight of 20 kN. Determine the largest angle θ before the block moves.
Use $\mu_s = 0.55$.

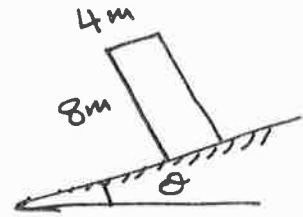

Sol. We can use the inclined axes x & y as a reference axes.

Draw F.B.D.

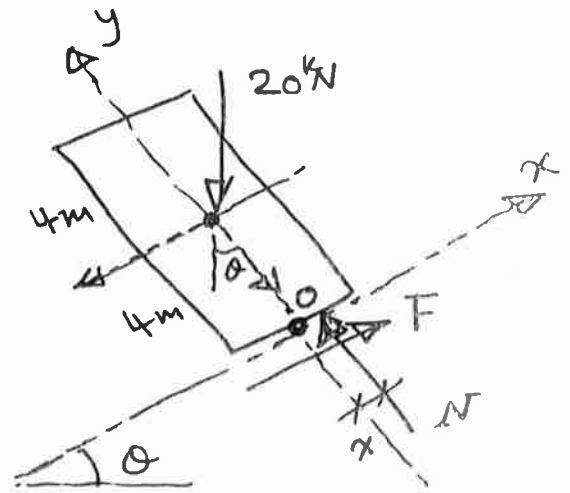

$$\rightarrow \Sigma F_x = 0$$

$$F - 20 \sin \theta = 0 \quad \text{--- (1)}$$

$$\Rightarrow F = 20 \sin \theta$$

$$\nearrow \Sigma F_y = 0$$

$$N - 20 \cos \theta = 0 \quad \text{--- (2)}$$

$$\Rightarrow N = 20 \cos \theta$$

$$\curvearrow \Sigma M_o = 0$$

$$-20 \sin \theta (4) - \underbrace{20 \cos \theta (x)} = 0 \quad \text{--- (3)}$$

At impending motion of block: $F = \mu_s \cdot N$

$$\Rightarrow F = 0.55 N \quad \text{--- (4)}$$

Substitute F (eq.4) into (eq.1) \Rightarrow solve (eq.1) & (eq.2)

\Rightarrow solve (eq.3) \Rightarrow solve (eq.4).

$$\Rightarrow N = 17.5 \text{ kN}, F = 9.64 \text{ kN}, \theta = 28.8^\circ, x = 2.2 \text{ m} = 2.2 \text{ m (left)}$$

Since $2.2 \text{ m} > 2 \text{ m}$, the block will tip before slipping.

To find the max. angle before tipping substitute

$$x = 2 \text{ m in eq. (3)} \Rightarrow \boxed{\theta = 26.56^\circ} \text{ the largest angle before the block moves.}$$

Ex. 3: The beam AB is supported at B by a post BC. If $\mu_B = 0.2$ and $\mu_C = 0.5$, determine the force P needed to pull the post out from under the beam.

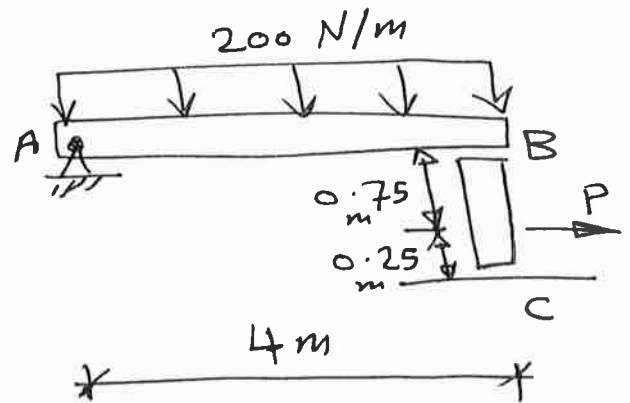
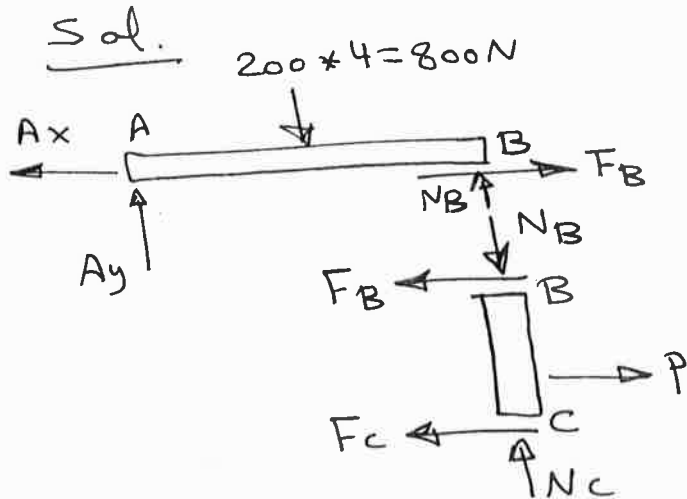

F.B.D. (beam):

$$\sum M_A = 0 \Rightarrow N_B = 400 \text{ N} \uparrow$$

F.B.D. (Post):

$$\sum F_x = 0 \Rightarrow P - F_B - F_c = 0 \quad \text{--- (1)}$$

$$\sum F_y = 0 \Rightarrow N_c = 400 \text{ N} \uparrow$$

$$\sum M_c = 0 \Rightarrow P(0.25) - F_B(1) = 0 \quad \text{--- (2)}$$

If post slips only at B:

$$F_B = \mu_B N_B = 0.2(400) = 80 \text{ N}$$

$$\Rightarrow \text{from eq. (2): } P = 320 \text{ N}$$

$$\text{from eq. (1): } F_c = 240 \text{ N}$$

If post slips only at C:

$$F_c = 0.5 N_c = 200 \text{ N}$$

$$\Rightarrow \text{solve eq. (1) \& (2) } \Rightarrow P = 26.7 \text{ N}, F_B = 66.7 \text{ N}$$

This case occurs first since it requires a smaller value of P. \Rightarrow $P = 26.7 \text{ N}$

page

161

Ex.4: A 35-kg disk rests on an inclined surface for which $\mu_s = 0.2$. Determine the max. vertical force P that may be applied to link AB without causing the disk to slip at C .

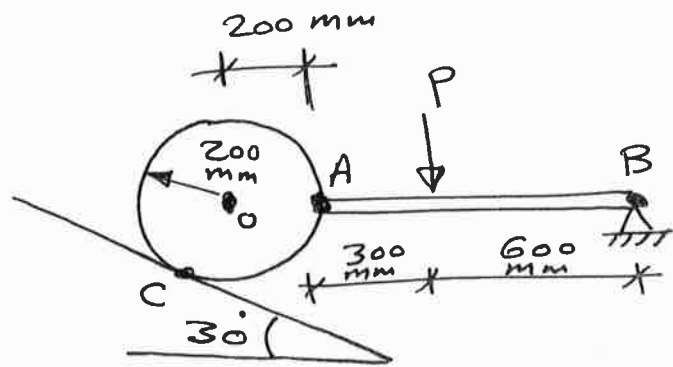

Sol. Draw F.B.D.

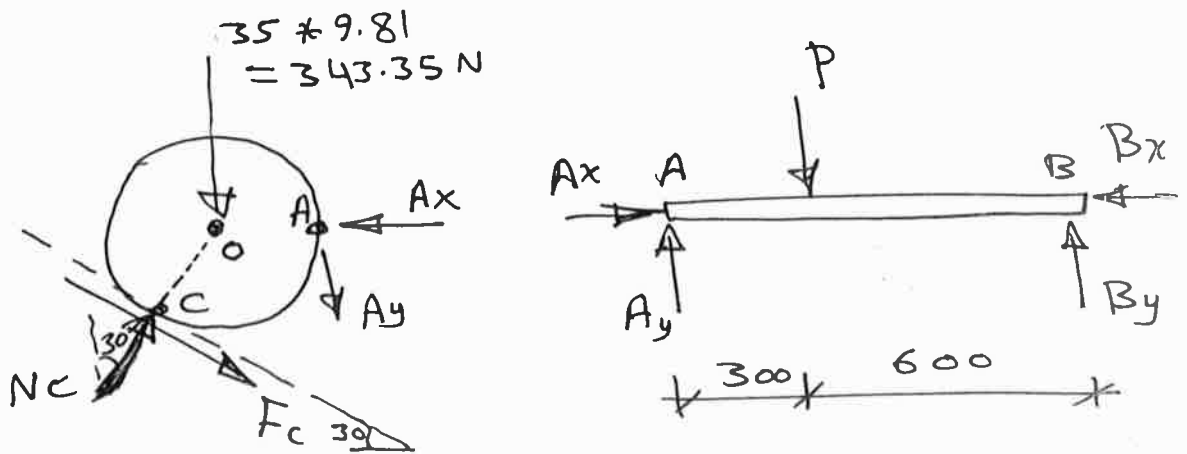

F.B.D. (beam):
 $\sum M_B = 0 \Rightarrow -P(600) + A_y(900) = 0 \Rightarrow A_y = 0.6667P \uparrow$

F.B.D. (disk):
 $\sum F_y = 0 \Rightarrow -343.35 - 0.6667P - F_c \sin 30 + N_c \cos 30 = 0 \quad \text{--- (1)}$
 $\sum M_o = 0 \Rightarrow -F_c(200) + 0.6667P(200) = 0 \quad \text{--- (2)}$

Friction: $F_c = \mu_s \cdot N_c = 0.2 N_c$

solve (1) & (2) \Rightarrow $P = 182 \text{ N}$, $N_c = 606.60 \text{ N}$

Wedges :

A wedge is a simple machine which is often used to transform an applied force into much larger forces, directed approximately at right angles to the applied force. Also wedges can be used to give small displacements or adjustments to heavy loads.

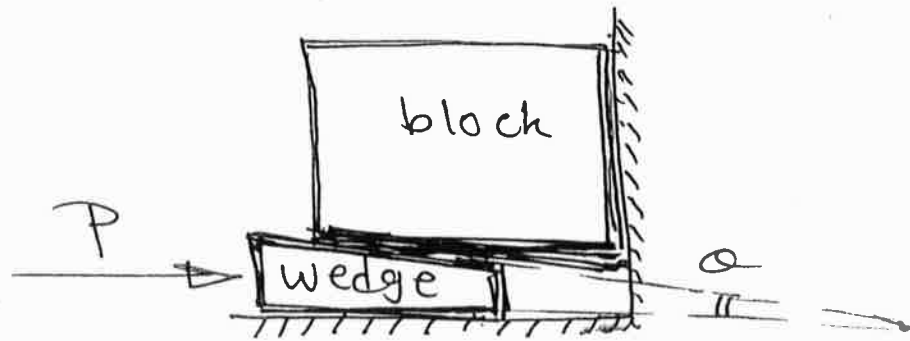

F.B.D.

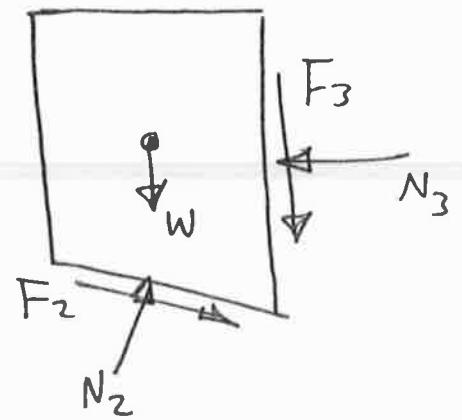
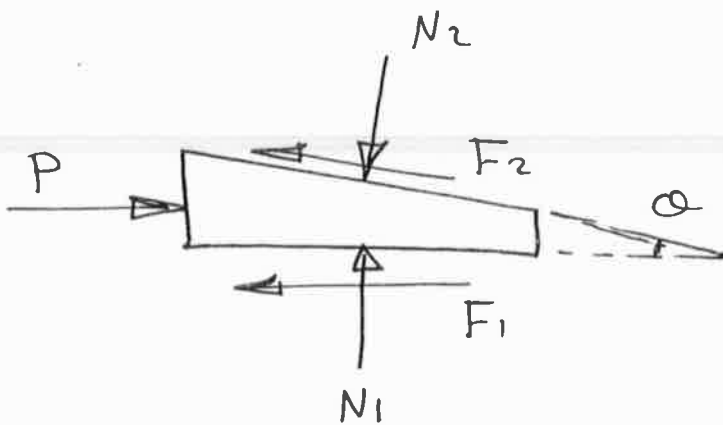

- The weight of wedge is neglected.
- The location of normal forces N is not important since neither block or wedge will tip.

Ex.1: The beam is adjusted to the horizontal position by using a wedge located at its right support. If $\mu_s = 0.25$, determine the horizontal force P required to push the wedge forward. Neglect the weight and size of the wedge and the thickness of the beam.

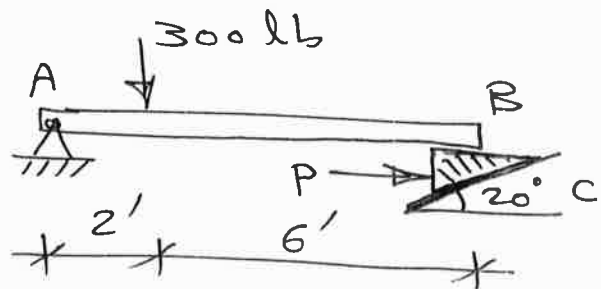

Sol. F.B.D.:

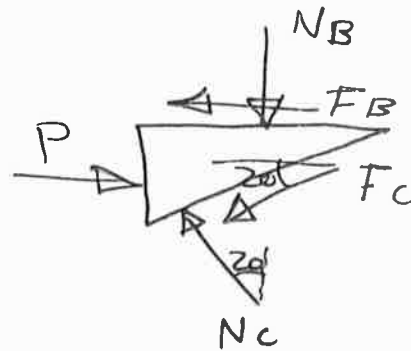

$$F_B = 0.25 N_B$$

$$F_C = 0.25 N_C$$

F.B.D. (beam): $\sum M_A = 0 \Rightarrow -N_B(8) + 300(2) = 0$

$$\Rightarrow N_B = 75 \text{ lb } \uparrow$$

$$\Rightarrow F_B = 0.25 * 75 = 18.75 \text{ lb}$$

F.B.D. (wedge):

$$\uparrow \sum F_y = 0 \Rightarrow N_C \cos 20 - 0.25 N_C \sin 20 - 75 = 0$$

$$\Rightarrow N_C = 87.8 \text{ lb}$$

$$\Rightarrow F_C = 0.25 * 87.8 = 21.95 \text{ lb}$$

$\rightarrow \sum F_x = 0$:

$$P - 18.75 - 21.95 * \cos 20 - 87.8 * \sin 20 = 0$$

$$\Rightarrow \boxed{P = 69.4 \text{ lb}}$$

Ex. 2: Determine the horizontal force P which must be applied to the wedge in order to remove it from under the beam. Use $\mu_A = 0.25$, $\mu_B = 0.35$.

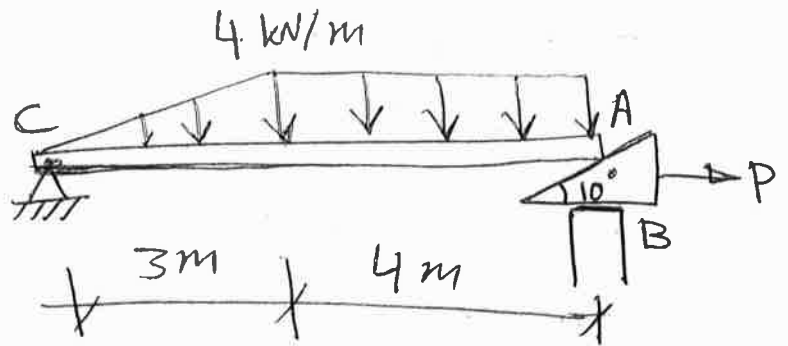

Sol. Draw F.B.D.

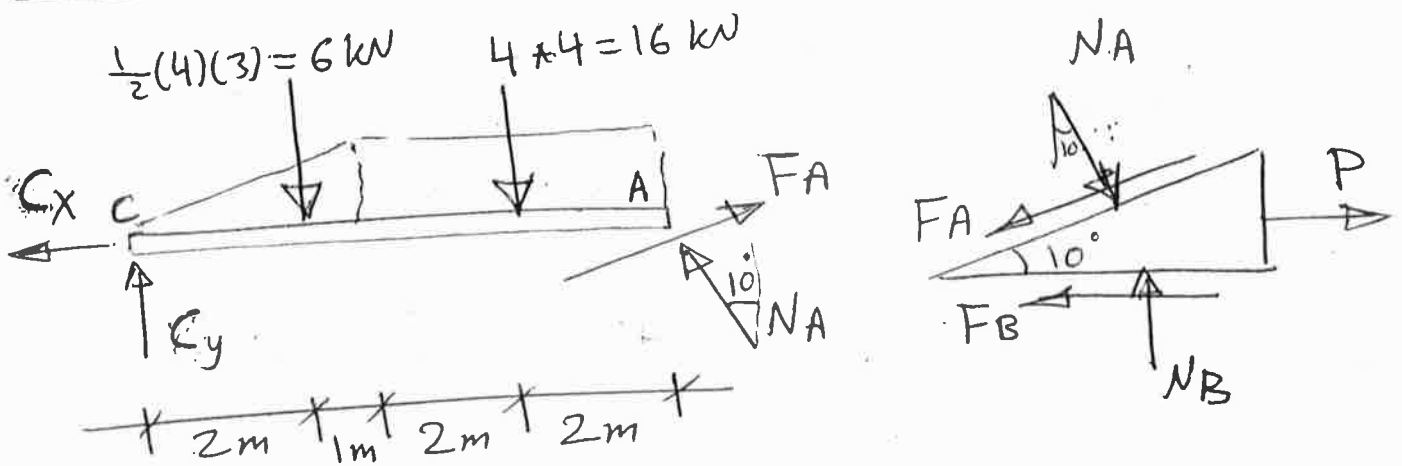

F.B.D. (beam):

$$\sum M_C = 0 : -N_A \cdot \cos 10^\circ (7) - \underbrace{F_A \sin 10^\circ}_{0.25 N_A \cdot \sin 10^\circ} (7) + 6(2) + 16(5) = 0$$

$$\Rightarrow N_A = 12.78 \text{ kN}$$

$$\Rightarrow F_A = 0.25(12.78) = 3.195 \text{ kN}$$

F.B.D. (wedge):

$$+\uparrow \sum F_y = 0 : N_B - 12.78 * \cos 10^\circ - 3.195 * \sin 10^\circ = 0$$

$$\Rightarrow N_B = 13.14 \text{ kN}$$

$$\Rightarrow F_B = 0.35(13.14) = 4.6 \text{ kN}$$

$$+\rightarrow \sum F_x = 0 : P + 12.78 * \sin 10^\circ - 3.195 * \cos 10^\circ - 4.6 = 0$$

$$\Rightarrow \boxed{P = 5.53 \text{ kN}}$$

I B. Tech II Semester Supplementary Examinations, Nov/Dec - 2019
ENGINEERING MECHANICS
 (Com. to CSE, IT, AGE)

Time: 3 hours

Max. Marks: 70

- Note: 1. Question paper consists of two parts (**Part-A** and **Part-B**)
 2. Answering the question in **Part-A** is Compulsory
 3. Answer any **FOUR** Questions from **Part-B**

PART -A

1. a) Define couple. (2M)
- b) Write the equations of equilibrium for coplanar concurrent force system. (2M)
- c) What is the distance of centroid of right angled triangle of base 'b' and height 'h', from its base? (2M)
- d) Define the term "product of inertia". (2M)
- e) Illustrate curvilinear motion with an example. (2M)
- f) Write work-energy equation. (2M)
- g) Write kinetic equation of motion for a body rotating with angular acceleration ' α '. (2M)

PART -B

2. a) Define the following. (6M)
 - (i) Law of transmissibility
 - (ii) Parallelogram law of forces
- b) Figure-1 shows the coefficient of static friction is 0.25. Compute the value of the horizontal force 'P' necessary to (8M)
 - (i) Just start the block up the incline.
 - (ii) Just prevent motion down the incline.
 - (iii) If $P=400\text{N}$, what is the amount and direction of the friction force?

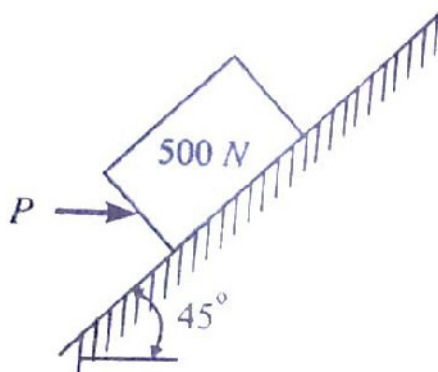

Figure-1

3. a) Determine the axial forces induced in the members of a truss as shown in figure-2 (10M)

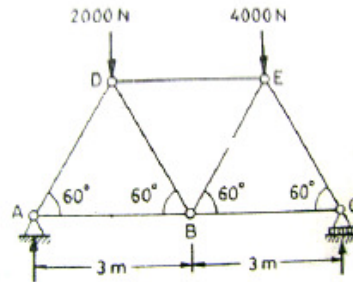

Figure-2

- b) Explain the graphical method for finding the resultant of coplanar concurrent force system. (4M)
4. a) Determine the centroid of a rectangle having base b and height h . (6M)
- b) Locate the centroid of an I-section about X-X axis as shown in the figure-3. (8M)

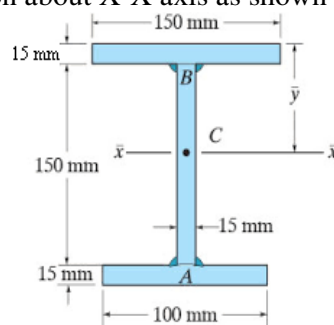

Figure-3

5. a) State and derive transfer theorem for areas. (6M)
- b) Find area moment of inertia of L section shown in Figure-4 about X axis. (8M)

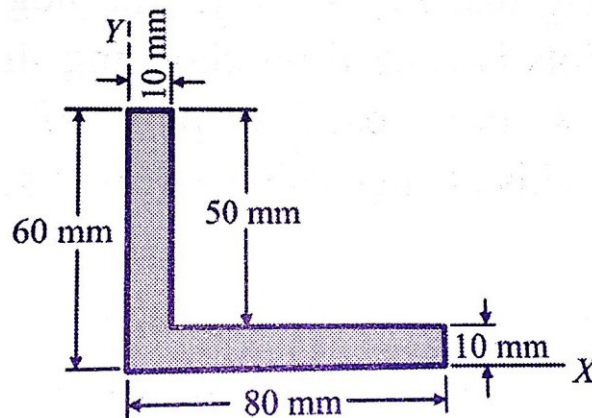

Figure-4

6. a) A stone is dropped into a well while splash is heard after 2.5 seconds. Then determine depth of water surface assuming the velocity of sound as 330 m/s. (7M)
- b) A motorist takes 10 seconds to cover a distance of 20m and 15 seconds to cover a distance of 40m. Find the uniform acceleration of the car and the velocity at the end of 15 seconds. (7M)
7. Three blocks A , B and C are connected as shown in the Figure-5. Find acceleration of the masses and the tension T_1 and T_2 in the strings. Given $\mu_1=0.2$ and $\mu_2=0.25$. (14M)

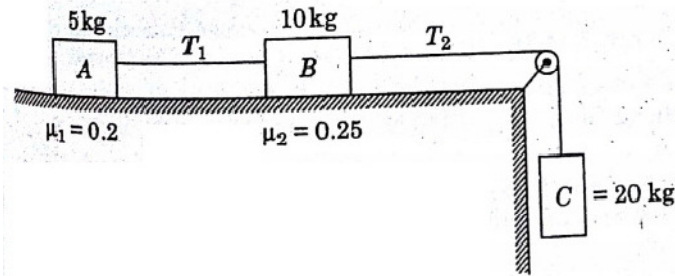

Figure-5

I B. Tech II Semester Supplementary Examinations, December - 2020
ENGINEERING MECHANICS
 (Com. to CSE, IT, Agri E)

Time: 3 hours

Max. Marks: 70

- Note: 1. Question paper consists of two parts (**Part-A** and **Part-B**)
 2. Answering the question in **Part-A** is Compulsory
 3. Answer any **FOUR** Questions from **Part-B**

PART -A

1. a) Define angle of repose. (2M)
- b) State law of Polygon of forces. (2M)
- c) Differentiate between centroid and center of gravity (2M)
- d) Explain the term “polar moment of inertia” (2M)
- e) Illustrate rectilinear motion with examples. (2M)
- f) Write impulse momentum equation. (2M)
- g) State any two columb’s laws of friction. (2M)

PART -B

2. a) A roller of radius 40 cm of weight 3000 N is to be pulled over a rectangular block of height 20 cm as shown in Figure-1. By a force P applied horizontally at the centre of roller. What would be the magnitude of this force? Also determine the least force and its line of action at the centre of the roller for turning the roller over the rectangular block. (10M)

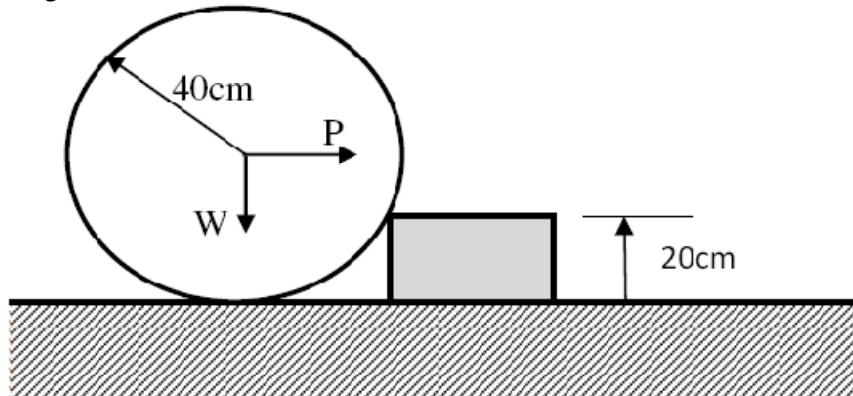

Figure-1

- b) Explain the concept of cone of friction. (4M)
3. a) State and prove lami’s theorem. (6M)

- b) Determine the reactions at supports A and B for the loaded beam as shown in Figure-2 (8M)

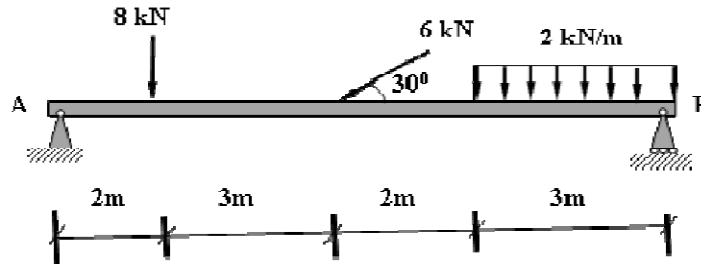

Figure-2

4. a) Determine the coordinates of centroid C of the shaded area as shown in Figure-3 (8M)

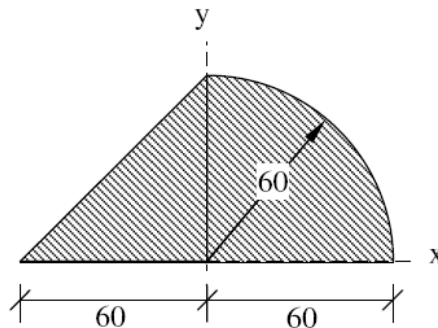

Figure-3

- b) State the theorem of perpendicular axis. How will you prove this theorem? (6M)
5. a) Calculate the moment of inertia of the shaded area in Figure-4 with respect to a centroidal axis parallel to the X axis. (8M)

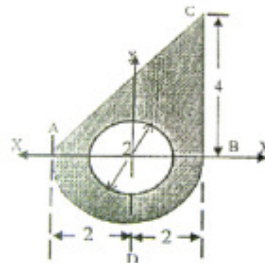

Figure-4

- b) Derive the mass moment of inertia of the rectangular plate about a line passing through the base. (6M)
6. The position of the particle which moves along a straight line is defined by $x = 2t^3 - t^2 - 2t + 4$ where x in m, t is in sec. Determine the following: (14M)
- The time at which the velocity will be zero
 - The position and distance travelled by the particle at that time.
 - Acceleration of the particle at that time.
 - The distance travelled by the particle from $t = 3$ sec and $t = 5$ sec.

7. The $200\text{N} (\cong 20\text{kg})$ crate (figure-5) has a velocity of $V_A = 4\text{m/s}$ when it is at A. (14M)
Determine Its velocity after it slides $S = 2\text{m}$ down the plane. The coefficient of Kinetic friction between the crate and the plane is $\mu_k = 0.2$ (Apply work and energy principle).

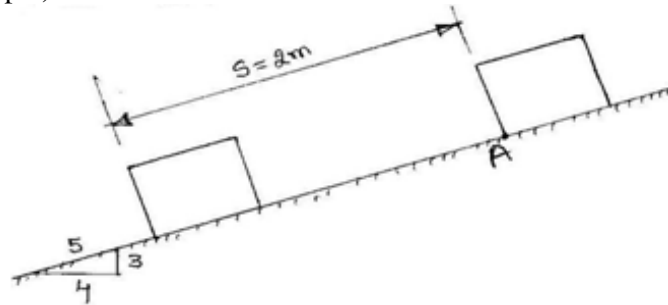

Figure-5

I B. Tech II Semester Regular/Supplementary Examinations, April/May - 2019
ENGINEERING MECHANICS
 (Com. to CSE, IT, AGE)

Time: 3 hours

Max. Marks: 70

- Note: 1. Question Paper consists of two parts (**Part-A** and **Part-B**)
 2. Answering the question in **Part-A** is Compulsory
 3. Answer any **FOUR** Questions from **Part-B**

PART -A

1. a) Define limiting friction and impending motion. (2M)
- b) What are the steps followed while drawing free body diagrams? (2M)
- c) What is the Centroid of a Quarter circle of radius 2 m? (2M)
- d) State perpendicular axis theorem. (2M)
- e) Distinguish between rectilinear motion and curvilinear motion. (2M)
- f) A man weighing 50 kg carries a load of 10 kg to the top of the building in 8 minutes. The work done by the man is 60 kJ. If he carries the same load in 4 minutes, how much work would he do? (2M)
- g) Explain the principle of impulse-momentum. (2M)

PART -B

2. a) Find the resultant of the force acting on a particle P shown in figure. (5M)

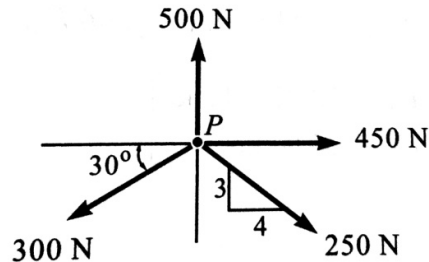

- b) A cylinder of radius 10cm and weight 20N, resting on an inclined plane, has a flexible string wrapped around it. The string does not slip over the cylinder, and is pulled by weight W to support the cylinder as shown in figure. If there is impending slippage, what is the coefficient of static friction between the cylinder and the incline? (9M)

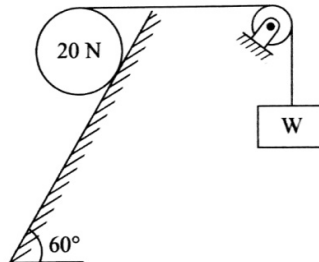

3. a) A 20 kg homogeneous smooth sphere rests on two inclined planes as shown in figure. Determine the contact forces at A and B. (6M)

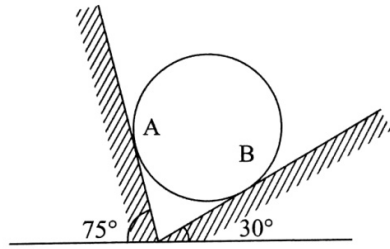

- b) Find the forces in members BD, CD and CE of the truss as shown in figure (the loads are indicated in newtons). (8M)

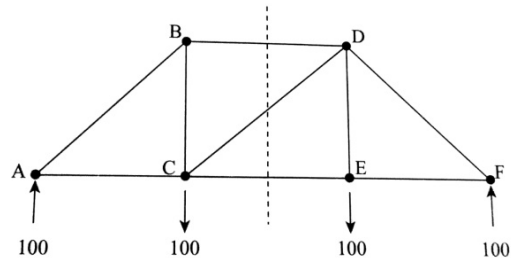

4. a) Locate the centroid of a circular sector of radius r and included angle 2α , selecting the symmetrical radial line as the x -axis. (6M)

- b) A thin homogeneous wire is bent into a triangular shape ABC such that $AB = 240\text{mm}$, $BC = 260\text{mm}$ and $AC = 100\text{mm}$. locate the Center of Gravity of the wire with respect to coordinate axes. Angle at A is right angle. (8M)

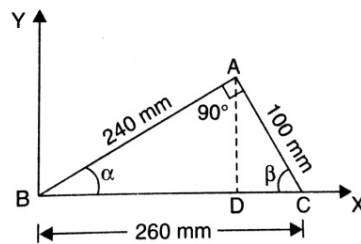

5. a) Determine the product of inertia with respect to the x_0 and y_0 axes passing through the centroid. (7M)

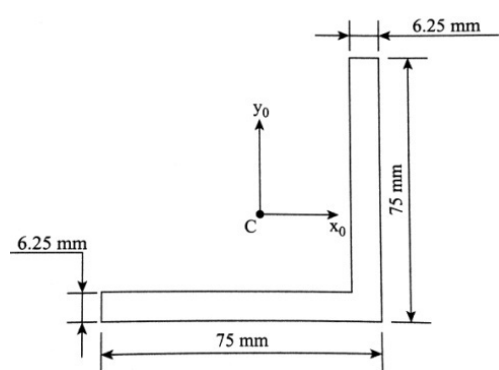

- b) Derive the expression for the moment of inertia of a homogeneous right circular cone of mass m , base radius r and altitude h with respect to its geometric axis. (7M)

6. a) The speed of a truck moving at a constant speed of 30 m/s is reduced to 20 m/s in a distance of 200 m. Determine i) the acceleration assuming to be constant, and ii) the time taken to a stop with the acceleration calculated in part (i).

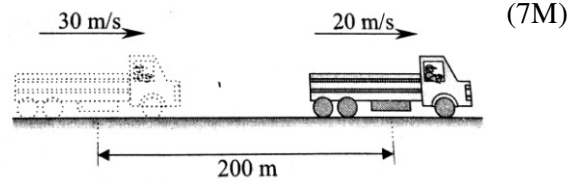

- b) An elevator weighing 6 tons together with the passengers descends with a speed of 4m/s. If the tension in the cable must not exceed 50kN, what is the shortest distance in which the elevator can be stopped? (7M)

7. A solid cylinder of weight 673kg and radius 37cm is pushed with a constant force $F=777\text{N}$, so that it rolls without slip on a rough inclined track having $\mu=0.31$ as shown in figure. To move starting from rest, how much distance will the cylinder take to attain a velocity of 7.7m/s? Take $\alpha=27^\circ$.

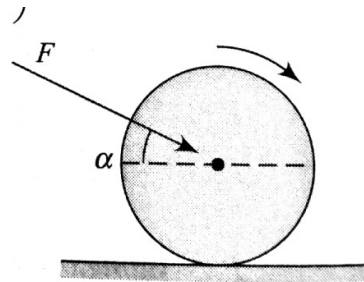

I B. Tech II Semester Regular/Supplementary Examinations, April/May - 2019
ENGINEERING MECHANICS
 (Com. to CSE, IT, AGE)

Time: 3 hours

Max. Marks: 70

- Note: 1. Question Paper consists of two parts (**Part-A** and **Part-B**)
 2. Answering the question in **Part-A** is Compulsory
 3. Answer any **FOUR** Questions from **Part-B**

PART -A

1. a) Define coefficient of friction and Cone of friction. (2M)
- b) Discuss the triangle law to determine the resultant of concurrent forces. (2M)
- c) Differentiate between Centroid and Center of gravity. (2M)
- d) Explain why moment of inertia is always positive while product of inertia can be positive or negative. (2M)
- e) Mention the equation of motion for rolling bodies. (2M)
- f) Under what situation, is it better to apply the principle of impulse-momentum rather than the principle of work-energy? (2M)
- g) State D'Alembert's principle. (2M)

PART -B

2. a) Replace the system of forces and couple shown in figure by a single force couple system at A. (7M)

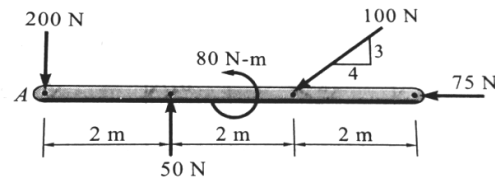

- b) In figure, determine the horizontal force P applied to the lower block to just pull it to the right. The coefficient of friction between the blocks is 0.2 and that between the lower block and the plane is 0.25. Assume the pulley to be frictionless. (7M)

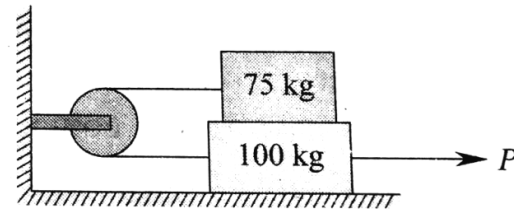

3. a) Block P of mass 5kg and block Q of mass m kg, suspended through a cord, are in the equilibrium position as shown in figure. Determine the mass m. (7M)

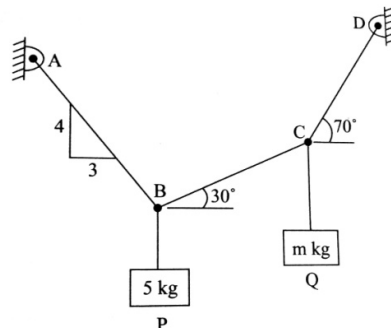

- b) A truss is loaded as shown in figure. Find the forces in members AB, BD and BC.

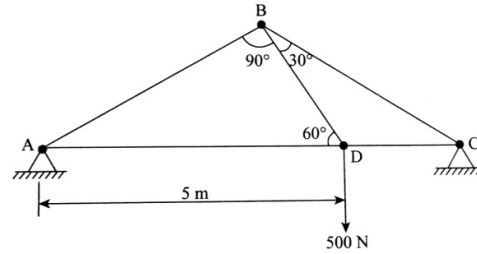

(7M)

4. a) Determine the distance of the centroid from the base of a triangle of altitude h .

(7M)

- b) A wire has been bent into the shape as shown in figure. Determine the position of the centroid of the wire.

(7M)

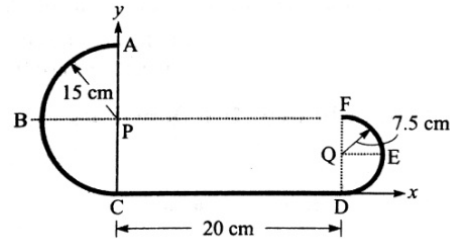

5. a) Calculate the polar moment of inertia of the area shown in figure about point O.

(7M)

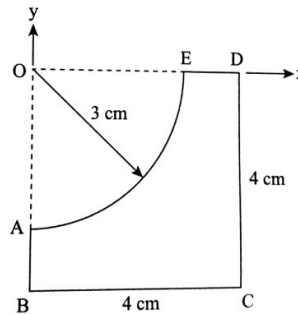

- b) Find the mass moment of inertia of a hollow cylinder about its axis. The mass of the cylinder is 5kg, inner radius 10cm, outer radius 15cm and height 20cm.

(7M)

6. a) A stone is dropped into a well and the splash is heard after 3s. If the speed of sound in air is 340m/s, determine the depth of the well.

(6M)

- b) A solid cylinder weighing 1300N is acted upon by a force P horizontally as shown in figure. Determine the maximum value of P for which there will be rolling without slipping (given $\mu=0.2$).

(8M)

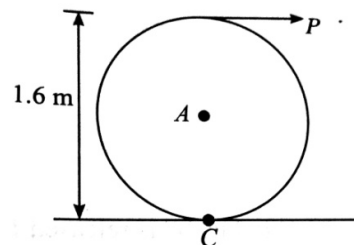

7. A road roller has a total mass of 12,000kg. The front roller has a mass of 2000kg, a radius of gyration of 0.4m and a diameter of 1.2m. The rear axle together with its wheels has a mass of 2500kg, a radius of gyration of 0.6m and a diameter of 1.5m. Calculate the kinetic energy of rotation of the wheels and axle at a speed of 9km/h and total kinetic energy of the road roller.

(14M)

I B. Tech II Semester Regular/Supplementary Examinations, April/May - 2019
ENGINEERING MECHANICS
 (Com. to CSE, IT, AGE)

Time: 3 hours

Max. Marks: 70

- Note: 1. Question Paper consists of two parts (**Part-A** and **Part-B**)
 2. Answering the question in **Part-A** is Compulsory
 3. Answer any **FOUR** Questions from **Part-B**

PART -A

1. a) Explain how to resolve a force in space to determine its components. (2M)
- b) State Lami's theorem. (2M)
- c) State Pappus theorem to find out the surface area and volume of a body. (2M)
- d) Differentiate between polar moment of inertia and product of inertia. (2M)
- e) Define curvilinear motion with suitable examples. (2M)
- f) Show that energy of a freely falling body is constant. (2M)
- g) Explain transfer formula for product of inertia. (2M)

PART -B

2. a) The resultant of two forces acting at a point is 75.71kN, where one force is double that of the other and if the direction of one is reversed, the resultant becomes 57.17kN. Find the magnitudes of two forces and the angle between them. (6M)

- b) Two blocks W_1 and W_2 resting on two inclined planes are connected by a horizontal bar AB as shown in figure. If W_1 equals 1000N, determine the maximum value of W_2 for which the equilibrium can exist. The angle of limiting friction is 20° at all rubbing faces. (8M)

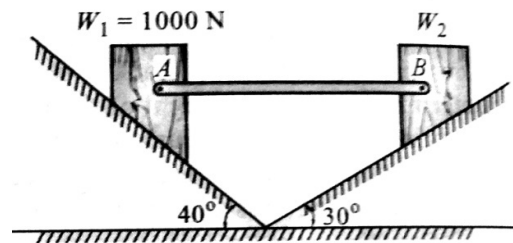

3. a) Three concurrent forces are acting on a body which is in equilibrium, then the resultant of the two forces should be equal and opposite to the third force. Prove this statement. (6M)

- b) Find the forces in members EC, DC and DH of the truss shown in figure. (8M)

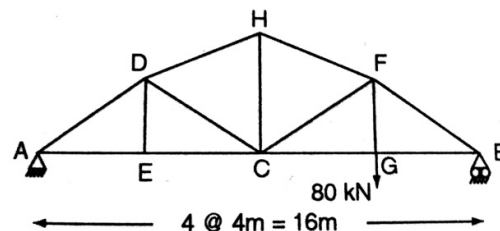

4. a) Locate the centroid of the area bounded by the two coordinate axes and a circle of radius a with its centre at $(0,a)$. (6M)

- b) Find the centre of gravity of the L-section shown in figure

(8M)

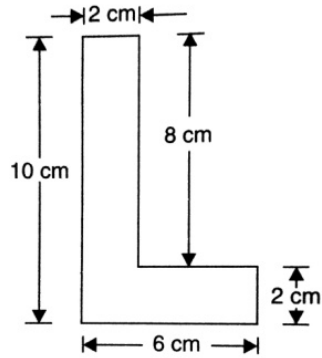

5. a) Determine the product of inertia of a quarter-circular area about its centroidal axes which are parallel to its edges.

(7M)

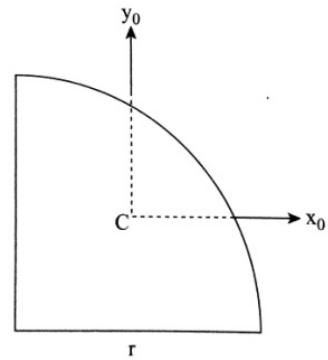

- b) Derive the mass moment of inertia of a rectangular plate about a line passing through the base.

(7M)

6. a) A car covers 100m in 10 seconds, while accelerating uniformly at a rate of 1m/s^2 . Determine i) initial and final velocities of the car, ii) distance travelled before coming to this point assuming it started from rest, and iii) its velocity after the next 10 seconds.

(7M)

- b) A ball is thrown vertically upwards from the ground with an initial velocity of 20m/s. Determine i) the maximum height reached by the ball, ii) the time taken to reach the maximum height, and iii) the total time of flight.

(7M)

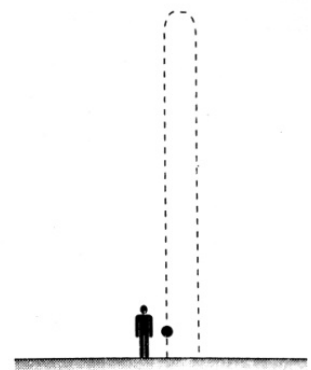

7. Two blocks A and B are connected with an inextensible but flexible string, as shown in figure. Let the system be released from rest. Determine the velocity of the block A after it has moved a distance of 0.7m. Assume that the coefficient of friction between block A and the plane is 0.31. The masses of the blocks are $m_A=95\text{kg}$ and $m_B=143\text{kg}$.

(14M)

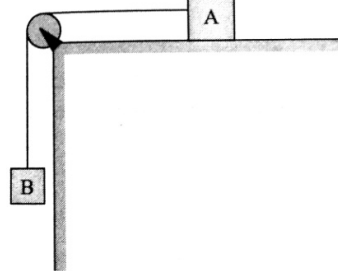

I B. Tech II Semester Regular/Supplementary Examinations, April/May - 2019
ENGINEERING MECHANICS
 (Com. to CSE, IT, AGE)

Time: 3 hours

Max. Marks: 70

- Note: 1. Question Paper consists of two parts (**Part-A** and **Part-B**)
 2. Answering the question in **Part-A** is Compulsory
 3. Answer any **FOUR** Questions from **Part-B**

PART -A

1. a) State Coulomb's law of dry friction. (2M)
- b) State the conditions of equilibrium for coplanar concurrent forces. (2M)
- c) What is the center of gravity of a cuboid with dimensions $(l,b,h) = (30, 40, 90)$ cm? (2M)
- d) Explain the term radius of gyration. What is its application? (2M)
- e) State the equations of equilibrium of a rigid body experiencing a planar motion. (2M)
- f) The work done upon a body by a system of forces causing uniform velocity is zero. Discuss. (2M)
- g) Draw the free body diagram of a block on a smooth inclined plane, is restricted from moving downwards by a string attached to it. (2M)

PART -B

2. a) A 100kg box is shifted by two persons, one pulling it exerting a force of 200N inclined at 20° to the horizontal and another pushing it from behind by exerting a force of 150N inclined at 10° to the horizontal. Determine the resultant force acting on the box. Refer figure. (6M)

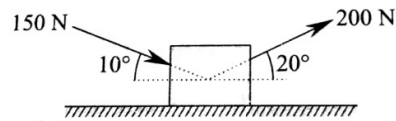

- b) Two blocks A and B are placed on inclined planes as shown in figure. The block A weighs 1000N. Determine minimum weight of the block B for maintaining the equilibrium of the system. Assume that the blocks are connected by an inextensible string passing over a frictionless pulley. Coefficient of friction μ_A between the block A and the plane is 0.25. Assume the same value for μ_B . (8M)

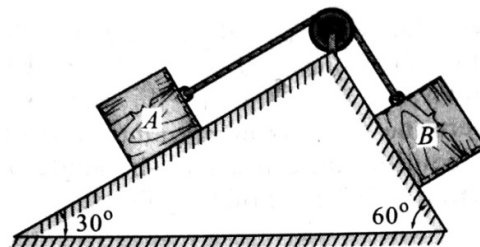

3. a) Explain the statement ``two equal and opposite parallel forces produces a couple``. (5M)

- b) Find the forces in all members of a truss as shown in figure which carries a horizontal load of 12kN at the point D and a vertical load of 18kN at the point C.

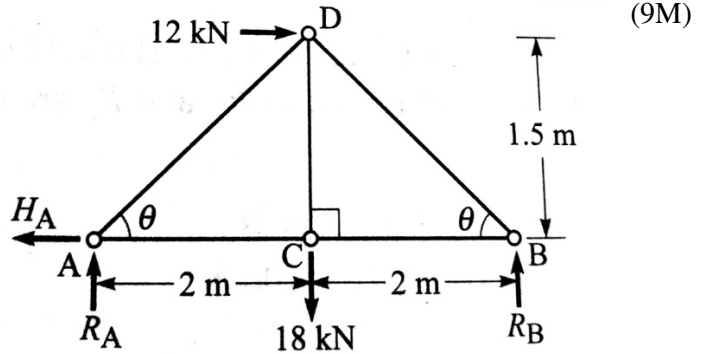

4. a) Locate the centroid of a semicircular disk of radius r. (6M)

- b) Find the centre of gravity of the I-section shown in figure? (8M)

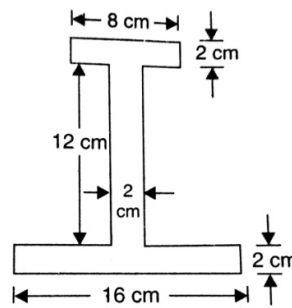

5. a) Determine the product of inertia I_{xy} of the area under the curve. (7M)

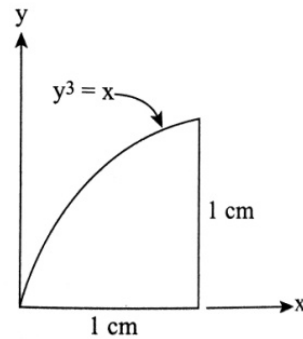

- b) Derive the mass moment of inertia of a right circular cone of base radius R, height H and mass M about its axis. (7M)

6. a) The driver of a car travelling at a constant speed of 10m/s sees the traffic signal ahead of him turning green, when he is at a distance of 200m from the signal. If the signal remains green for 15s, what should be his minimum acceleration in order to just cross the signal before the light turn's orange? Also, determine the speed with which he crosses the signal. (8M)

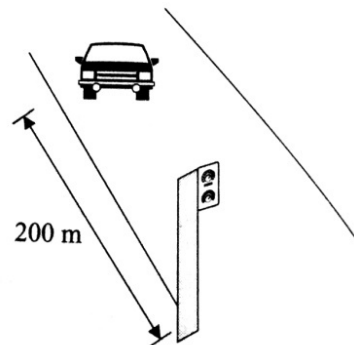

- b) An elevator together with the passengers weighing 2 tons is supported by a cable. Determine the acceleration of the lift when the tension in the cable is (i) 23 kN, when the lift is moving upwards and (ii) 18 kN, when it is moving upwards. (6M)

Code No: R161216

R16

SET - 4

7. A train of weight 18,365kg moves down at a uniform speed of 36kmph, along an incline of slope 1:83 and develops a power of 40kW as shown in figure. If the train is pulled up at the same speed, determine the power required to pull the train.

(14M)

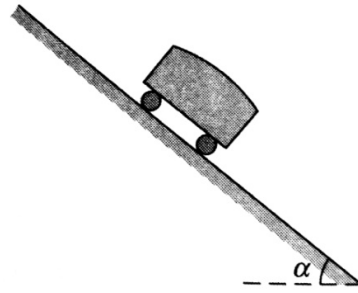

I B. Tech II Semester Regular/Supplementary Examinations, April/May - 2018
ENGINEERING MECHANICS
 (Com. to CSE, IT, AGE)

Time: 3 hours

Max. Marks: 70

- Note: 1. Question Paper consists of two parts (**Part-A** and **Part-B**)
 2. Answering the question in **Part-A** is Compulsory
 3. Answer any **FOUR** Questions from **Part-B**

PART -A

1. a) Define coefficient of friction. How is it related to angle of friction? (2M)
- b) State the necessary and sufficient conditions of equilibrium for a coplanar force system. (2M)
- c) Define the centre of gravity and centroid. (2M)
- d) Explain Polar moment of Inertia. (2M)
- e) Differentiate between kinematics and kinetics. (2M)
- f) Define Impulse and momentum. (2M)
- g) State the laws of friction. (2M)

PART -B

2. a) Explain how will you reduce the system of coplanar, non-concurrent forces to a force and a couple. (6M)
- b) A uniform ladder of weight 800N and of length 7 m rests on a horizontal ground and leans against a smooth vertical wall. The angle made by the ladder with the horizontal is 60° . When a man of weight 600N stands on the ladder at a distance 4m from the top of the ladder, the ladder is at the point of sliding. Determine the coefficient of friction between the ladder and the floor. (8M)
3. a) Three concurrent forces have magnitudes of 80 N, 120 N and 100 N respectively. Determine the angles among them that will produce a state of equilibrium. (6M)
- b) Determine the forces in all the members of a cantilever truss shown in the below figure. (8M)

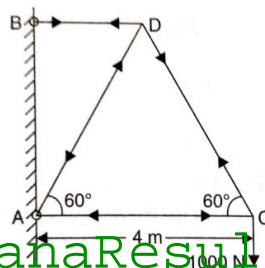

4. a) State and prove Pappus theorems of area and volume. (6M)

b) Locate the Center of gravity of the area as shown in figure with respect to coordinate axes. All dimensions are in mm. (8M)

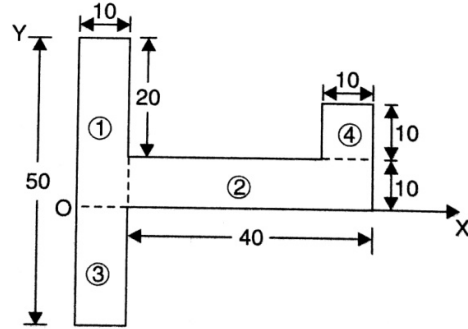

5. a) State and prove transfer formula for product of inertia. (6M)

b) Find the mass moment of inertia of an aluminum pipe of 120mm outer diameter and 90mm inner diameter and 2.5m height about its longitudinal axis. (density, $\rho=2560 \text{ kg/m}^3$). (8M)

6. a) A stone, dropped from a certain height, can reach the ground in 5s. It is stopped after 3 seconds of its fall and then allowed to fall again. Find the time taken by the stone to reach the ground for the remaining distance. (6M)

b) A launcher fires a missile with a velocity of 60m/s at an angle with the horizontal. If the missile lands 323m away at the same level, determine the angle of projection. Also find the corresponding time of flight and the maximum height attained by the missile. (8M)

7. A car weighing 15 kN is travelling down a 12° inclined road at a speed of 4 m/s, as shown in the figure. To avoid an accident, the driver suddenly applies full brakes causing wheels to lock. Determine how far the tyres skid on the road, if the coefficient of kinetic friction between the tyres and the road is 0.6 (14M)

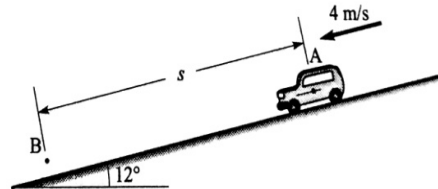

I B. Tech II Semester Regular/Supplementary Examinations, April/May - 2018
ENGINEERING MECHANICS
 (Com. to CSE, IT, AGE)

Time: 3 hours

Max. Marks: 70

- Note: 1. Question Paper consists of two parts (**Part-A** and **Part-B**)
 2. Answering the question in **Part-A** is Compulsory
 3. Answer any **FOUR** Questions from **Part-B**

PART -A

1. a) "Friction is independent of the area of contact between the two surfaces." Explain. (2M)
- b) Two forces are acting on a body and the body is in equilibrium. What conditions should be fulfilled by these two forces? (2M)
- c) State Pappus theorems. (2M)
- d) Explain area moment of inertia. (2M)
- e) When do we call a motion as rigid-body motion? (2M)
- f) State the principle of impulse-momentum. (2M)
- g) Write the equilibrium equations for a concurrent force system in space. (2M)

PART -B

2. a) What do you understand by the term 'Couple'? Discuss the characteristics of a couple. (6M)
- b) A pull of 60 N inclined at 25° to the horizontal plane, is required just to move a body placed on a rough horizontal plane. But the push required to move the body is 75N. If the push is inclined at 25° to the horizontal, find the weight of the body and coefficient of friction. (8M)

3. a) A 10 m boom supports a load of 600 kg, as shown in the figure. The cable BC is horizontal and 10 m long. Determine the forces in the boom and the cable. (8M)

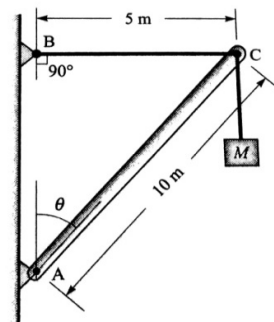

- b) Discuss the assumptions made in the analysis of simple truss. (6M)

4. a) Discuss the procedure to find the location of the centre of gravity of a composite body. (6M)

- b) For the I-section shown in figure, find the moment of inertia about the centroidal axis X-X perpendicular to the web. (8M)

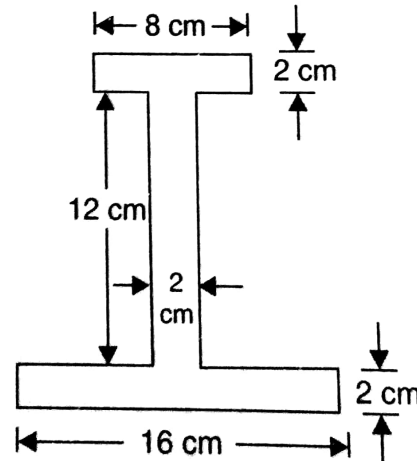

5. a) Find moment of inertia values of circle of radius 25mm about its centroidal XX and YY axes. (6M)

- b) Find the moment of inertia of an aluminum pipe of 150mm outer diameter and 120mm inner diameter and 3.5m height about its longitudinal axis YY. (density, $\rho=2560 \text{ kg/m}^3$). (8M)

6. a) An elevator is moving upwards with a constant speed of 10m/s. If a man standing inside the elevator drops a coin from a height of 2.45m, find the time taken by the coin to reach the floor of the elevator. ($g=9.8\text{m/s}^2$). (6M)

- b) A motor cyclist wants to jump over a ditch as shown in figure. Find the necessary minimum velocity at A and also find the inclination and the magnitude of velocity of motor cycle just after clearing the ditch. (8M)

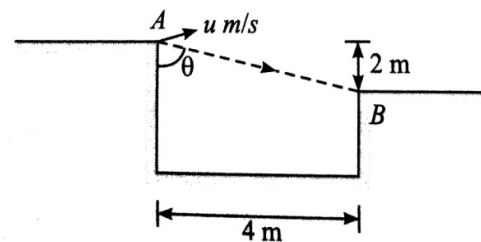

7. Three bodies – a sphere, a solid cylinder and a ring – each having same mass and radius are released from rest on a plane inclined at an angle θ as shown in figure. Determine the velocity of each body after it has rolled down (without slipping) the inclined plane through a distance s , and hence find the ratio of the three velocities. (14M)

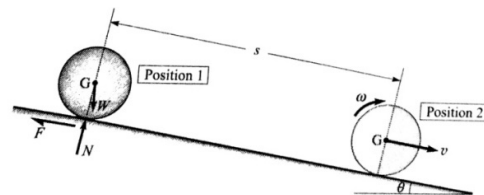

I B. Tech II Semester Regular/Supplementary Examinations, April/May - 2018**ENGINEERING MECHANICS**

(Com. to CSE, IT, AGE)

Time: 3 hours

Max. Marks: 70

- Note: 1. Question Paper consists of two parts (**Part-A** and **Part-B**)
 2. Answering the question in **Part-A** is Compulsory
 3. Answer any **FOUR** Questions from **Part-B**

PART -A

1. a) Define: (i) Cone of friction; (ii) Limiting friction. (2M)
- b) What are the conditions of equilibrium of a system of coplanar non-parallel, non-concurrent forces? (2M)
- c) What are the conditions under which the centre of gravity of a body becomes the same as its centroid? (2M)
- d) What is the significance of polar moment of inertia? (2M)
- e) State the assumptions made while studying projectile motion. (2M)
- f) State the work-energy equation for translation. (2M)
- g) Explain the statement, "Two equal and opposite parallel forces produces a couple". (2M)

PART -B

2. a) Explain the procedure to find the resultant of parallel forces. (6M)
- b) Three collinear horizontal forces of magnitude 300N, 100N and 250N are acting on rigid body. Determine the resultant of the forces when (i) All the forces are acting in the same direction; (ii) the force 100N acts in the opposite direction. (8M)
3. a) On a ladder supported at A and B, as shown in the figure, a vertical load W can have any position as defined by the distance a from the bottom. Neglecting friction, determine the magnitude of the reaction at B. Neglect the weight of the ladder. (8M)
- b) How will you prove that a body will not be in equilibrium when the body is subjected to two forces which are equal and opposite but are parallel? (6M)

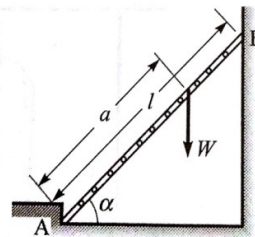

4. a) Determine the area generated by rotating a line of length l about x-axis from a distance r using Pappus theorem. (6M)

- b) For the T-section shown in figure, determine the moment of inertia of the section about the horizontal and vertical axes, passing through the centre of gravity of the section. (8M)

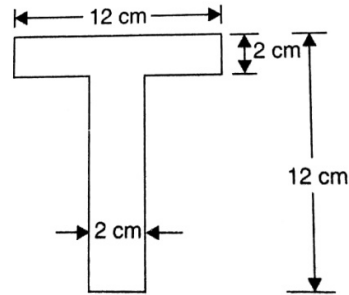

5. a) State and prove the parallel-axis theorem. (6M)

- b) Determine moment of inertia of a steel sphere 150mm diameter with respect to centre of gravity axes. Given density of steel as 7830 kg/m^3 . (8M)

6. a) Two bodies start moving in the same straight line at the same instant of time from the same origin. The first body moves with a constant velocity of 40 m/s , and the second starts from rest with constant acceleration of 4 m/s^2 . Find the time elapses before the second catches the first body. Also, find the greatest distance between them prior to it and the time at which this occurs. (7M)

- b) A particle undergoing central force motion has a tangential velocity of 20 m/s while at a distance of 300 m from the central point. Using the fact that the areal velocity of the particle must be constant, find its tangential velocity when it is 400 m away from central point. (7M)

7. Find the work done in moving a 20 kg wheel by 2 m up in an inclined plane with an angle of inclination equal to 30° with coefficient of friction 0.25 , if a force of 400 N is applied at the center of the wheel as shown in the figure. What will be the angular velocity of the wheel after the wheel has travelled 4 m up the plane? Take radius of the wheel to be 0.1 m . (14M)

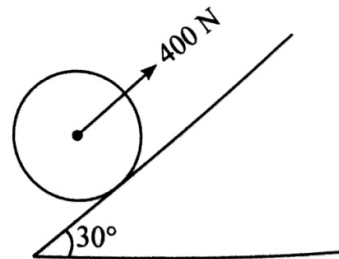

I B. Tech II Semester Regular/Supplementary Examinations, April/May - 2018

ENGINEERING MECHANICS

(Com. to CSE, IT, AGE)

Time: 3 hours

Max. Marks: 70

- Note: 1. Question Paper consists of two parts (**Part-A** and **Part-B**)
 2. Answering the question in **Part-A** is Compulsory
 3. Answer any **FOUR** Questions from **Part-B**

PART -A

1. a) Explain the phenomenon of friction by taking an example of a block placed on a rough surface. (2M)
- b) A number of forces are acting on a body. What are the conditions of equilibrium, so that the body is in equilibrium? (2M)
- c) What is the importance of axis of symmetry in determining the centre of gravity? (2M)
- d) What is the physical significance of moment of inertia? (2M)
- e) What do you understand by central force motion? (2M)
- f) Write the work-energy equation in case of fixed axis rotation. (2M)
- g) State D'Alembert's principle. (2M)

PART -B

2. a) Show that the algebraic sum of the resolved parts of a number of forces in a given direction is equal to the resolved part of their resultant in the same direction. (6M)

- b) Determine the resultant of the force system shown in the figure. Assume that the coordinates of different points are in meters. (8M)

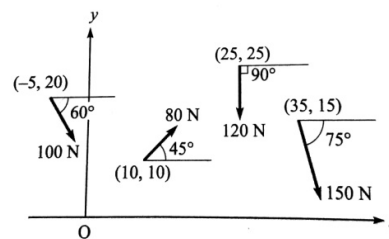

3. a) State and prove Lami's theorem. (6M)

- b) Find the forces in all the members of the truss given in the below figure. (8M)

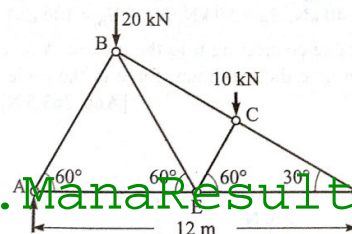

4. a) Determine the volume generated by rotating a semi-circular area of radius 'r' about a non-intersecting axis using Pappus theorem. (6M)

- b) Find the centre of gravity of the L-section shown in figure. (8M)

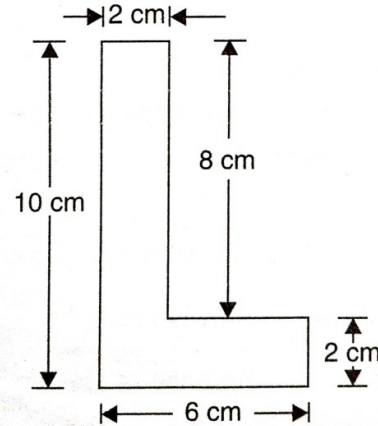

5. a) An isosceles triangle section ABC has a base of 100mm and 60mm height. Determine the moment of inertia of triangle about the centroid and about base. (6M)

- b) Determine moment of inertia of a cylinder shaft of 120mm diameter and 1.75m height about the centre of gravity XX, YY, ZZ axes. (density, $\rho = 8000 \text{ kg/m}^3$). (8M)

6. a) A vehicle running at 36km/h on a straight road accelerates uniformly to 72km/h over a distance of 200m. Determine the acceleration and time taken. How much distance will be covered by the vehicle in the 5th second? (6M)

- b) A solid cylinder weighing 1300N is acted upon by a force 'P' horizontally as shown in figure. Determine the maximum value of 'P' for which there will be rolling without slipping. (coefficient of friction, $\mu = 0.2$). (8M)

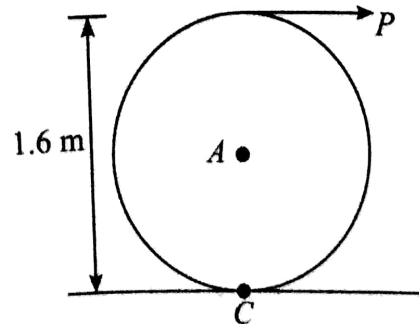

7. A bullet of 25 g mass is fired with a speed of 400 m/s. What is its kinetic energy? (14M)
If the bullet can penetrate 20 cm in a block of wood, what is the average resistance of the wood? If the bullet were fired into a similar block of 10 cm thick wood, what would be the exit speed?